



IBS Catalogue For Precast Concrete Building System Revision 2017



Copyright

Published in 2017 by
LEMBAGA PEMBANGUNAN INDUSTRI
PEMBINAAN MALAYSIA
Pusat IBS, Galeri Komponen IBS
Lot 8, Jalan Chan Sow Lin
55200 Kuala Lumpur
MALAYSIA

IBS CATALOGUE FOR PRECAST CONCRETE BUILDING SYSTEM REVISION 2017
CIDB Malaysia

Copyright © 2017 by Construction Industry Development Board Malaysia (CIDB)
ISBN 978-967-0997-09-4

All Rights Reserved. No part of this catalogue may be reproduced, stored and transmitted in any form, or by any means without prior written permission from CIDB Malaysia.

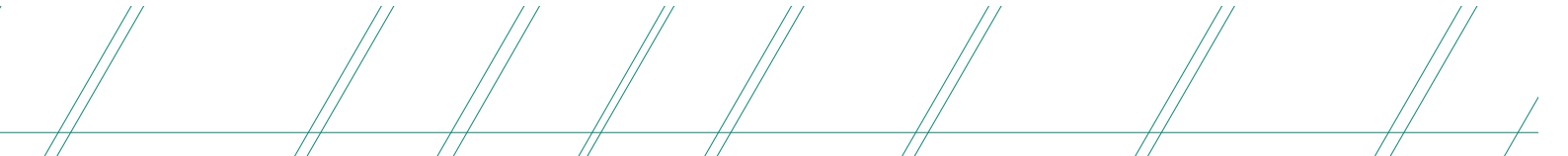

CONTENT

Preface	i
Acknowledgement	ii
List of Figures	iii
Preliminaries	1
Term of Reference	2
Scope of the Document	2
Main Objectives	2
Definitions and Notations	2
Safety and Health	3
Disclaimer	4
Part 1: Information on Precast Concrete Components	5
1.1 Introduction	6
1.2 Structural Elements	6
1.2.1 Precast Concrete Beam	7
1.2.2 Precast Concrete Column	8
1.2.3 Precast Concrete Load-Bearing Wall Panel	9
1.2.4 Precast Concrete Floor Slab	10
1.3 Non-Structural Elements	12
1.3.1 Precast Concrete Non-Load Bearing Wall	12
1.3.2 Precast Concrete Staircase	12
1.4 Connections	14
1.4.1 Column to Base Connection	15
1.4.1.1 Grouted sleeve connection	15
1.4.1.2 Pocket foundation connection	15
1.4.1.3 Steel base plate connection	16
1.4.2 Column to Column Connection	17
1.4.3 Beam to Column Connection	17
1.4.3.1 Visible connection	19
1.4.3.2 Hidden connection	19
1.4.4 Beam to Beam Connection	21
1.4.5 Slab to Beam Connection	21
1.4.6 Slab to Slab Connection	22
1.4.7 Slab to Wall Connection	22
1.4.8 Wall to Wall Connection	23
1.4.8.1 Horizontal joint	24
1.4.8.2 Vertical joint	25

1.5	Other Design Considerations	26
1.5.1	Structural Stability	26
1.5.2	Structural Integrity	26
1.5.3	Floor Diaphragm	27
1.5.4	Fire Rating	28
1.5.5	Mechanical and Electrical Services	28
	1.5.5.1 Embedded services	29
	1.5.5.2 Exposed services	29
1.5.6	Site Management for Precast Concrete Component	29
Part 2 : Selection of Precast Concrete Components		31
2.1	Selection of Precast Concrete Components	32
2.2	Structural Section Properties	32
2.3	Component Coding	32
2.4	Metric System	32
2.5	Flow Diagram	33
2.6	Step in Designing and Selecting a Component	34
	- Example 1: Simply Supported Precast Concrete Beam	35
	- Example 2: Precast Concrete Column	36
	- Example 3: Continuously Supported Precast Concrete Half Slab	38
	- Example 4: Continuously Supported Precast Concrete Prestressed Plank	39
	- Example 5: Precast Concrete Load Bearing Wall	40
	- Example 6: Precast Concrete Staircase	41
Part 3 : User Manual for Components Selections		43
3.1	Index of Tables for Precast Concrete Components	44
	- Precast Beam - Beam Rectangular (Simply Supported Beam)	47
	- Precast Beam - Beam Rectangular (Continuous Beam)	63
	- Precast Beam - Inverted T Beam (Continuous Beam)	81
	- Precast Beam - Edge Beam (Continuous Beam)	89
	- Precast Square Column	97
	- Precast Rectangular Column	109
	- Precast Half Slab - (Continuous Supported)	117
	- Precast Hollow Core Slab	123
	- Precast Prestressed Plank	127
	- Precast Wall (Load Bearing)	133
	- Precast Wall (Non-Load Bearing)	143
	- Precast Staircase	151
	- Precast Corbel Connection	161
	- Precast Column Nib Connection	167
	- Precast Half Joint Connection	171
	- Wet Joint Connections	175
References		181



Preface

The Industrialised Building System (IBS) is aimed to increase the productivity of the construction industry by accelerating the adoption of mechanisation and modern practices of construction. The implementation of IBS has been a productive transformation for the construction industry and it is growing rapidly. Hence, the availability of comprehensive information in the form of standard catalogue for key IBS components is vital for industry players.

This document “IBS CATALOGUE FOR PRECAST CONCRETE BUILDING SYSTEM (REVISION 2017)” produced by CIDB will be the basic reference for the design, detailing and manufacturing IBS component. This Catalogue will act as reference, information and guidance to engineers, architects, consultants, IBS manufacturers and contractors enabling them and their organisations to comply with the relevant and current documentation that accompanies the design and manufacture of IBS component.

CIDB wish to express their gratitude to Jabatan Kerja Raya Malaysia, IBS Manufacturers and all industry players who involved in the development of this Catalogue. This Catalogue will be a beneficial reference for industry players to increase the adoption of IBS. This is aligned with the government’s vision to enhance the productivity and economic growth of Malaysian construction industry.

IBS Centre, Construction Technology Division,
Construction Industry Development Board Malaysia
(CIDB)

Acknowledgement

A vote of thanks to the chairpersons and members of the organization bodies for their cooperation in compiling this IBS CATALOGUE FOR PRECAST CONCRETE BUILDING SYSTEM REVISION 2017.

Associated Concrete Products (M) Sdn. Bhd.	JCEC Concrete Sdn. Bhd.
BA Urus Bina (M) Sdn. Bhd.	Jeks Precast Sdn. Bhd.
Baktian Sdn. Bhd.	Joe Green Precast Sdn. Bhd.
BAP Concrete Sdn. Bhd.	Kencana Precast Concrete Sdn. Bhd.
BDC Concrete Sdn. Bhd.	KINU Enterprise Sdn. Bhd.
Binaan Desjaya Sdn. Bhd.	LAT Evergreen Sdn. Bhd.
Creative Precast Products Sdn. Bhd.	LSK Precast Sdn. Bhd.
Eastern Pretech (Malaysia) Sdn. Bhd.	NS Prefab Consultancy
Hume Concrete Sdn. Bhd.	Setia Precast Sdn. Bhd.
HC Precast System Sdn. Bhd.	Teraju Precast Services Sdn. Bhd.
IHS Precast Sdn. Bhd.	Yang Sulong (M) Sdn. Bhd.

CREAM Representatives

The main Secretariat from Construction Research Institute of Malaysia (CREAM):

Ir. Dr. Zuhairi Abd. Hamid
 Maria Zura Mohd. Zain
 Ahmad Hazim Abdul Rahim

Nurulhuda Mat Kilau
 Rohani Mokhtar
 Wan Norhasiah Wan Bidin

CIDB Representatives

Preparation of this catalogue is under supervision of the following CIDB's representatives:

Datuk Ir. Elias Ismail
 Ir. Noraini Bahri
 Ahmad Farrin Mokhtar
 Mohd Idrus Din

Mohamad Razi Ahmad Suhaimi
 Mohd Rizal Norman
 Ahmad Nazrol Ahmad Kamal
 Rozainah Ibrahim

JKR Representatives

Preparation of this catalogue is under supervision of the following JKR's representatives:

Kamaluddin Hj. Abdul Rashid
 Ir. Noreha Nordin
 Tengku Normardziah Tuan Mahmood

Ir. Zul Amri Abu Bakar
 Fernandez Au
 Nor Elina Naha

List of Figures

	Page
Figure 1: Precast concrete component in skeletal frame structure.	6
Figure 2: Internal beam (Inverted T beam) (Elliott, 2002)	7
Figure 3: External/ edge beam (Elliott, 2002)	7
Figure 4: Lifting precast concrete column component for erection and installation (courtesy to IBS Centre)	8
Figure 5: Two-storey precast concrete column (courtesy to IBS Centre)	9
Figure 6: Quarters building using load bearing wall system (courtesy to IBS Centre)	10
Figure 7: Precast concrete half slabs	11
Figure 8: Precast concrete hollow core slab	11
Figure 9: Prestressed precast concrete plank	11
Figure 10: Precast non-load bearing wall	12
Figure 11: Precast staircase component (flight, landing and mid-landing slab)	13
Figure 12: Types of connection in precast concrete structure	14
Figure 13: Grouted sleeve connection	15
Figure 14: Pocket foundation connection	16
Figure 15: Steel base plate connection	16
Figure 16: Typical column to column connection using grouted sleeve	17
Figure 17: Typical beam to column connection using corbel	18
Figure 18: Beam to column connection using grouted sleeve connection (Elliott, 2002)	19
Figure 19: Beam to column connection using welded plate (Elliott, 2002)	20
Figure 20: Beam to column connection using cleat connector (Elliott, 2002)	20
Figure 21: Beam to column connection using billet (Elliott, 2002)	20
Figure 22: Beam to beam connection using nib at the primary beam	21
Figure 23: Slab to beam connection with topping	21
Figure 24: Slab to slab connection on hollow core slab	22
Figure 25: Slab to slab connection on precast plank concrete	22
Figure 26: Slab to wall connection	23
Figure 27: Typical wall to wall connection	23
Figure 28: Horizontal wall to wall connection using reinforced in-situ joints (Elliott & Jolly, 2013)	24
Figure 29: Horizontal wall to wall connection using welded joint (Elliott & Jolly, 2013)	24

Figure 30:	Vertical wall to wall connection	25
Figure 31:	Virendeel girder	28
Figure 32:	Deep horizontal beam	28
Figure 33:	Flow diagram for designing and selecting suitable precast concrete components	33
Figure 34:	Na for inverted T beam	83
Figure 35:	Na for edge beam	91
Figure 36:	Examples of permitted sizes and locations of openings in precast hollow core	125
Figure 37(a):	Light duty fastening-light hangers using drill in anchor bolt	126
Figure 37(b):	Medium duty fastening-medium capacity hangers using special anchor fixed into the slab	126
Figure 37(c):	Heavy duty fastening-heavy duty hangers are fixed through slab and supported from top slab	126



PRELIMINARIES

Terms of Reference

The Construction Industry Development Board of Malaysia (CIDB) has developed this catalogue as the basic reference for designing, detailing, scheduling, manufacturing and member capacities of precast concrete components, according to British Standard BS 8110:1997.

This catalogue is published as a reference for contractors, manufacturing engineers, planners, architects, developers and other industry players to a guide them in designing precast concrete components.

Another purpose for this catalogue is to expedite the construction period, as the required components would be readily available in most precast concrete manufacturing factories. This process meets the Open System Concept while reducing component cost.

Scope of the Document

The current catalogue contains useful descriptions of precast components, the details of precast component and member capacities. Although it only summarises commonly used components, the details and information provided are sufficient, useful and applicable to assist the users.

This catalogue consists of three main parts. Part 1 contains all the information on the frame system of various precast concrete components, connections and other design considerations involved in the precast building system. Part 2 presents a guide for users in designing and selecting suitable precast components, along with other technical details. Examples on how to use and apply the information in this catalogue are also included in this part. Finally, Part 3 details the common standard sizes of precast concrete components produced by local manufactures. Product specification and drawing details have been included for each precast component.

Main Objectives

This catalogue aims to provide designers and quantity surveyors (QS) key information and references, including the description, sizing and detailing of precast concrete components.

The objectives are outlined as follows:

- i. To assist the architect as guide in preparing architectural drawing.
- ii. To assist the engineer in producing the tender drawing during the designing process.
- iii. To assist the quantity surveyor in providing the tender document during the procurement process.
- iv. To assist the manufacturer/supplier in producing shop drawing.

Definitions and Notations

The definitions applicable for this catalogue are as follows:

‘Precast Components’ are defined as structural precast components and are divided into seven main categories, namely beam, column, half slab, hollow core slab, prestressed planks, staircase and wall (load-bearing and non-load-bearing wall).

‘Competent Person’ is defined as any appointed Professional Engineer with Practising Certificate registered under subsection 10(D) of the Registration of Engineers (Amendment) Act 2015 from corporate bodies or consultant firm to provide professional services.

'Manufacturer' is defined as any person, firm or company under a contract with the Client to perform any work or supply goods in connection with the work or both, including a sub-contractor.

'Competent Installer' is defined as a person who is expert in at least one precast component installation and certified by CIDB.

'User' is defined as any person (engineer, quantity surveyor, architect, manufacturer and installer), firm or company who would use this catalogue.

Safety and Health

All relevant parties are responsible for ensuring that safety and health within the manufacturing plant and construction site conform with legislative requirements, approved standards, codes of practice, guidelines, specifications and contractual requirements. They shall also cover all practices during construction work, particularly those covered under Occupational Safety and Health Act, 1994, Factories and Machinery Act, 1967 and regulations made under these acts, such as Factories and Machinery (Building Operations and Works of Engineering Construction) (Safety) Regulations, 1986 and Factories and Machinery (Safety, Health and Welfare) Regulations, 1970. For purposes of terms and references, the following Acts, Regulations and OHS management system standards shall take precedence: Occupational Safety and Health Act, 1994 (Act 514) and Regulations, Factories and Machinery Act, 1967 (Act 139) and Regulations and Rules, OHSAS 18001: 2007, MS 1722: 2005 and ILO OHS MS: 2001.

Disclaimer

The information contained in this catalogue is for information, assist and guidance purposes only. CIDB makes no representations or warranties of merchantability or fitness for any particular purpose. Substantial effort has been made to ensure that all data and information in this publication are accurate. All and any information provided is for guidance purposes only, and data must be interpreted at the user's own engineering judgement as CIDB accepts no responsibility for using provisions of such data.

The engineering data provided are not intended in any way as engineering advice or services, or as a solicitation for any engineering product or service. Any results from the use of these data may not applicable with regard to individual circumstances, and cannot be reliable for anything, including, but not limited to, engineering designs or decisions. These engineering data are in no way a replacement for a thorough engineering review or design. A professional engineer, licensed in the appropriate field, should always conduct a formal evaluation under the circumstances.

Users are encouraged to offer comments and suggestions to CIDB for the improvement of the content within this catalogue. As a code of practice, this design guide focuses on guidance and recommendations. It should not be quoted as a specification, and particular care should be taken to ensure that claims of compliance are not misleading. This design guide does not purport to include all the necessary provisions of a contract. The users of this design guide shall be responsible for its correct application.



PART 1

INFORMATION ON PRECAST CONCRETE COMPONENTS

1.1 Introduction

A precast concrete framed building is one of the most popular industrialised building systems preferred by architects and engineers. This system involves the production of building components, as well as erection and assembly of these components, into a desired building structure by mechanical means, using as little in-situ construction as possible. The framed buildings consist of slab, beam, column, wall and staircase components that are fabricated or manufactured off-site. A systematic fabrication process is carried out to consistently produce similar components.

A precast concrete component is casted in a reusable mould, which is then cured under a controlled environment, transported to the site and placed at the required position. The quality of prefabricated concrete components is normally much better than cast in-situ concrete techniques given that the former is produced under controlled conditions.

1.2 Structural Elements

The common basic structural form for IBS is the skeletal frame system. A precast skeletal frame system is a structural system that consists of precast concrete slabs, beams, columns, walls and staircases that connect together between components as shown in **Figure 1**.

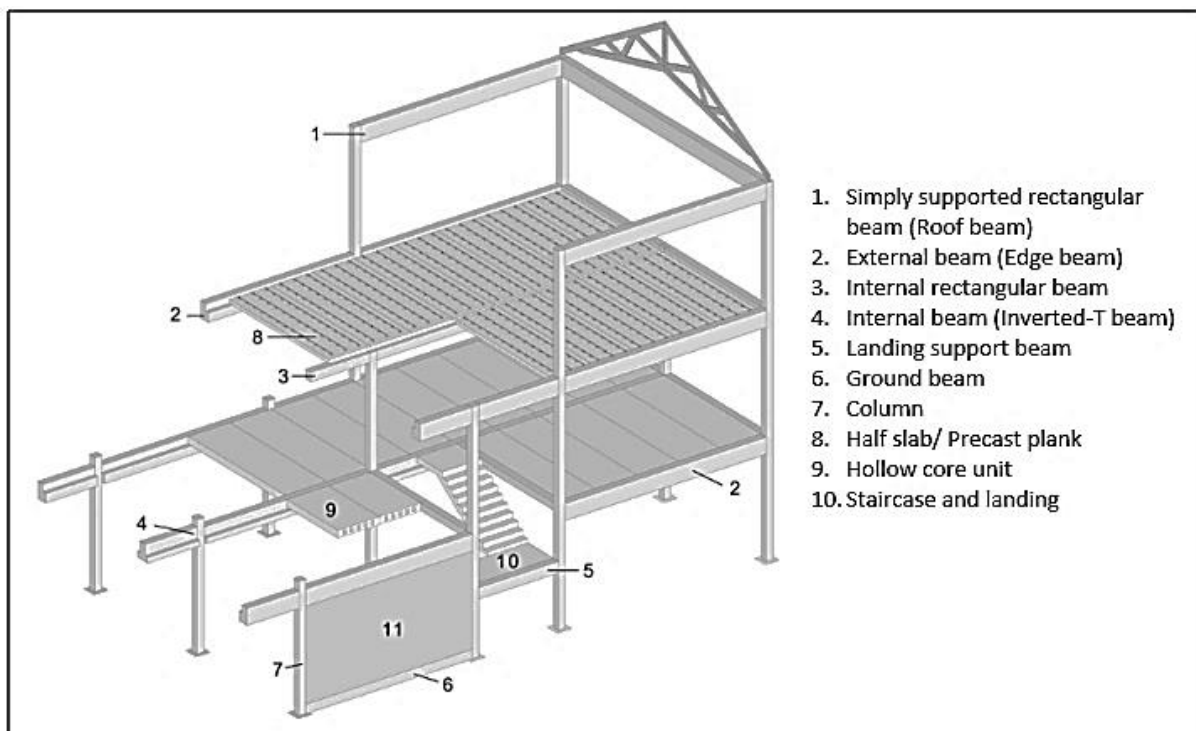

Figure 1. Precast concrete components in the skeletal frame structure.

1.2.1 Precast Concrete Beam

Beams, which are relatively small in prismatic sections but large in flexural and shear capacity, are the main horizontal load carrying members in skeletal structures. In a precast concrete structure, a precast concrete beam must be capable of supporting the self-weight of the floor slabs alone while resisting all possible load combinations during precast construction, such as torsion. During the temporary construction stage, the floor units are all positioned on one side of the beam. This must be considered in the design of the beam and in the end connections to the column.

Beams fall into two different categories, which are (1) internal and (2) external. Usually, internal beams are cross-sectionally symmetrical because the floor slabs are on both sides of the beam as shown in **Figure 2**. Meanwhile, the external/edge beams are asymmetrically loaded. **Figure 3** shows the effect of torsion when floor slabs sit on the bearing.

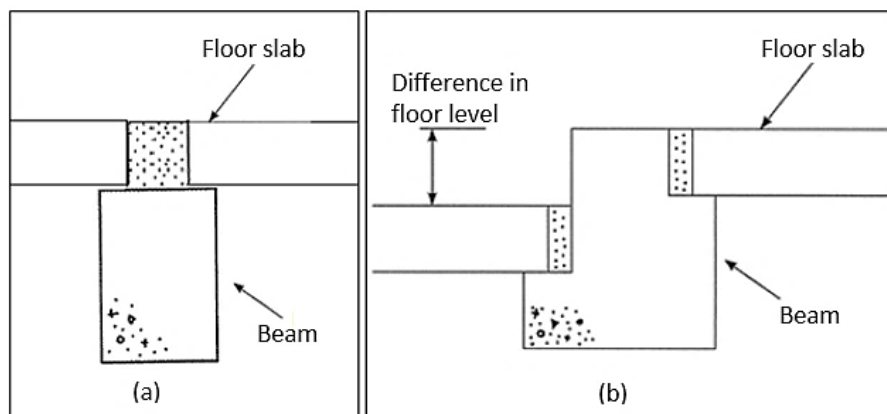

Figure 2. Internal beam (Inverted T beam) (Elliott, 2002)

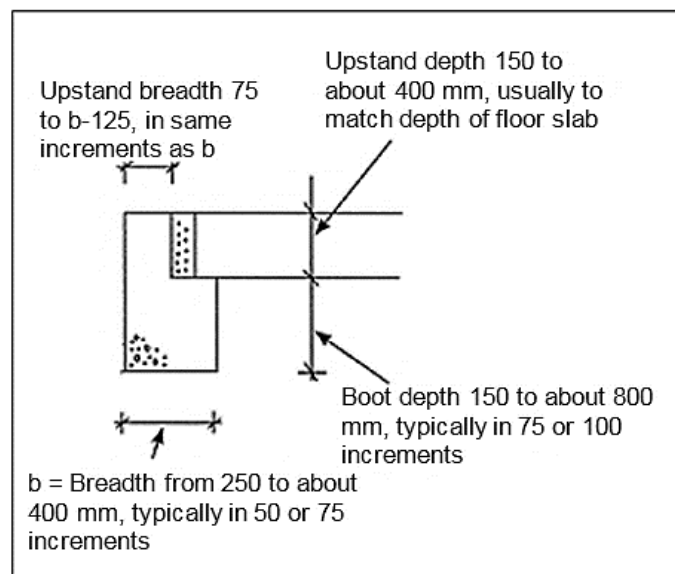

Figure 3. External/ edge beam (Elliott, 2002)

The types of beams selected do not depend on the function of the building. However, a flat or wide rectangular precast concrete beam is commonly used to support a long span hollow core slab because it provides sufficient bearing seating for the slab. Meanwhile, to increase the ceiling height, inverted T-beams and edge beams are used for internal and external beams, respectively. For a floor layout, a secondary beam is used to transfer the building load to the primary beam, which is connected to columns.

1.2.2 Precast Concrete Column

Precast concrete columns are the main vertical load carrying members in precast structures. The structural design of precast concrete columns is no different from ordinary reinforced concrete columns, except for the loading history that a precast concrete column experiences during manufacturing, transportation and erection as shown in **Figure 4**. The main design differences at the ultimate limit state are a function of the type of precast concrete structure and the type of connections than the resulting analysis of the column section.



Figure 4. Lifting a precast concrete column component for erection and installation

Square precast concrete columns with corbel structures are very common in this construction system. Corbels are used to provide support or bearing for beam ends to enable the immediate release of the beams from the crane after installation. Precast concrete columns can be fabricated up to four storeys high. However, for easy handling and transportation, one- and two-storey high columns are more preferred as illustrated in **Figure 5**.



Figure 5.Two-storey precast concrete column

1.2.3 Precast Concrete Load-Bearing Wall Panel

Precast concrete load-bearing wall panels have structural, aesthetic and functional features, which would result in the construction of an attractive building at a lower cost. These features allow the designer to express the structural system on the building façade and can become an important aspect in some designs. The load-bearing wall panels, which are connected at every floor level in multi-storey buildings, can be either one-storey or several storeys high, up to the maximum transportable length.

A precast concrete load-bearing wall can be a solid, sandwich or hollow panel that is suitably arranged to carry vertical and lateral loads. In practice, it is more cost efficient to take advantage of the inherent strength and rigidity of exterior wall panels, designing them to serve as the lateral load-resisting system when combined with the diaphragm action of the floor construction. Walls that resist and transfer horizontal loads (lateral forces) parallel to the plane of the wall, from the superstructure to the foundation, are referred to as shear walls. Thus, these walls serve as vertical cantilever beams. Usually, a structure will contain several walls that resist lateral forces in two orthogonal directions. The effectiveness of such a system largely depends on the panel-to-panel connections (Donaldson, 1991). **Figure 6** shows an example of a quarters building that was constructed using the load-bearing wall system.



Figure 6. Quarters building using a load-bearing wall system

1.2.4 Precast Concrete Floor Slab

During the construction of most types of buildings, precast concrete flooring offers a cost efficient and adaptable solution to ground and suspended floors. Moreover, it is widely used in commercial and domestic buildings because it offers both design and cost advantages over traditional methods, such as cast in-situ concrete, steel–concrete composite and timber floors. A wide range of flooring types is available to provide the most cost efficient solution for all loadings and spans. Given that floors give maximum structural performance with minimum weight, they may be used with or without structural toppings or non-structural finishes, such as tiles. The advantages of a precast concrete floor include off-site production of components with high strength and durability and the fast erection of long span floors at the site.

A floor slab may consist of many individual components, each designed to cater for specified loads, moments or others. It may also consist of a complete slab field wherein the loads are shared between the precast components per the structural response of each component. The components are joined together to form a diaphragm and are strengthened by a cast in-situ structural concrete topping with a minimum thickness of 50 mm, depending on the type of component and usage area (Elliott, 2002).

There are several types of flooring systems available in our country, which include:

- a) Precast concrete half slab (**Figure 7**)
- b) Precast concrete hollow core slab (**Figure 8**)
- c) Precast concrete prestressed plank (**Figure 9**)



Figure 7. Precast concrete half slab



Figure 8. Precast concrete hollow core slab



Figure 9. Precast concrete prestressed plank

1.3 Non-Structural Elements

1.3.1 Precast Concrete Non-Load Bearing Wall

Precast concrete non-load-bearing walls are not subjected to any load from the floor and roof. These walls may be made of hollow blocks, plaster boards, concrete or others, and are suitable for most types of buildings. They can be used for homes, townhouses, condominiums, apartments, hotels, schools and others. The wall panels are designed considering the structural requirements for strength, safety, sound and thermal insulation and fire resistance. Openings for doors and windows are casted into the walls at the manufacturing plant. Utility facilities, such as electrical and telecommunication conduits or boxes, are flush-mounted and casted into the panels at specified locations. As part of their normal practices, carpenters, electricians and plumbers are required to make some slight adjustments to fix the utility fittings accordingly.

A precast concrete wall can be easily manufactured in a factory and transported to the site. Given its smooth surface on both sides, wall finishes, such as painting or other desired textured surfaces, are easily applied. Speedy construction and durability of finished structures are hallmarks of precast concrete wall panels as shown in **Figure 10**.



Figure 10. Precast non-load bearing wall

1.3.2 Precast Concrete Staircase

Stairs are a vital part for the evacuation of people in during fires and/or accidents. Staircases should be designed to remain intact, and the connections should be detailed in such a way that its stability is maintained, especially in cases of accidents. Precast concrete staircases can be fabricated either individually or as a complete unit, depending on the structural arrangement chosen (**Figure 11**). A simple support or a degree of continuity by projecting steel from the precast components can be used as the connection between the landing and the

staircase. The landings (or other supporting structures) support and anchor the precast staircase flight, with a continuity force equal to the self-weight of the flight. Meanwhile, the structure supports and anchors the landings, with a continuity force equal to the self-weight of the flights plus the landings (Fib, 2012).

During construction, the precast concrete staircase can simply be dropped into the building by a crane, even after most of the work has been completed in the rest of the building. For example, a tower crane housed in the stairwell can be lifted out after the crane has been used to construct all the main elements of the building. A mobile crane can then be used to lift the stair units into place through the top of the staircase, which will have been left open at the roof level (Riley & Cotgrave, 2014).

A precast concrete staircase has the following advantages:

- i. Good quality control of the finished product
- ii. Rapid construction
- iii. Immediate access for following trades
- iv. Better space utilization, since formwork fabrication and storage will not be required
- v. No propping
- vi. Fire resistance of up to 4 hours
- vii. Ability to withstand exceedingly high imposed loads
- viii. Installation of the stairs at any time after the floors have been completed, fully utilising the stair shaft as a lifting or hoisting space if required
- ix. Hoisting, positioning and fixing can usually be carried out by semi-skilled labour.

Nevertheless, enough staircases using each mould must be needed to make casting cost-effective. Therefore, for a one-off two-storey building with only one staircase, using precast concrete would be inefficient, but for a six-storey building with two identical staircases in each floor, i.e. 12 staircases, precast stairs would be efficient.



Figure 11. Precast staircase component (flight, landing and mid-landing slab)

1.4 Connections

The most important aspect to consider in precast concrete structures is the design and construction of joints and connections. There are several different ways of achieving a satisfactory connection, such as bolting, welding or grouting. Beams and columns are connected to form an integrated frame system before the floor slabs are placed. Hence, structural connectors are required to connect all the structural components of beams, columns and slabs. The major structural connections include beam to column, column to column and column to base, and are either structurally pinned or rigid (**Figure 12**). The complete precast frame must be designed in compliance with the required strength, stiffness, ductility and reliability.

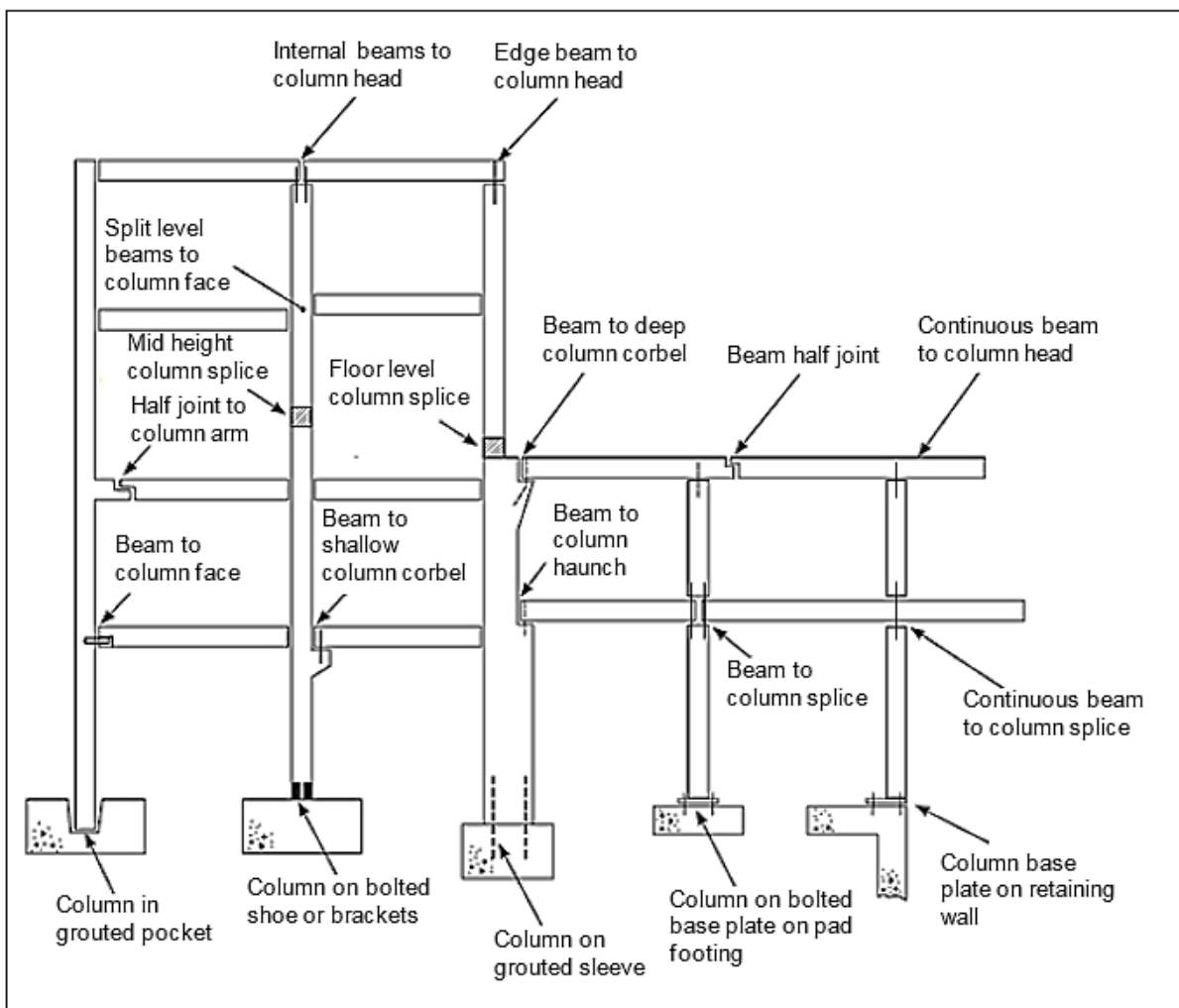

Figure 12. Types of connections in the precast concrete structure (Elliott, 2002).

1.4.1 Column to Base Connection

The typical and commonly used column to base connections are (a) grouted sleeve, (b) pocket foundation and (c) steel base plate. Although the base plate method is the most expensive among the three, it is more advantageous given that its column may be immediately stabilised and plumbed vertical by adjusting the level of the nuts to the holding down bolts. The two key approaches in designing the column base into the foundation include either pinned or moment resisting, depending on the overall stability requirements of the frame and the cost of the project (Elliott, 2002).

1.4.1.1 Grouted sleeve connection

The grouted sleeve connection is the most cost efficient and easily used column base connection. The precast concrete column is manufactured with corrugated sleeves. The projecting bars from the foundation are accurately placed into the sleeves in the precast column. Then, the corrugated sleeves are filled with expansive flowable non-shrink grout as shown in **Figure 13**. The column must remain propped until the grout has hardened and is usually removed after the first-floor beams and slabs have been placed.

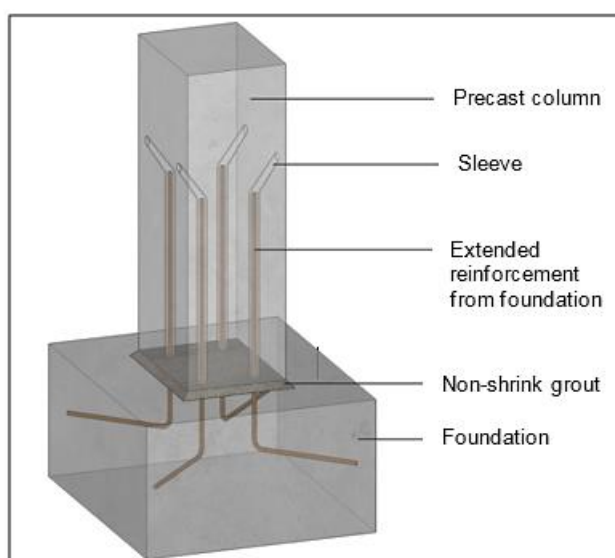

Figure 13. Grouted sleeve connection

1.4.1.2 Pocket foundation connection

The pocket foundation is the most cost efficient and easily constructed column base connection, especially for large concrete pad footings. The in-situ concrete foundation is cast using a tapered box shutter to form the pocket. The foundation may also be used to support precast ground beams. Subsequently, the gap between the pocket and the column is filled with non-shrink grout as the precast concrete column is inserted into pocket formed in the footing. The gap in between is then filled with non-shrink cement grout as shown in **Figure 14**.

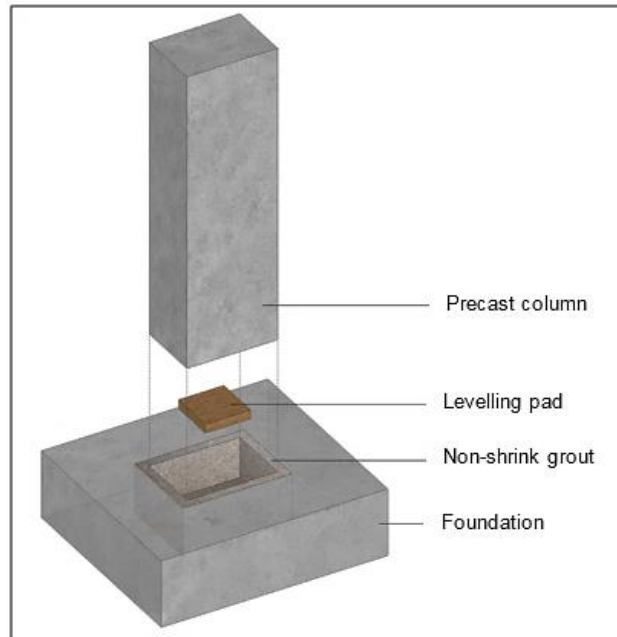

Figure 14. Pocket foundation connection

1.4.1.3 Steel base plate connection

The steel base plate type, which is larger than the column (**Figure 15 (a)**), is used when a moment connection is required. Usually, confinement reinforcement around the bolts is required, particularly when a narrow beam or wall is used and the steel is designed based on the principle of shear friction. Meanwhile, as shown in **Figure 15 (b)**, a column with a flush base plate is used as the pinned connection in the brace frame due to the limited moment capacity. The holding down bolt group is in line with the main column reinforcement. The gap between the plate and foundation in both types is filled with non-shrink cement grout.

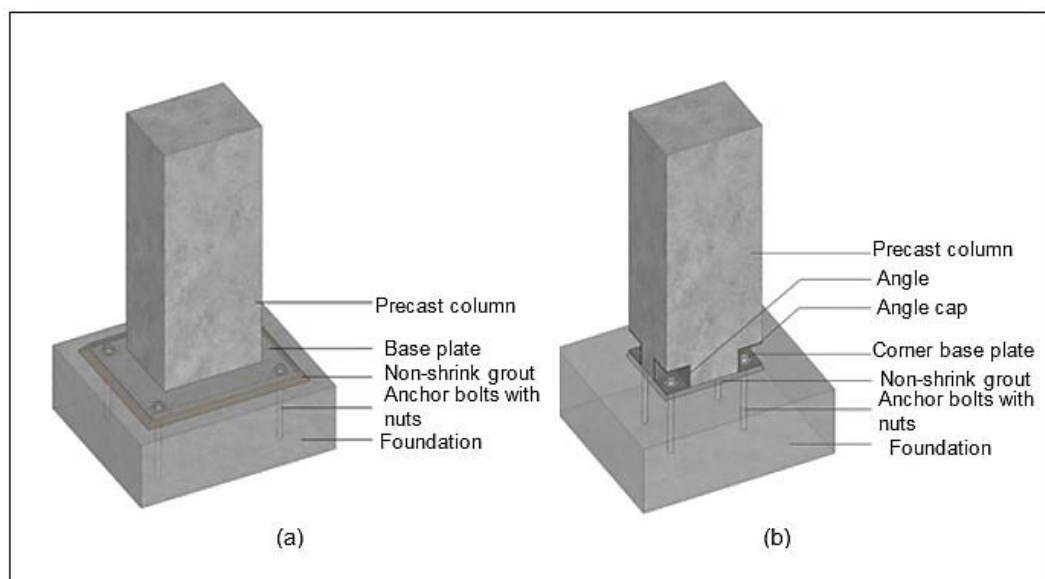

Figure 15. Steel base plate connection

1.4.2 Column to Column Connection

In all joint designs, the connection must be able to resist the applied structural forces. It should also be clearly determined whether the joint functions as a pinned or moment connection. **Figure 16** shows a typical column to column connection using a grouted sleeve joint. A moment resistance grouted joint is formed by casting a small quantity of in-situ grout around the projecting reinforcement. A full anchorage bond length is achieved by tying the bars together length-wise in grouted joints. However, the pressurised grout may be inserted to ensure that the in-situ infill grout fully bonds with the steel bars.

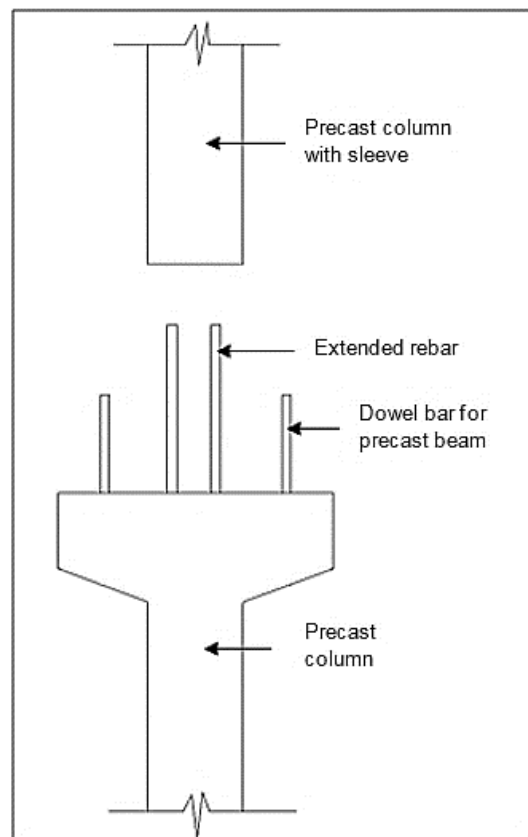

Figure 16. Typical column to column connection using a grouted sleeve

1.4.3 Beam to Column Connection

The beam to column connection is the most important part in the precast concrete structures. The simplest method of connecting the beam to the column is to place the beam on top of the column. However, for two or three-storey buildings, it is more appropriate to use a column with corbel or nib support (refer to **Figure 17**). Typically, a beam to column connection may comprise two or three beams. Hidden connectors are better than corbels in multi-beam connections due to difficulties in the casting process. There are few options for beam to column connectors, which have been divided into two categories, namely hidden and visible connections as described in the next section. The gap between precast components is filled using cement grout containing a proprietary expanding agent.

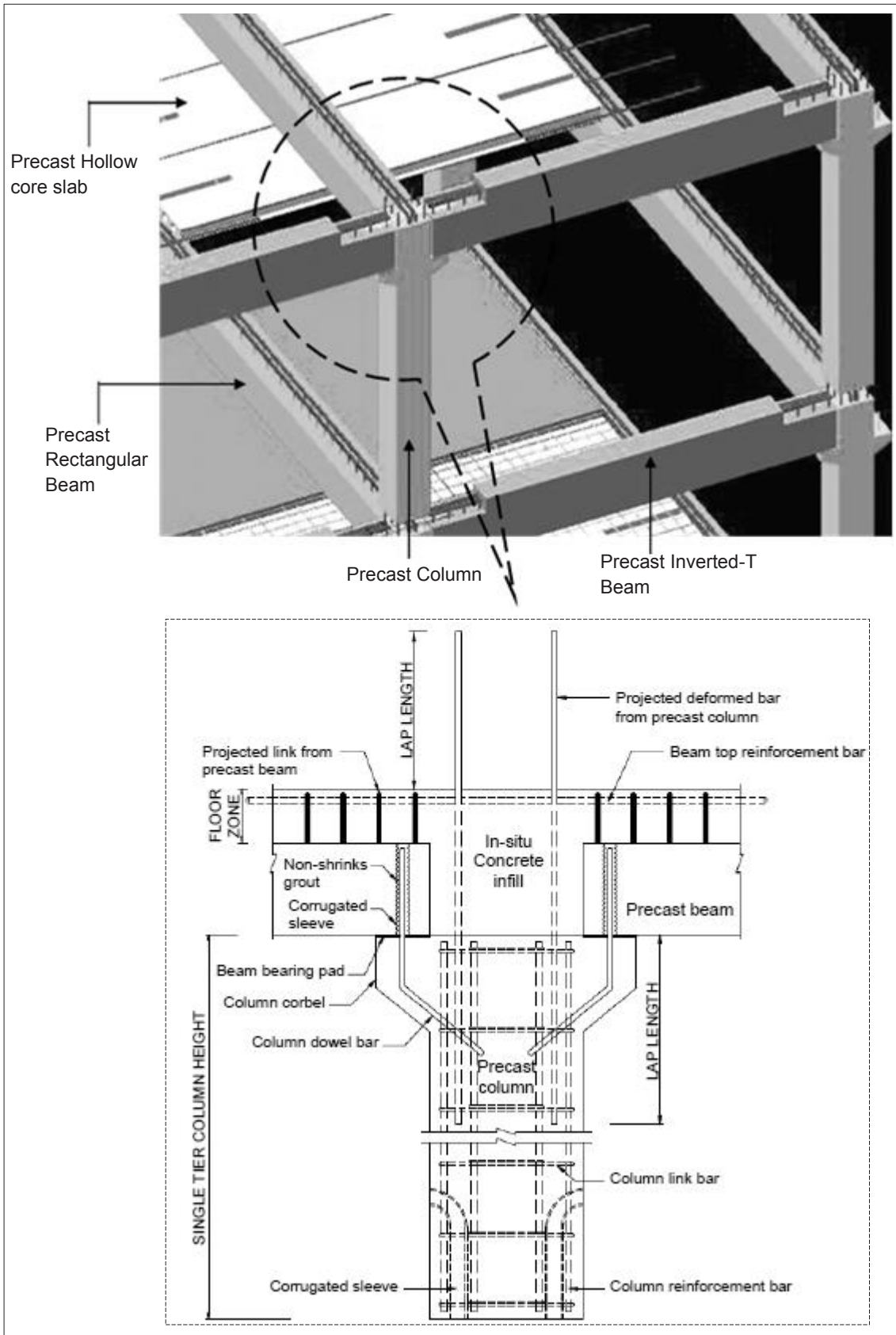

Figure 17. Typical beam to column connection using corbels

1.4.3.1 Visible connection

Figure 18 shows an example of a visible connection, which is a shallow corbel using a grouted sleeve connection. This corbel connection is designed as a simple support to carry large shear forces, V , at the end of the beam. In practice, corbel connections are used extensively in parking structures and when mostly heavy loads are to be transferred from beams to column.

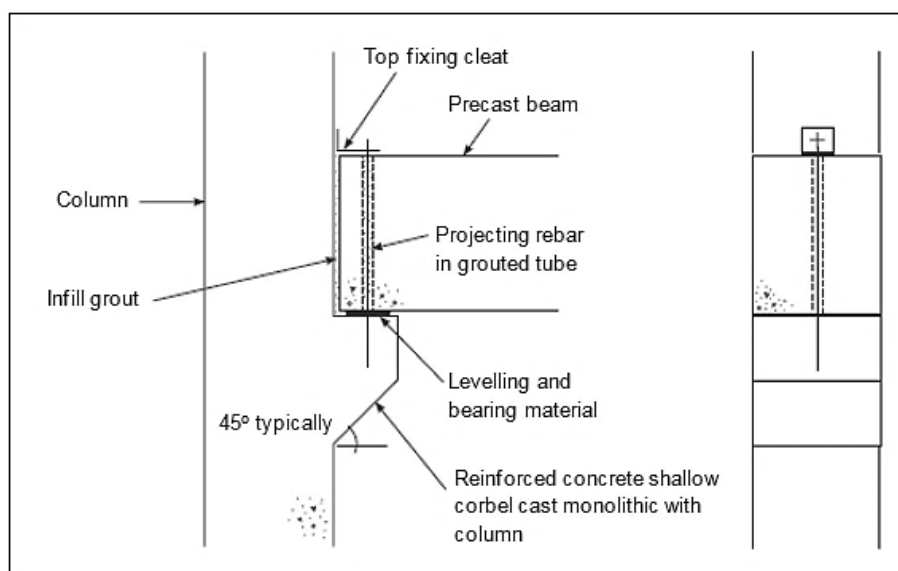

Figure 18. Beam to column connection using a grouted sleeve connection (Elliott, 2002)

1.4.3.2 Hidden connection

Several connectors exist as hidden connections to link the beam and column elements as shown in **Figure 19** to **Figure 21**. **Figure 19** shows the welded plate connector, where weld preparations have been made to the adjoining beam and column inserts. Meanwhile, **Figure 20** shows the cleat connector, which normally includes rolled structural tees, rolled angles, fabricated plate angles or box gussets that receive a bolted connection to both beam and column components. A rolled steel or plate fabricated H section in the column is presented in **Figure 20**, while the steel billet connector, also one of most commonly used connections, is illustrated in **Figure 21**. A mild steel threaded dowel is attached through the holes in the projecting billet to a bolted cleat.

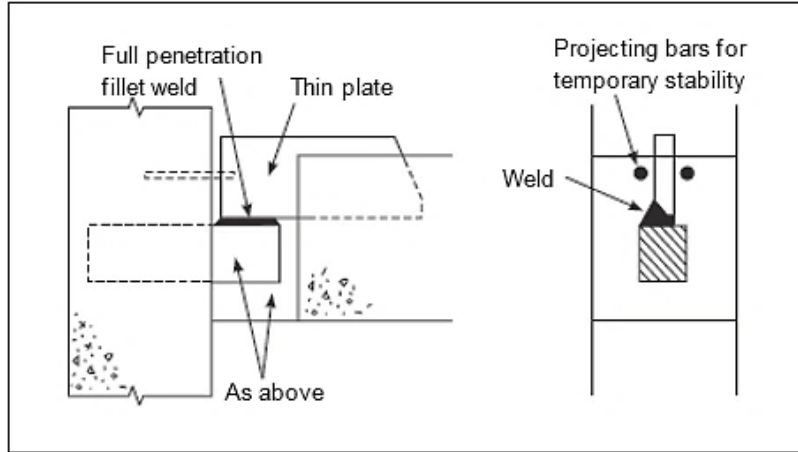

Figure 19. Beam to column connection using a welded plate (Elliott, 2002)

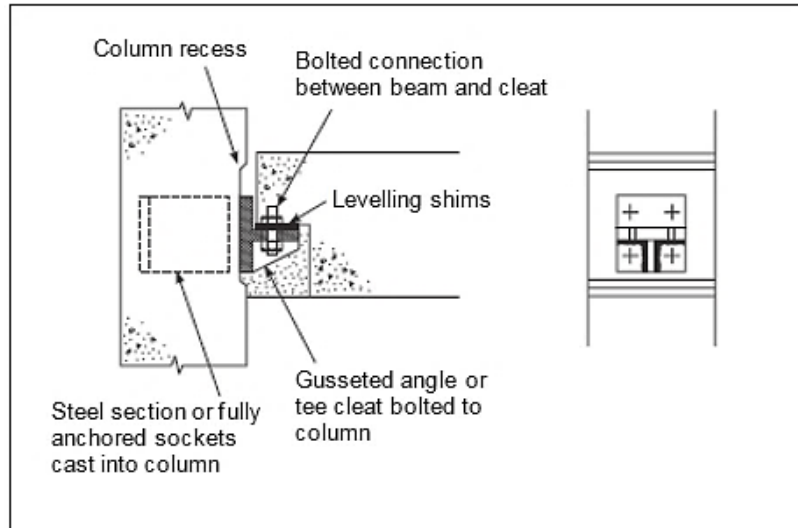

Figure 20. Beam to column connection using a cleat connector (Elliott, 2002)

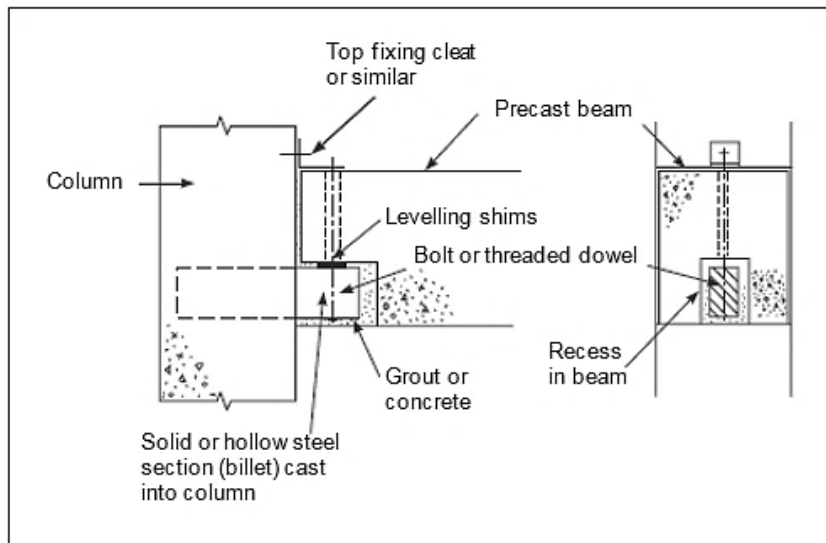

Figure 21. Beam to column connection using a billet (Elliott, 2002)

1.4.4 Beam to Beam Connection

Figure 22 illustrates a precast beam to beam connection using the nib at the primary beam connected by tie steel between the beams. These two precast components are connected using casting in-situ concrete.



Figure 22. Beam to beam connection using the nib at the primary beam

1.4.5 Slab to Beam Connection

Figure 23 presents an example of a slab to beam connection using a tie steel. The horizontal floor ties are evenly distributed using short length tie steels anchored by bonding into the open cores of the hollow core floor units. This connection relies on the pull-out force generated by the tie steel that is cast into the in-situ concreted hollow core. Adequate anchorage must be provided by the tie steel to lock into the bottom of the hollow core.

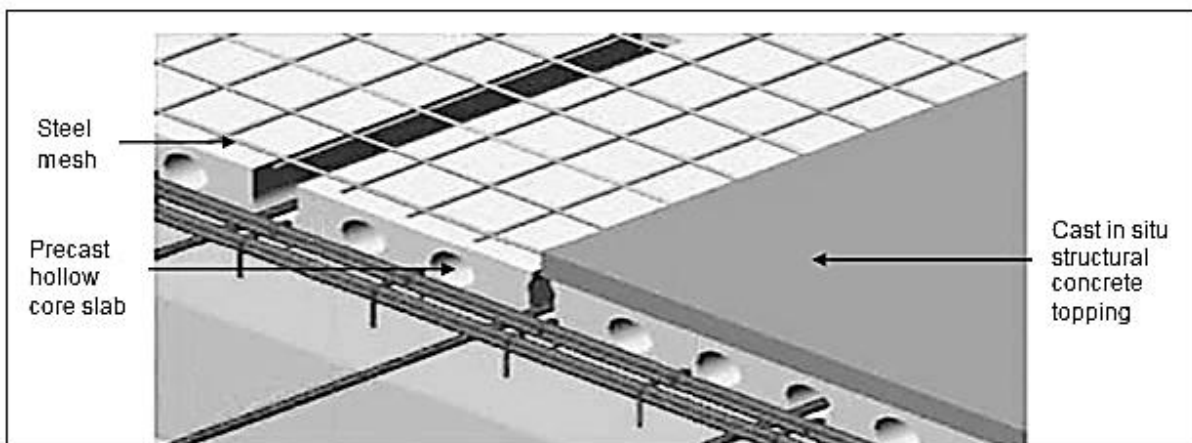

Figure 23. Slab to beam connection with topping

1.4.6 Slab to Slab Connection

Slab to slab connection is usually done through structural topping as shown in **Figure 24**. The common minimum thickness is 50–75 mm. Floor ties are used to provide continuity between floor slabs as illustrated in **Figure 25**. The best approach with regard to floor ties is to present a continuous ring of reinforcement around each floor slab bay bounded by beams.

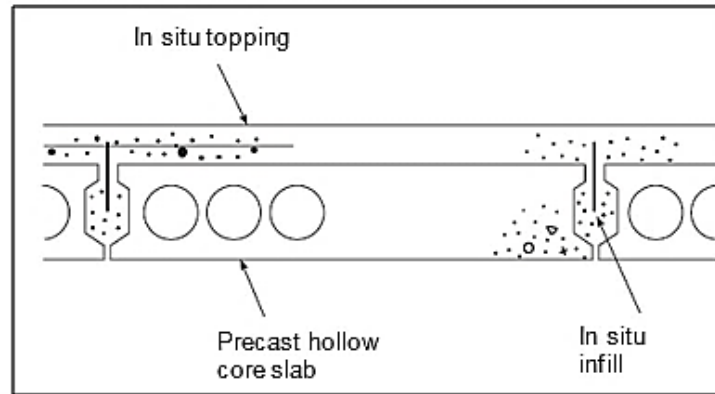

Figure 24. Slab to slab connection on a hollow core slab

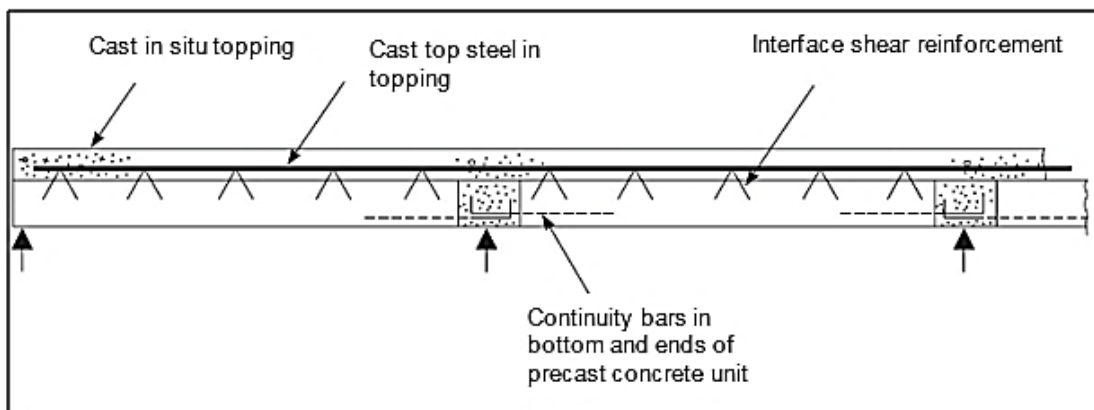

Figure 25. Slab to slab connection on a precast plank concrete

1.4.7 Slab to Wall Connection

The connection between the wall support and the floor requires careful detailing when the floor units are supported within the breadth of the walls and have several arrangements. The floor slab may be placed on the top of a panel, between two panels at an intermediate floor level, in a recess in the panel or supported on a rib of the panel. **Figure 26** shows an example of a precast floor placed between load-bearing walls at an intermediate floor level connection. Several hollow core units may require strengthening to prevent web buckling.

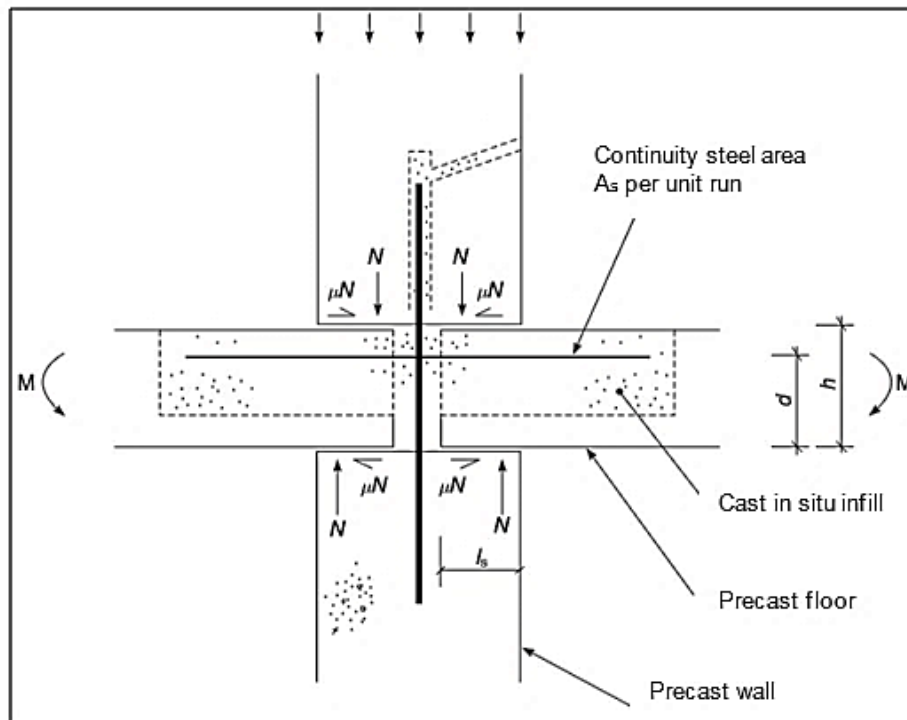

Figure 26. Slab to wall connection

1.4.8 Wall to Wall Connection

Figure 27 shows a typical precast wall to wall connection that can be achieved through horizontal or vertical joints. The vertical joint is subjected to forces resulting from the loads acting on the panels. Both joints can be grouted using high-strength or small-diameter aggregate concrete.

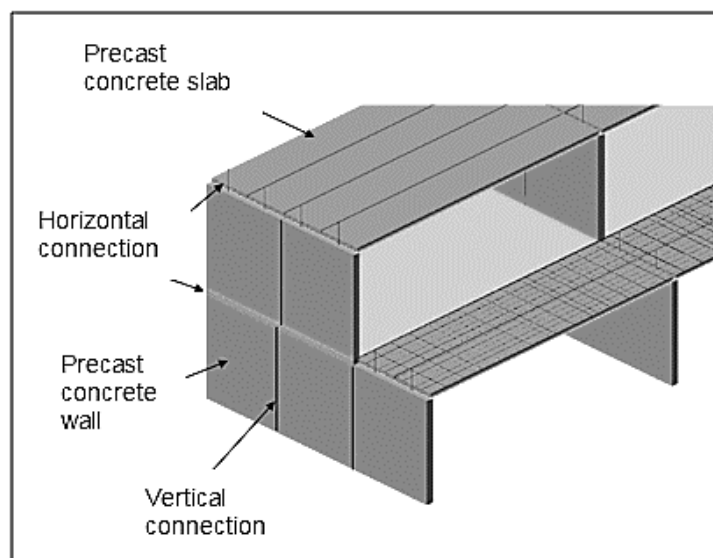

Figure 27. Typical wall to wall connection

1.4.8.1 Horizontal joint

Vertical reinforcement in precast walls is usually lapped at horizontal joints. For this purpose, proprietary grouted steel sleeve splices may be used. Alternatively, the lap can be formed by grouting a bar extending from one unit into the metal duct in the matching unit. **Figure 28** shows the extensive use of in-situ concrete and tie steel, while **Figure 29** shows a wall connection using welded joints.

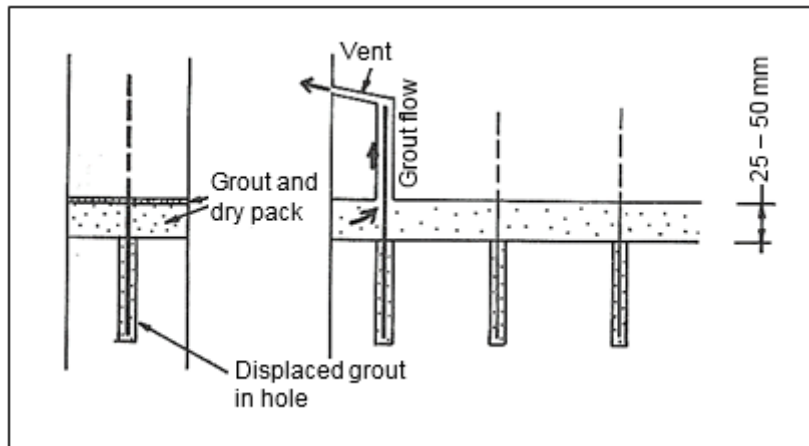

Figure 28. Horizontal wall to wall connection using reinforced in-situ joints (Elliott & Jolly, 2013)

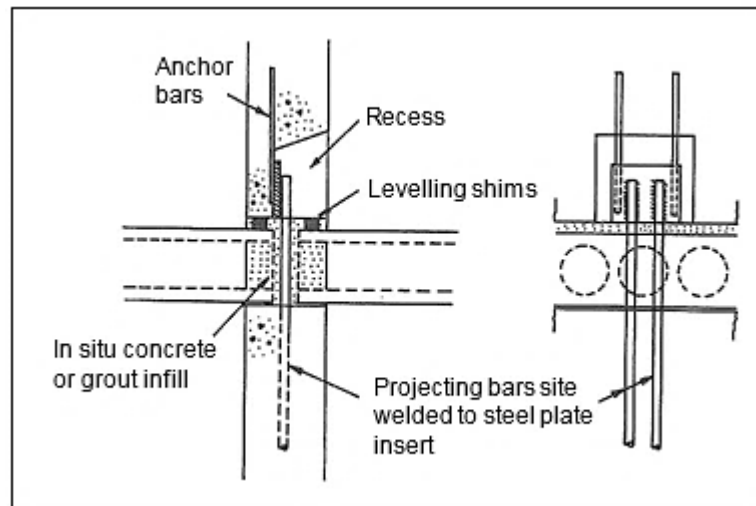

Figure 29. Horizontal wall to wall connection using welded joint (Elliott & Jolly, 2013)

1.4.8.2 Vertical joint

Vertical joints between precast wall panels are typically cast in-situ type joints. A horizontal reinforcing bar from a precast panel projects into the joint zone and is overlapped or welded with the horizontal reinforcing bar from an adjacent panel as shown in **Figure 30**. Alternatively, the two panels can also be joined together using embedded plates, bolts and welds and connecting plates.

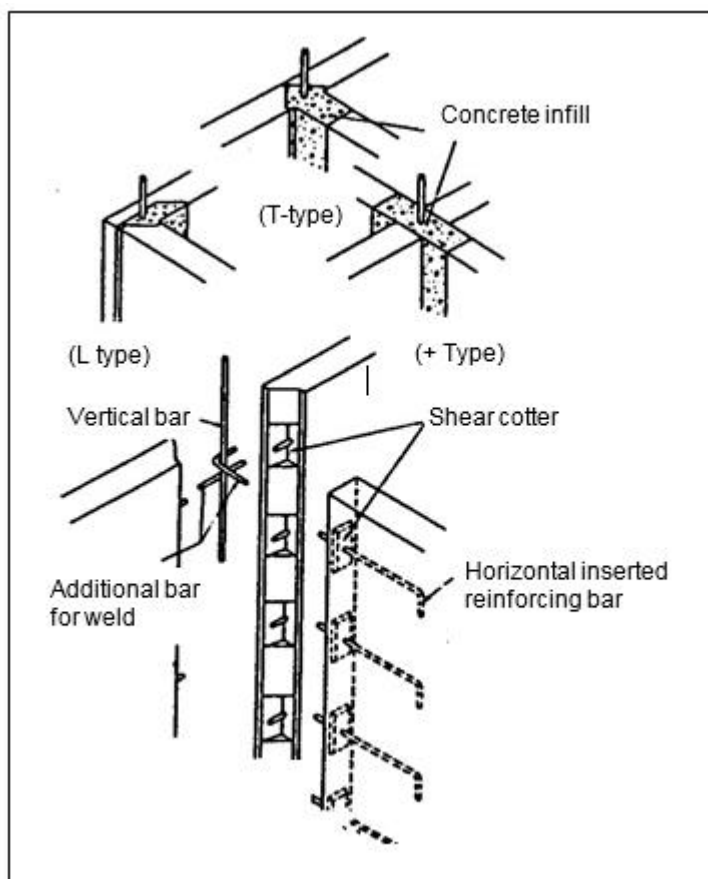

Figure 30. Vertical wall to wall connection

1.5 Other Design Considerations

1.5.1 Structural Stability

Structural stability in precast concrete construction is achieved when all connections are activated. Hence, stability and safety are important factors that need to be considered when designing the structure at all stages of construction.

A structure is designed to achieve overall stability, during and after construction. When erecting a structure, it is important to provide temporary supports and bracings to strengthen lateral stability. However, to design for horizontal stability, we need to ensure that all dead loads, imposed loads and wind forces are transferred to the foundation system.

An assessment of the safety of the structures, loss of stability and post-buckling behaviour is essential. For instance, the peripheral ties in the floor act as a tensile reinforcement allowing the floor diaphragm to resist the plane moments caused by horizontal wind forces. These forces may possibly lead to column misalignment, tilting of the building and other defects.

However, in compliance with project requirements related to architecture, structure and commerce, the overall stability, strength and reliability of a building need to be ensured by a competent person in accordance with the relevant code of practice. The above requirement also applies to precast concrete components specified in this catalogue.

1.5.2 Structural Integrity

Structural integrity is the ability of the structure to overcome local failure. Failures are initiated by accidental loads that have not considered in the design. These accidental loadings include errors in design or construction, local overloading, service system (gas) explosion, bomb explosion, vehicular and falling material impacts, intense localised fire, foundation settlement and seismic effects. All of these accidents can cause progressive collapse in precast structures.

To reduce or eliminate accidental loading risks, designing for accidental damage is introduced. Three alternative methods are used in designing for accidental damage and are presented as follows (Triakha and Ali, 2004):

Alternative methods	Description
Designing of key elements	Elements and connections vital to the ability of the entire structure to withstand an ultimate pressure of 34 kN/m ² (clauses 2.6.2 and 2.2 of Parts 2 and 1, respectively, BS 8110). This solution is impractical and uneconomic.
Designing of “bridging” elements	The intact elements that provide an alternative path after each vertical load-bearing element, except when the key element in each storey is considered lost in turn (clause 2.6.3, Part 2 and clauses 2.4.3.2 and 2.4.4.2, Part 1, BS 8110). This method is not cost efficient as most members have to be heavily reinforced.
Provision of structural ties	Formation of a 3-dimensional network of continuous and fully anchored tensile elements. This is the most adopted method of preventing progressive collapse.

1.5.3 Floor Diaphragm

The floor diaphragm is a horizontal system that transmits lateral forces to vertical-resisting elements. The floor needs to be designed as a diaphragm when the distance between the bracing elements is large enough to sustain the shear forces and bending moments. In precast concrete buildings, stability is achieved in two ways, which include (a) transmission of the horizontal wind loads to the shear walls or moment resisting frames in the floor and (b) transmission of the each flooring level’s horizontal reaction forces to the foundation via columns or bracing elements. The robustness and redundancy of a structure is highly dependent on the performance of the diaphragms. How the diaphragm behaves depends on the floor plan geometry, which could include (a) a Vierendeel girder as shown in **Figure 31** or (b) the more usual deep horizontal beam having a compression arch and tensile chord as shown in **Figure 32** (Elliott, 2002).

Aside from wind loading, the floor diaphragm may be subjected to additional horizontal forces brought by the lack of structure verticality, temperature and shrinkage effects and in-plane or catenary forces as consequence of abnormal loading or accidental damage. When the precast floor units are not capable of carrying horizontal forces in the floor diaphragm, the diaphragm forces must be transmitted by other means, which may include structural topping. In other words, the precast floors act as a permanent shuttering. The shear is carried entirely by the reinforced in-situ concrete topping (Elliott, 2002).

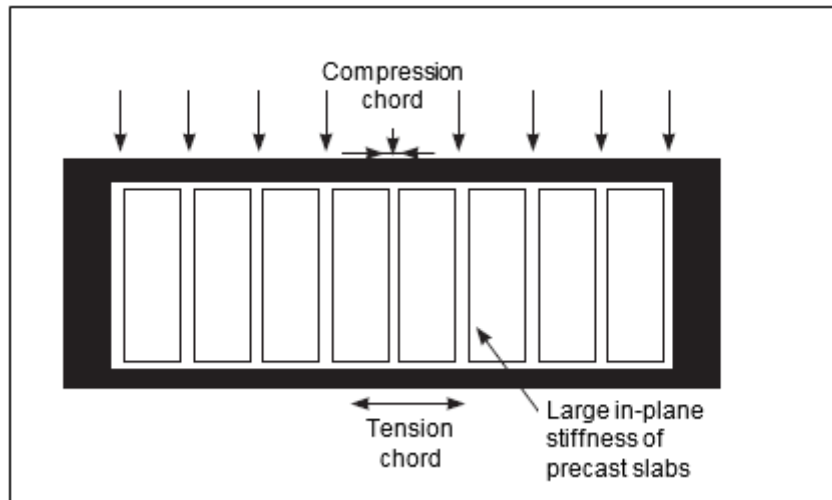

Figure 31. Vierendeel girder (Elliott, 2002)

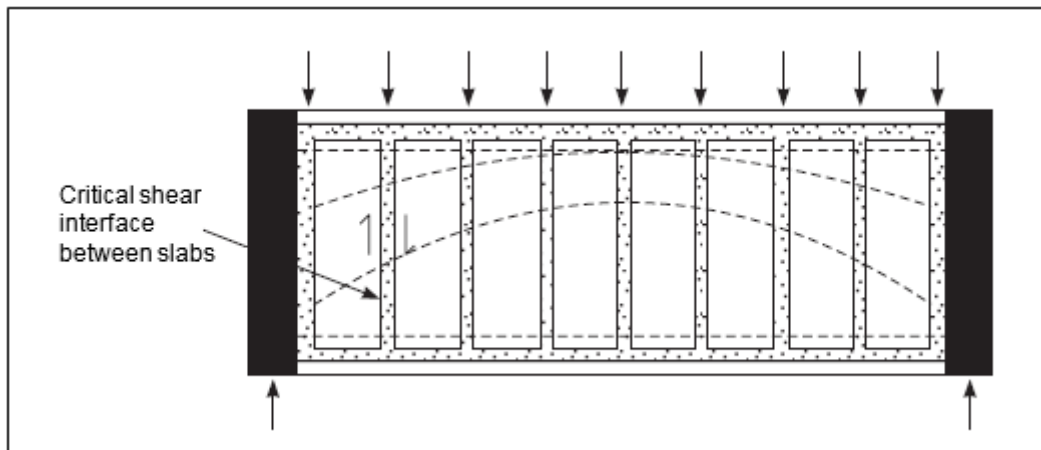

Figure 32. Deep horizontal beam (Elliott, 2002)

1.5.4 Fire Rating

The structural components must comply with fire rating requirements as specified in the relevant standard and local authority requirements.

1.5.5 Mechanical and Electrical Services

In the precast concrete construction system, pre-planning and pre-determining almost all mechanical and electrical (M&E) services inside individual precast panels is necessary. This requirement changes the standard working practice, which can be overwhelming for contractors who are not accustomed to it or lack the necessary resources. However, such pre-planning can prevent errors in M&E services, improve quality and reduce delays and costs. M&E services can either be embedded or exposed.

1.5.5.1 Embedded services

Mechanical and electrical services can be embedded in either the floor or wall slab. Horizontal services embeds relevant elements in either the floor slab topping or precast half slab, whereas vertical services embeds elements in the precast wall.

Embedded services should be pre-determined and pre-planned to coordinate the interfaces of all horizontal and vertical elements. This is to ensure that all services are accommodated and well organised without affecting the structural characteristics of the panels.

1.5.5.2 Exposed services

Another method of installing M&E services is through external trays known as exposed services. They are more advantageous given that they reduce pre-planning activities and are very flexible to any changes or additional M&E services.

Vertical service lines should be generally pre-planned and concealed within the walls. This is facilitated through the use of “pockets” or wide grooves in precast panels left for connections, such as power points, electrical wirings or piping for a fan coil unit. The positions of the connecting pockets would have to be predetermined. Fortunately, this is easier to accomplish in typical landed housing environments. The pockets would be grouted with appropriate material after the M&E connections are done at the site. The size of the pockets should be slightly larger to cater for site tolerance and ease of connection.

Horizontal service lines are installed on top of the precast floor slab at the site. These services would be later concealed in the concrete topping layer.

1.5.6 Site Management for Precast Concrete Component

The systematic production of precast components at the factory should also be efficiently managed at the construction site. This ensures the timely delivery of correct components without any defects in order to effectively accomplish the fabrication process. Transporting, handling, storing and installing of components should be managed efficiently and in accordance with practices given in the guidelines of the Construction Industry Standard, CIS 9:2008.







PART 2

SELECTION OF PRECAST CONCRETE COMPONENTS

2.1 Selection of Precast Components

Precast concrete components and their technical details are compiled and presented as a catalogue in Part 3. The said catalogue contains basic information for precast concrete components, such as section properties, capacities and detailing. Users may use this catalogue as a guide in choosing the appropriate size of precast concrete components at various span lengths and live loads.

This part serves as a guide for users in designing and selecting suitable precast concrete components available in the market. Components available and produced by local manufacturers are beams, columns, half slabs, hollow core slabs, prestressed walls and staircases. Examples on how to use and apply the information are illustrated in the catalogue. However, users still need refer to a competent person for other details, including production, handling, delivery, storage and fabrication of the precast concrete components as required. Moreover, typical examples of connections are provided to assist users in applying them. Other types of alternative connections have not been incorporated in this portion.

2.2 Structural Section Properties

This catalogue contains the common standard sizes of precast concrete components produced by local manufacturers. If other sizes unspecified in this catalogue are required, the user shall refer to a competent person for further advice.

2.3 Component Coding

This catalogue provides details and properties of structural precast concrete components, and identifies each component with a code. The coding system has units and abbreviations specifying a respective product, allowing users to browse through the names of the respective precast components. However, this catalogue will be updated accordingly from time to time.

2.4 Metric System

The metric system, known as the International System of Units (abbreviated as SI), is the system of measurement and dimension used for all plans, details and specifications in this catalogue.

2.5 Flow Diagram

A guideline for users in designing and selecting suitable precast concrete components is shown in the Flow Diagram (Figure 33).

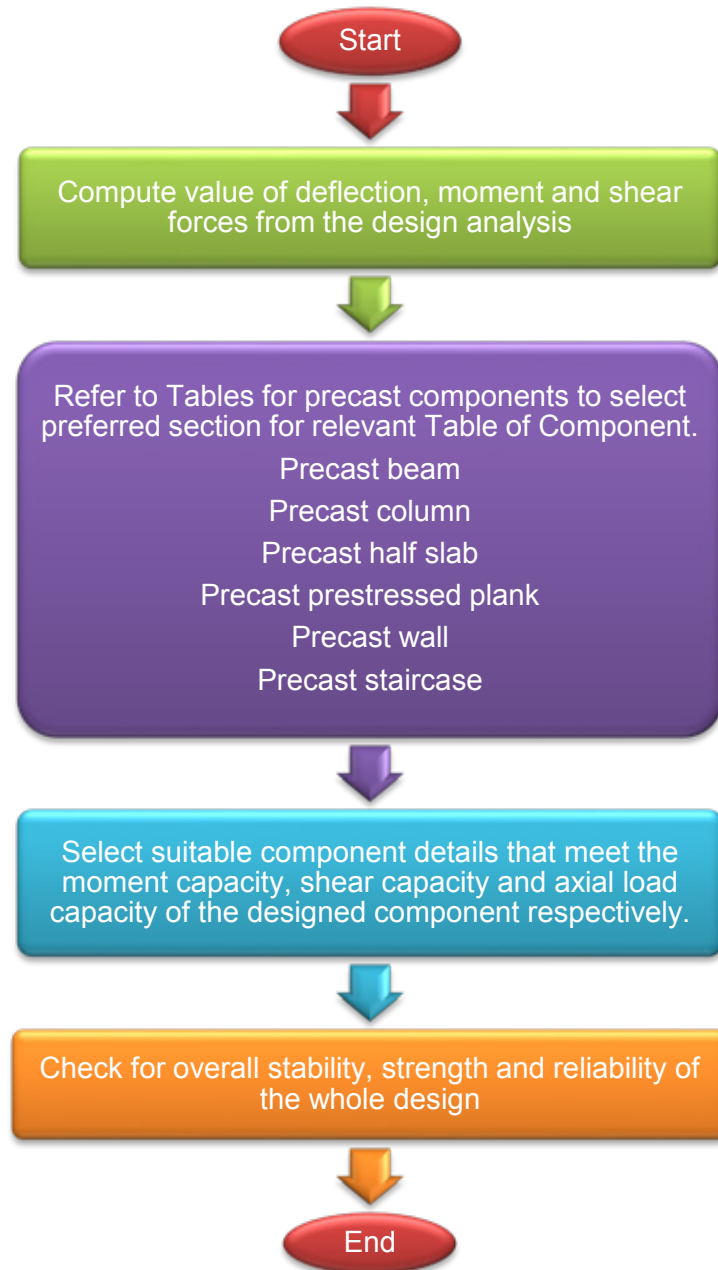

Figure 33: Flow diagram for designing and selecting suitable precast concrete components.

2.6 Steps in Designing and Selecting a Component

Detailed steps in designing and selecting the appropriate standard precast concrete components.

Step 1 : Analyse structural framing of the building to compute the required moment and shear

- i. Precast beam
 - Moment (kNm)
 - Shear (kN)
- ii. Precast column
 - Axial load (kN)
 - Moment (kNm)
- iii. Precast half slab
 - Moment (kNm/m width)
 - Shear (kN/m width)
- iv. Precast prestressed plank
 - Axial load (kN)
 - Moment (kNm)
- v. Precast wall
 - Axial load (kN)
 - Moment (kNm)

Step 2 : Selection of preferred section

Refer to Index of Tables for Precast Components at page 44 – page 46 to select preferred section for relevant Table of Components.

Step 3 : Table of Component

Select suitable component details that match the moment, shear and axial load capacities of the designed component from the Table of Components.

Examples on how to use the catalogue tables are given below.

Example 1: Simply Supported Precast Concrete Beam

To design a simply supported precast rectangular beam of 6.0 metre long with ultimate moment of 90.41 kNm and shear force of 60.27 kN.

Step 1: List out given data as follows: -

Installation stage design: -

During installation stage, perimeter beam is designed to support selfweight of beam only.

Final stage design: -

Ultimate moment, M_u	= 90.41 kNm
Shear force, V	= 60.27 kN
Length of simply supported beam	= 6 m
High Tensile reinforcement, f_y	= 460 N/mm ²
Mild steel, f_{yv}	= 250 N/mm ²
Compressive strength of concrete, f_{cu}	= 35 N/mm ²

Compressive strength of concrete during installation and final stage is 25 N/mm² and 35 N/mm² respectively.

Step 2: Selection of preferred section

Refer to Index of Tables for Precast Components on Page 44-Page 46 to search for relevant Table of Component required. Information required is shown in Table 4 on Page 57.

Step 3: Code of Component

Deduce maximum moment and maximum shear capacity from Table 4 on Page 57 and select Code of Component. Select suitable component details based on values greater than required. The Product Code BR-2055-L6 is then selected which contains following properties and conforms to given data as above.

Maximum moment, M_u	= 107 kNm
Maximum shear, V	= 71 kN
Size of beam	= 200 x 550 mm
Main reinforcement	= 2T20
Links	= R10-250 c/c

Example 2: Precast Concrete Column

To design 4.0 metre high a square precast concrete column, with 200 kN maximum axial load and 3.0 kNm maximum moment at installation stage. While at final stage, the maximum axial load and maximum moment of the column are 1800 kN and 60 kNm respectively.

Step 1: List out given data as follows: -

Installation stage design: -

Maximum axial load, N_i = 200 kN
 Maximum moment, M_{xi} or M_{yi} = 3 kNm

Final stage design: -

Maximum axial load, N_i = 1800 kN
 Maximum moment, M_{xf} or M_{yf} = 60 kNm
 High tensile reinforcement, f_y = 460 N/mm²
 Mild steel f_{yv} = 250 N/mm²
 Compressive strength of concrete, f_{cu} = 35 N/mm²

Compressive strength of concrete during installation and final stage is 25 N/mm² and 35 N/mm² respectively.

Step 2: Selection of preferred section

Refer to Index of Tables for Precast Components on Page 44-Page 46 to look for relevant Table of Component required. Information required is shown in Table 23 on Page 102.

Step 3: Code of Component

Deduce maximum axial load and maximum moment for both initial and final stage from Table 23 on Page 102 and select Code of Component. Select suitable component details based on values greater than required. The Product Code CS-3535-03 is then selected which contains following properties and conforms to given data as above.

Installation stage: -

Maximum axial load, N_i	= 300 kN
Maximum moment, M_{xi} or M_{yi}	= 12 kNm

Final stage: -

Maximum axial load, N_f	= 2200 kN
Maximum moment, M_{xf} or M_{yf}	= 65 kNm
Size of beam	= 350 x 350 mm
Main reinforcement	= 4T25
Links	= R10-300 c/c

Example 3: Continuously Supported Precast Concrete Half Slab

To design a continuously supported precast half slab with ultimate moment at mid span and support of 10.51 kNm/m width and a shear capacity of 17.52 kN/m width. The slab span is 4 metre, tensile strength of slab is $f_y = 460 \text{ N/mm}^2$ and compressive strength of slab is $f_{cu} = 35 \text{ N/mm}^2$.

Step 1: List out given data as follows: -

Ultimate moment at mid span and support, M_u	= 10.51 kNm/m width
Shear force, V	= 17.52 kN/m width
Slab span	= 4 m
High tensile reinforcement, f_y	= 460 N/mm ²
Compressive strength of slab, f_{cu}	= 35 N/mm ²

Step 2: Selection of preferred section

Refer to Index of Tables for Precast Components on Page 44-Page 46, to search for relevant Table of Component required. Information required is shown in Table 28 on Page 121.

Step 3 : Code of Component

Deduce maximum moment and maximum shear capacity from Table 28 on Page 121 and select Code of Component. Select suitable component details based on values greater than required. The Product Code HS65-150 is then selected which contains following properties and conforms to given data as above.

Ultimate moment at mid span and support, M_u	= 30 kNm/m width
Shear force, V	= 47 kN/m width
Slab span	= 4 m
Thickness of precast half slab, T	= 65 mm
Overall depth, D	= 150 mm
Main reinforcement	= T10-100 c/c

Example 4 : Continuously Supported Precast Concrete Prestressed Plank

To design a continuously supported precast concrete prestressed plank of 90 mm thick with superimposed dead load (SDL) of 1.7 kN/m^2 and live load of 3.0 kN/m^2 . The slab span is 4.5 metre. The compressive strength of precast prestressed slab is $f_{cu} = 50 \text{ N/mm}^2$ and topping is $f_{cu} = 35 \text{ N/mm}^2$.

Step 1 : List out given data as follows :-

Superimposed dead load, SDL	= 1.7 kN/m^2
Live load	= 3.0 kN/m^2
Slab span	= 4.5 m
Compressive strength of precast slab, f_{cu}	= 50 N/mm^2
Compressive strength of topping slab, f_{cu}	= 35 N/mm^2

Step 2 : Selection of preferred section

- Refer to Index of Tables for Precast Components on Page 44-Page 46, to search for relevant Table of Component required. Information required is shown in Table 30 on Page 131.

Step 3 : Code of Component

Gather dead load and live load from Table 30 on Page 131 and select Code of Component. Select suitable component details based on values required. The Product Code PSP90-165-04 then selected which contains following properties and conforms to given data as above.

Length of slab	= 4.5 m
Superimposed dead load, SDL	= 1.7 kN/m
Live load	= 3.0 kN/m
Thickness of precast half slab, T	= 90 mm
Overall depth, D	= 165 mm
Strand formation	= 6M (medium size of 12.9mm)

Example 5 : Precast Concrete Load Bearing Wall

To design for precast wall with thickness of 200 mm, ultimate axial load, N_w of 1500 kN/m and moment of 92 kNm/m. The compressive strength of precast concrete load bearing wall is $f_{cu} = 35 \text{ N/mm}^2$.

Step 1 : List out given data as follows :-

Wall Thickness	= 200 mm
Ultimate Axial Load	= 1500 kN/m
Maximum Moment	= 92 kNm/m
Floor Height	= 5 m

Step 2 : Selection of preferred section

Refer to Index of Tables for Precast Components on Page 44-Page 46, to search for relevant Table of Component required. Information required is shown in Table 34 on Page 137.

Step 3 : Code of Component

Gather clear height, ultimate axial load value and maximum moment from Table 34 on Page 137 and select Code of Component. Select suitable component details based on values required. The Product Code WB200-02 then selected which contains following properties and conforms to given data as above.

Wall Thickness	= 200 mm
Ultimate Axial Load	= 1500 kN/m
Maximum Moment	= 92 kNm/m
Main Reinforcement (vertical/horizontal)	= T20-125 / T10-300

Example 6 : Precast Concrete Staircase

To design for precast staircase of 150 mm depth with maximum flight length of 3.0 m and floor height of maximum of 3.3 m. The compressive strength of precast staircase is $f_{cu} = 35$ N/mm².

Step 1 : List out given data as follows :-

Length of flight	= 3.0 m
Floor to floor height	= 3.3 m

Step 2 : Selection of preferred section

Refer to Index of Tables for Precast Components on Page 44-Page 46, to search for relevant Table of Component required. Information required is shown in Table 40, Table 41 and Table 42 on Page 159.

Step 3 : Code of Component

Gather length of staircase flight and floor to floor height from Table 40, Table 41 and Table 42 on Page 159 and select Product Code. Select suitable component details based on values required. The Product Code SC-150 then selected which contains following properties and conforms to given data as above.

Length of Flight	= 3.0 m
Floor to Floor Height	= 3.3 m
Thickness of precast staircase flight,	= 150 mm
Thickness of precast landing,	= 150 mm

Main Reinforcement :

Precast staircase :-

Bar 1 = R8-150	Bar 6 = T12-150
Bar 2 = R8-150	Bar 7 = T12-200
Bar 3 = 4T16	Bar 8 = T12-150
Bar 4 = T12-200	Bar 9 = T12-150
Bar 5 = 1T16	Bar 10 = 5T12

Landing slab : -

Bar 1 = 2T10-150

Bar 2 = 2T10-250

Mid-landing slab : -

Bar 1 = 2T10-100

Bar 2 = 2T10-150

Bar 3 = 2T10-150

Bar 4 = 2T10-250

Bar 5 = T10-250

Bar 6 = T10-250



PART 3

MANUAL FOR COMPONENTS SELECTIONS

Nib Schedule	
B2	H2
mm	mm
125	300 to 500
125	300 to 500
125	300 to 500
125	300 to 500

H1 = In order to...
selfweight of precast...
load and li...

Table 17

For span L=5m (the data shall a

Code of Component	Beam Sizes			kN/m	kN/m
	B1	H	H2		
mm	mm	mm	mm		
BTC-5060-L5	500	250	600	500	60
BTC-5070-L5	500	250	700	500	73
BTC-6060-L5	600	300	600	500	86
BTC-6070-L5	600	350	600	500	96

3.1 INDEX OF TABLES FOR PRECAST COMPONENTS

	Component	Code	Table No.	Page
A	Precast rectangular beam (simply supported)	BR		47
	1. Product description, specifications and reinforcement arrangement 2. Dimension, section properties and reinforcement details for: Span L=3m Span L=4m Span L=5m Span L=6m Span L=7m Span L=8m Span L=9m Span L=10m		Table 1 Table 2 Table 3 Table 4 Table 5 Table 6 Table 7 Table 8	49-50 51 53 55 57 59 60 61 62
B	Precast rectangular beam (continuous beam)	BRC		63
	1. Product description, specifications and reinforcement arrangement 2. Dimension, section properties and reinforcement details for: Span L = 3 m Span L = 4 m Span L = 5 m Span L = 6 m Span L = 7 m Span L = 8 m Span L = 9 m Span L = 10 m		Table 9 Table 10 Table 11 Table 12 Table 13 Table 14 Table 15 Table 16	65-66 67 69 71 73 75 77 78 79
C	Precast inverted T beam (continuous beam)	BTC		81
	1. Product description, specifications and reinforcement arrangement 2. Dimension, section properties and reinforcement details for: Span L = 5 m Span L = 7 m Span L = 9 m		Table 17 Table 18 Table 19	83-85 86 87 88
D	Precast edge beam (continuous beam)	BLC		89
	1. Product description, specifications and reinforcement arrangement 2. Dimension, section properties and reinforcement details for: Span L = 5 m Span L = 7 m Span L = 9 m		Table 20 Table 21 Table 22	91-93 94 95 96

	Component	Code	Table No.	Page
E	Precast square column	CS		97
	1. Product description, specifications and reinforcement arrangement 2. Dimension, section properties and reinforcement details		Table 23 Table 24 Table 25	99-101 102 104 106
F	Precast rectangular column	CR		109
	1. Product description, specifications and reinforcement arrangement 2. Dimension, section properties and reinforcement details		Table 26	111-113 114
G	Precast half slab (continuous supported)	HS		117
	1. Product description, specifications and reinforcement arrangement 2. Typical lattice girder detail 3. Dimension, section properties and reinforcement details for: Span L = 3 m Span L = 4 m Span L = 5 m		Table 27 Table 28 Table 29	119 120 121 121 121
H	Precast hollowcore slab	HCS		123
	1. Product description, specifications and reinforcement arrangement			125-126
I	Precast prestressed plank	PSP		127
	1. Product description, specifications and reinforcement arrangement 2. Dimension, section properties and reinforcement details		Table 30 Table 31 Table 32 Table 33	129-130 131 131 132 132
J	Precast wall (load bearing)	WB		133
	1. Product description, specifications and reinforcement arrangement 2. Dimension, section properties and reinforcement details		Table 34 Table 35 Table 36 Table 37 Table 38	135-136 137 138 139 140 141
K	Precast wall (non-load bearing)	NB		143
	1. Product description, specifications and reinforcement arrangement 2. Dimension, section properties and reinforcement details		Table 39	145-149 150

	Component	Code	Table No.	Page
L	Precast staircase	SC		151
	1. Product description, specifications and reinforcement arrangement 2. Dimension, section properties and reinforcement details		Table 40 Table 41 Table 42	153-158 159 159
M	Precast corbel connection			161
	1. Product description, specifications and reinforcement arrangement 2. Dimension, section properties and reinforcement details		Table 43 Table 44	162-164 165 165
N	Precast column nib connection			167
	1. Product description, specifications and reinforcement arrangement 2. Dimension, section properties and reinforcement details		Table 45	168-169 170
O	Precast half joint connection			171
	1. Product description, specifications and reinforcement arrangement 2. Dimension, section properties and reinforcement details		Table 46	172-173 172
P	Wet joint connection			175
	1. Product description, specifications and reinforcement arrangement			176-180



PRECAST COMPONENT

A. PRECAST RECTANGULAR BEAM (SIMPLY SUPPORTED)

- B. PRECAST RECTANGULAR BEAM (CONTINUOUS BEAM)
- C. PRECAST INVERTED T BEAM (CONTINUOUS BEAM)
- D. PRECAST EDGE BEAM (CONTINUOUS BEAM)
- E. PRECAST SQUARE COLUMN
- F. PRECAST RECTANGULAR COLUMN
- G. PRECAST HALF SLAB (CONTINUOUS SUPPORTED)
- H. PRECAST HOLLOWCORE SLAB
- I. PRECAST PRESTRESSED PLANK
- J. PRECAST WALL (LOAD BEARING)
- K. PRECAST WALL (NON-LOAD BEARING)
- L. PRECAST STAIRCASE
- M. PRECAST CORBEL CONNECTION
- N. PRECAST COLUMN NIB CONNECTION
- O. PRECAST HALF JOINT CONNECTION
- P. WET JOINT CONNECTION

NOTES

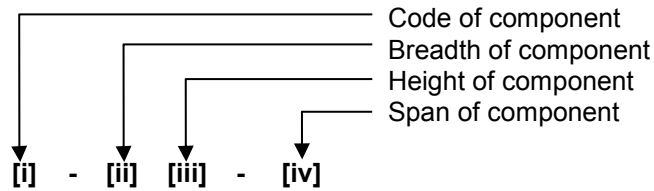

[i] Types of Component

Code	Component
BR	Precast rectangular beam (simply supported)

[ii] Breadth of Component

Depends on component range

[iii] Height of Component

Depends on component range

[iv] Span of Component

Depends on span of the component

Notation

M_u = Maximum moment capacity at mid span during final stage

V = Maximum shear capacity at the support during final stage

w = Uniformly distributed ultimate load during final stage

PRECAST BEAM – RECTANGULAR BEAM (SIMPLY SUPPORTED)

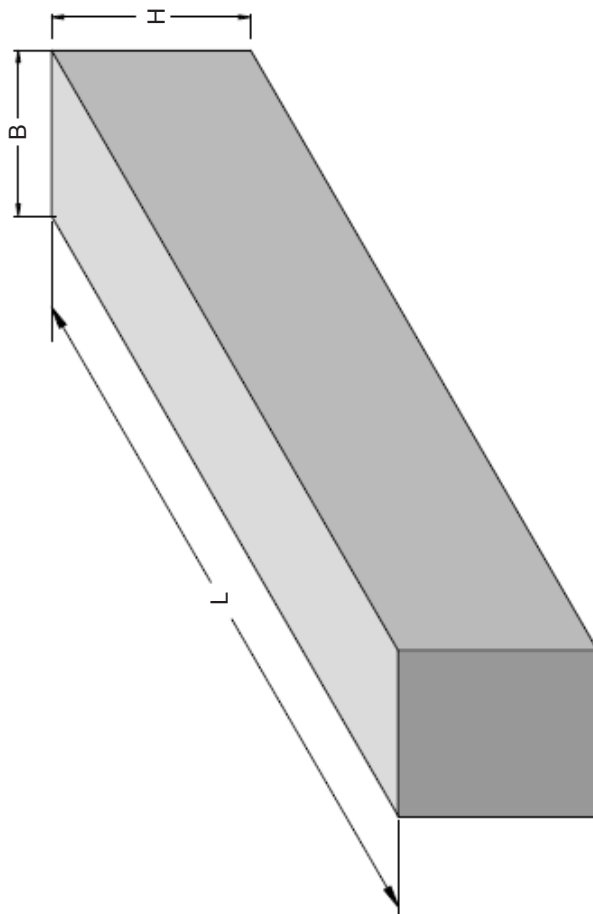

Simply supported beam – 3D view

CODE OF COMPONENTS

BR - 2030 - L3

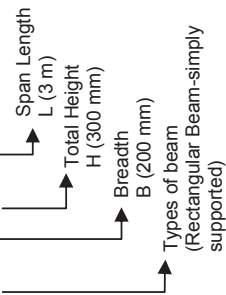

Specification

- a. Minimum concrete grade C35 (Precast and cast in-situ concrete) at final stage design.
- b. Minimum concrete compressive strength of 15 N/mm² for first lifting.
- c. The position of lifting hook at distance of 0.2L from end of beam and to be advised and checked by competent person.
- d. Minimum concrete compressive strength of 25 N/mm² for installation stage.
- e. Concrete cover to main reinforcement, minimum concrete cover to link for 2 hours: for simply supported beam = 40mm
- f. Characteristic of steel reinforcement
High tensile (T) $f_y = 460 \text{ N/mm}^2$
Mild steel (R) $f_{yv} = 250 \text{ N/mm}^2$
- g. The beam is designed as simply supported and unproped beam during installation stage and continuous unproped beam during final stage.
- h. Load should be uniformly distributed.
- i. During installation stage, perimeter beam is designed to support selfweight of beam only.
- j. M_r and V_r are calculated based on ultimate uniformly distributed load.
- k. The application of concentrated load area on precast element shall be referred to competent person.
- l. The connection system between precast component and cast in-situ structure shall be referred to competent person.
- m. The design has been prepared in accordance with the BS 8110 (1997).

PRECAST BEAM – RECTANGULAR BEAM (SIMPLY SUPPORTED) DETAILS

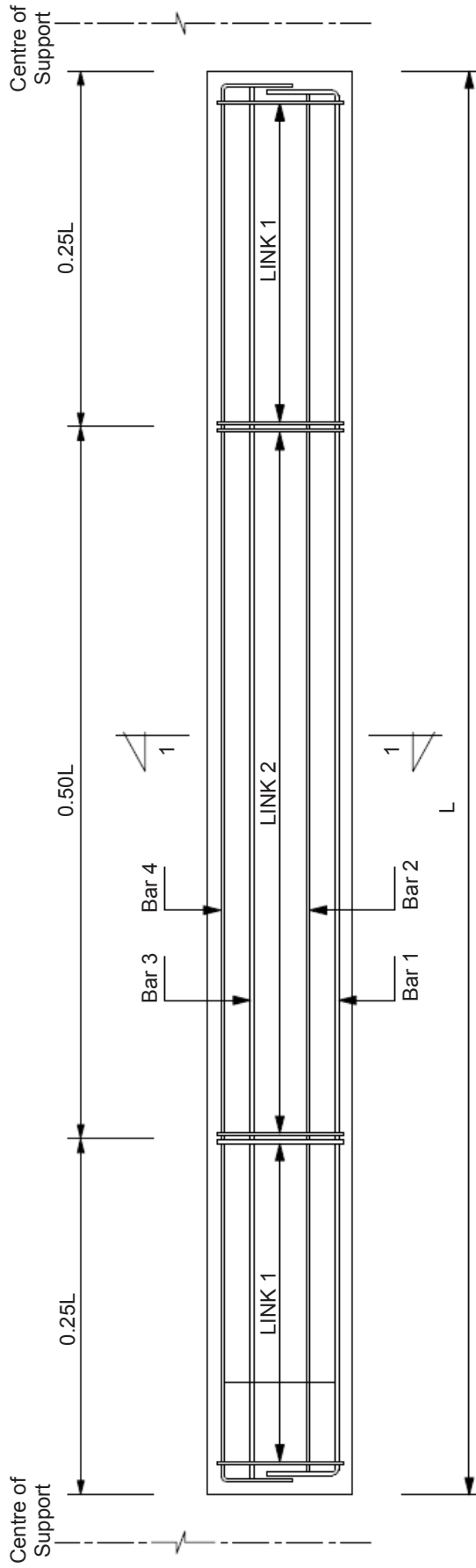

Elevation
Reinforcement arrangement

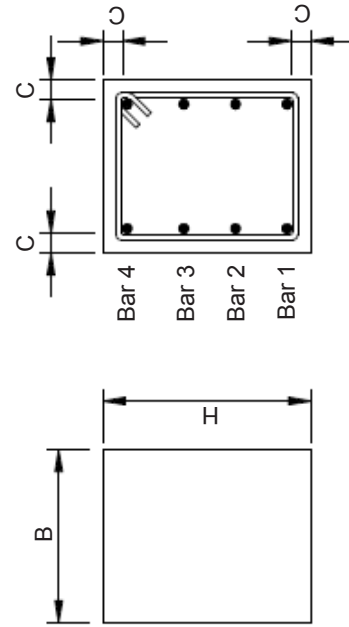

Cross section 1-1

Table 1

For span L=3m (the data shall applies for span length, L equal or less than 3m subjected to moment and shear capacity required)

Codes of Components	Beam Sizes		Final Design			Reinforcement Detail				Shear Links	
	B mm	H mm	UDL w kN/m	M _u kNm	V kN	Bar 1	Bar 2	Bar 3	Bar 4	Link 1	Link 2
BR-2030-L3	200	300	17	19	25	2T12	-	-	2T12	1R10-250	1R10-250
BR-2035-L3	200	350	20	23	30	2T12	-	-	2T12	1R10-250	1R10-250
BR-2040-L3	200	400	24	27	35	2T12	-	-	2T12	1R10-250	1R10-250
BR-2045-L3	200	450	27	30	41	2T12	-	-	2T12	1R10-250	1R10-250
BR-2050-L3	200	500	30	34	46	2T12	-	-	2T12	1R10-250	1R10-250
BR-2055-L3	200	550	34	38	51	2T12	-	-	2T12	1R10-250	1R10-250
BR-2060-L3	200	600	37	42	56	2T12	-	-	2T12	1R10-250	1R10-250
BR-2065-L3	200	650	41	46	61	2T12	-	-	2T12	1R10-250	1R10-250
BR-2070-L3	200	700	44	50	66	2T12	-	-	2T12	1R10-250	1R10-250
BR-2075-L3	200	750	48	54	71	2T12	2T12	2T12	2T12	1R10-250	1R10-250
BR-2080-L3	200	800	51	57	76	2T12	2T12	2T12	2T12	1R10-250	1R10-250
BR-2530-L3	250	300	26	29	39	3T12	-	-	2T12	1R10-250	1R10-250
BR-2535-L3	250	350	31	35	46	3T12	-	-	2T12	1R10-250	1R10-250
BR-2540-L3	250	400	36	40	54	3T12	-	-	2T12	1R10-250	1R10-250
BR-2545-L3	250	450	41	46	62	3T12	-	-	2T12	1R10-250	1R10-250
BR-2550-L3	250	500	46	52	69	3T12	-	-	2T12	1R10-250	1R10-250
BR-2555-L3	250	550	51	58	77	3T12	-	-	2T12	1R10-250	1R10-250
BR-2560-L3	250	600	57	64	85	3T12	-	-	2T16	1R10-250	1R10-250
BR-2565-L3	250	650	61	69	93	3T12	-	-	2T16	1R10-250	1R10-250
BR-2570-L3	250	700	67	75	100	3T12	-	-	2T16	1R10-250	1R10-250
BR-2575-L3	250	750	72	81	108	3T12	2T12	2T12	2T16	1R10-250	1R10-250
BR-2580-L3	250	800	77	87	116	3T12	2T12	2T12	2T16	1R10-250	1R10-250
BR-3030-L3	300	300	34	39	51	4T12	-	-	2T16	1R10-250	1R10-250
BR-3035-L3	300	350	41	46	62	4T12	-	-	2T16	1R10-250	1R10-250

Codes of Components	Beam Sizes		Final Design				Reinforcement Detail				Shear Links	
	B mm	H mm	UDL w kN/m	M _u kNm	V kN	Bar 1	Bar 2	Bar 3	Bar 4	Link 1	Link 2	
BR-3040-L3	300	400	48	54	72	4T12	-	-	2T16	1R10-250	1R10-250	
BR-3045-L3	300	450	55	62	82	4T12	-	-	2T16	1R10-250	1R10-250	
BR-3050-L3	300	500	61	69	93	4T12	-	-	2T16	1R10-250	1R10-250	
BR-3055-L3	300	550	68	77	103	4T12	-	-	2T16	1R10-250	1R10-250	
BR-3060-L3	300	600	75	85	113	4T12	-	-	2T16	1R10-250	1R10-250	
BR-3065-L3	300	650	82	93	123	4T12	-	-	2T16	1R10-250	1R10-250	
BR-3070-L3	300	700	89	100	134	4T12	-	-	2T16	1R10-250	1R10-250	
BR-3075-L3	300	750	96	108	144	4T12	2T12	2T12	2T16	1R10-250	1R10-250	
BR-3080-L3	300	800	103	116	154	4T12	2T12	2T12	2T16	1R10-250	1R10-250	
BR-3580-L3	350	800	105	120	156	4T16	2T16	2T16	2T16	1R10-250	1R10-250	

For reinforcement arrangement refer to page 49 - page 50

Table 2

For span L=4m (the data shall applies for span length, L equal or less than 4m subjected to moment and shear capacity required)

Code of Component	Beam Sizes		Final Design			Reinforcement Detail				Shear Links	
	B mm	H mm	UDL w kN/m	M _u kNm	V kN	Bar 1	Bar 2	Bar 3	Bar 4	Link 1	Link 2
BR-2030-L4	200	300	17	34	34	2T16	-	-	2T12	1R10-250	1R10-250
BR-2035-L4	200	350	21	41	41	2T16	-	-	2T12	1R10-250	1R10-250
BR-2040-L4	200	400	24	48	48	2T16	-	-	2T12	1R10-250	1R10-250
BR-2045-L4	200	450	27	55	55	2T16	-	-	2T12	1R10-250	1R10-250
BR-2050-L4	200	500	31	62	62	2T16	-	-	2T12	1R10-250	1R10-250
BR-2055-L4	200	550	34	69	69	2T16	-	-	2T12	1R10-250	1R10-250
BR-2060-L4	200	600	38	75	75	2T16	-	-	2T12	1R10-250	1R10-250
BR-2065-L4	200	650	41	82	82	2T16	-	-	2T12	1R10-250	1R10-250
BR-2070-L4	200	700	45	89	89	2T16	-	-	2T12	1R10-250	1R10-250
BR-2075-L4	200	750	48	96	96	2T16	2T16	2T16	2T12	1R10-250	1R10-250
BR-2080-L4	200	800	51	103	103	2T16	2T16	2T16	2T12	1R10-250	1R10-250
BR-2530-L4	250	300	26	51	51	3T16	-	-	2T12	1R10-250	1R10-250
BR-2535-L4	250	350	31	62	62	3T16	-	-	2T12	1R10-250	1R10-250
BR-2540-L4	250	400	36	72	72	3T16	-	-	2T12	1R10-250	1R10-250
BR-2545-L4	250	450	41	82	82	3T16	-	-	2T12	1R10-250	1R10-250
BR-2550-L4	250	500	46	93	93	3T16	-	-	2T12	1R10-250	1R10-250
BR-2555-L4	250	550	51	103	103	3T16	-	-	2T12	1R10-250	1R10-250
BR-2560-L4	250	600	57	113	113	3T16	-	-	2T16	1R10-250	1R10-250
BR-2565-L4	250	650	62	123	123	3T16	-	-	2T16	1R10-250	1R10-250
BR-2570-L4	250	700	67	134	134	3T16	-	-	2T16	1R10-250	1R10-250
BR-2575-L4	250	750	72	144	144	3T16	2T16	2T16	2T16	1R10-250	1R10-250
BR-2580-L4	250	800	77	154	154	3T16	2T16	2T16	2T16	1R10-250	1R10-250
BR-3030-L4	300	300	34	69	69	4T16	-	-	2T16	1R10-250	1R10-250
BR-3035-L4	300	350	41	82	82	4T16	-	-	2T16	1R10-250	1R10-250

Code of Component	Beam Sizes		Final Design				Reinforcement Detail				Shear Links	
	B mm	H mm	UDL w kN/m	M _u kNm	V kN	Bar 1	Bar 2	Bar 3	Bar 4	Link 1	Link 2	
BR-3040-L4	300	400	48	96	96	4T16	-	-	2T16	1R10-250	1R10-250	
BR-3045-L4	300	450	55	110	110	4T16	-	-	2T16	1R10-250	1R10-250	
BR-3050-L4	300	500	62	123	123	4T16	-	-	2T16	1R10-250	1R10-250	
BR-3055-L4	300	550	69	137	137	4T16	-	-	2T16	1R10-250	1R10-250	
BR-3060-L4	300	600	75	151	151	4T16	-	-	2T16	1R10-250	1R10-250	
BR-3065-L4	300	650	82	164	164	4T16	-	-	2T16	1R10-250	1R10-250	
BR-3070-L4	300	700	89	178	178	4T16	-	-	2T16	1R10-250	1R10-250	
BR-3075-L4	300	750	96	192	192	4T16	2T16	2T16	2T16	1R10-250	1R10-250	
BR-3080-L4	300	800	103	206	206	4T16	2T16	2T16	2T16	1R10-250	1R10-250	
BR-3580-L4	350	800	105	210	210	4T16	2T16	2T16	2T16	1R10-250	1R10-250	

For reinforcement arrangement refer to page 49 - page 50

Table 3

For span L=5m (the data shall applies for span length, L equal or less than 5m subjected to moment and shear capacity required)

Code of Component	Beam Sizes		Final Design			Reinforcement Detail				Shear Links	
	B mm	H mm	UDL w kN/m	M _u kNm	V kN	Bar 1	Bar 2	Bar 3	Bar 4	Link 1	Link 2
BR-2035-L5	200	350	20	62	49	3T16	-	-	2T12	1R10-250	1R10-250
BR-2040-L5	200	400	23	72	57	3T16	-	-	2T12	1R10-250	1R10-250
BR-2045-L5	200	450	26	82	65	3T16	-	-	2T12	1R10-250	1R10-250
BR-2050-L5	200	500	30	93	74	3T16	-	-	2T12	1R10-250	1R10-250
BR-2055-L5	200	550	33	103	82	3T16	-	-	2T12	1R10-250	1R10-250
BR-2060-L5	200	600	36	113	90	3T16	-	-	2T12	1R10-250	1R10-250
BR-2065-L5	200	650	39	123	98	3T16	-	-	2T12	1R10-250	1R10-250
BR-2070-L5	200	700	43	134	107	3T16	-	-	2T12	1R10-250	1R10-250
BR-2075-L5	200	750	46	144	115	3T16	2T16	2T16	2T12	1R10-250	1R10-250
BR-2080-L5	200	800	49	154	123	3T16	2T16	2T16	2T12	1R10-250	1R10-250
BR-2535-L5	250	350	26	82	65	4T16	-	-	2T12	1R10-250	1R10-250
BR-2540-L5	250	400	31	96	76	4T16	-	-	2T12	1R10-250	1R10-250
BR-2545-L5	250	450	35	110	88	4T16	-	-	2T12	1R10-250	1R10-250
BR-2550-L5	250	500	39	123	98	4T16	-	-	2T12	1R10-250	1R10-250
BR-2555-L5	250	550	44	137	109	4T16	-	-	2T12	1R10-250	1R10-250
BR-2560-L5	250	600	48	151	120	4T16	-	-	2T16	1R10-250	1R10-250
BR-2565-L5	250	650	52	164	131	4T16	-	-	2T16	1R10-250	1R10-250
BR-2570-L5	250	700	57	178	142	4T16	-	-	2T16	1R10-250	1R10-250
BR-2575-L5	250	750	61	192	153	4T16	2T16	2T16	2T16	1R10-250	1R10-250
BR-2580-L5	250	800	66	206	164	4T16	2T16	2T16	2T16	1R10-250	1R10-250
BR-3035-L5	300	350	33	103	82	5T16	-	-	2T16	1R10-250	1R10-250
BR-3040-L5	300	400	38	120	96	5T16	-	-	2T16	1R10-250	1R10-250
BR-3045-L5	300	450	44	137	109	5T16	-	-	2T16	1R10-250	1R10-250
BR-3050-L5	300	500	49	154	123	5T16	-	-	2T16	1R10-250	1R10-250

Code of Component	Beam Sizes		Final Design			Reinforcement Detail				Shear Links	
	B mm	H mm	UDL w kN/m	M _u kNm	V kN	Bar 1	Bar 2	Bar 3	Bar 4	Link 1	Link 2
BR-3055-L5	300	550	55	171	136	5T16	-	-	2T16	1R10-250	1R10-250
BR-3060-L5	300	600	60	188	150	5T16	-	-	2T16	1R10-250	1R10-250
BR-3065-L5	300	650	66	206	164	5T16	-	-	2T16	1R10-250	1R10-250
BR-3070-L5	300	700	71	223	178	5T16	-	-	2T16	1R10-250	1R10-250
BR-3075-L5	300	750	77	240	192	5T16	2T16	2T16	2T16	1R10-250	1R10-250
BR-3080-L5	300	800	82	257	205	5T16	2T16	2T16	2T16	1R10-250	1R10-250
BR-3580-L5	350	800	85	260	210	5T16	2T16	2T16	2T16	1R10-250	1R10-250

For reinforcement arrangement refer to page 49 - page 50

Table 4

For span L=6m (the data shall applies for span length, L equal or less than 6m subjected to moment and shear capacity required)

Code of Component	Beam Sizes		Final Design			Reinforcement Detail				Shear Links	
	B mm	H mm	UDL w kN/m	M _u kNm	V kN	Bar 1	Bar 2	Bar 3	Bar 4	Link 1	Link 2
BR-2040-L6	200	400	17	75	50	2T20	-	-	2T12	1R10-250	1R10-250
BR-2045-L6	200	450	19	86	57	2T20	-	-	2T12	1R10-250	1R10-250
BR-2050-L6	200	500	21	96	64	2T20	-	-	2T12	1R10-250	1R10-250
BR-2055-L6	200	550	24	107	71	2T20	-	-	2T12	1R10-250	1R10-250
BR-2060-L6	200	600	26	118	79	2T20	-	-	2T12	1R10-250	1R10-250
BR-2065-L6	200	650	29	129	86	2T20	-	-	2T12	1R10-250	1R10-250
BR-2070-L6	200	700	31	139	93	2T20	-	-	2T12	1R10-250	1R10-250
BR-2075-L6	200	750	33	150	100	2T20	2T16	2T16	2T12	1R10-250	1R10-250
BR-2080-L6	200	800	36	161	107	2T20	2T16	2T16	2T12	1R10-250	1R10-250
BR-2540-L6	250	400	25	112	75	3T20	-	-	2T12	1R10-250	1R10-250
BR-2545-L6	250	450	29	129	86	3T20	-	-	2T12	1R10-250	1R10-250
BR-2550-L6	250	500	32	145	96	3T20	-	-	2T12	1R10-250	1R10-250
BR-2555-L6	250	550	36	161	107	3T20	-	-	2T12	1R10-250	1R10-250
BR-2560-L6	250	600	39	177	118	3T20	-	-	2T16	1R10-250	1R10-250
BR-2565-L6	250	650	43	193	129	3T20	-	-	2T16	1R10-250	1R10-250
BR-2570-L6	250	700	46	209	139	3T20	-	-	2T16	1R10-250	1R10-250
BR-2575-L6	250	750	50	225	150	3T20	2T16	2T16	2T16	1R10-250	1R10-250
BR-2580-L6	250	800	54	241	161	3T20	2T16	2T16	2T16	1R10-250	1R10-250
BR-3040-L6	300	400	33	150	100	4T20	-	-	2T16	1R10-250	1R10-250
BR-3045-L6	300	450	38	171	114	4T20	-	-	2T16	1R10-250	1R10-250
BR-3050-L6	300	500	43	193	129	4T20	-	-	2T16	1R10-250	1R10-250
BR-3055-L6	300	550	48	214	143	4T20	-	-	2T16	1R10-250	1R10-250
BR-3060-L6	300	600	52	236	157	4T20	-	-	2T16	1R10-250	1R10-250
BR-3065-L6	300	650	57	257	171	4T20	-	-	2T16	1R10-250	1R10-250

Code of Component	Beam Sizes		Final Design			Reinforcement Detail				Shear Links	
	B mm	H mm	UDL w kN/m	M _u kNm	V kN	Bar 1	Bar 2	Bar 3	Bar 4	Link 1	Link 2
BR-3070-L6	300	700	62	278	185	4T20	-	-	2T16	1R10-250	1R10-250
BR-3075-L6	300	750	67	300	200	4T20	2T16	2T16	2T16	1R10-250	1R10-250
BR-3080-L6	300	800	71	321	214	4T20	2T16	2T16	2T16	1R10-250	1R10-250
BR-3580-L6	350	800	75	325	220	4T20	2T16	2T16	2T16	1R10-250	1R10-250

For reinforcement arrangement refer to page 49 - page 50

Table 5

For span L=7m (the data shall applies for span length, L equal or less than 7m subjected to moment and shear capacity required)

Code of Component	Beam Sizes		Final Design			Reinforcement Detail				Shear Links	
	B mm	H mm	UDL w kN/m	M _u kNm	V kN	Bar 1	Bar 2	Bar 3	Bar 4	Link 1	Link 2
BR-2045-L7	200	450	21	129	73	3T20	-	-	2T16	1R10-250	1R10-250
BR-2050-L7	200	500	24	145	83	3T20	-	-	2T16	1R10-250	1R10-250
BR-2055-L7	200	550	26	161	92	3T20	-	-	2T16	1R10-250	1R10-250
BR-2060-L7	200	600	29	177	101	3T20	-	-	2T16	1R10-250	1R10-250
BR-2065-L7	200	650	31	193	110	3T20	-	-	2T16	1R10-250	1R10-250
BR-2070-L7	200	700	34	209	119	3T20	-	-	2T16	1R10-250	1R10-250
BR-2075-L7	200	750	37	225	129	3T20	2T16	2T16	2T16	1R10-250	1R10-250
BR-2080-L7	200	800	39	241	138	3T20	2T16	2T16	2T16	1R10-250	1R10-250
BR-2545-L7	250	450	28	171	98	4T20	-	-	2T16	1R10-250	1R10-250
BR-2550-L7	250	500	31	193	110	4T20	-	-	2T16	1R10-250	1R10-250
BR-2555-L7	250	550	35	214	122	4T20	-	-	2T16	1R10-250	1R10-250
BR-2560-L7	250	600	38	236	135	4T20	-	-	2T16	1R10-250	1R10-250
BR-2565-L7	250	650	42	257	147	4T20	-	-	2T16	1R10-250	1R10-250
BR-2570-L7	250	700	45	278	159	4T20	-	-	2T16	1R10-250	1R10-250
BR-2575-L7	250	750	49	300	171	4T20	2T16	2T16	2T16	1R10-250	1R10-250
BR-2580-L7	250	800	52	321	183	4T20	2T16	2T16	2T16	1R10-250	1R10-250
BR-304-L75	300	450	35	214	122	5T20	-	-	2T16	1R10-250	1R10-250
BR-3050-L7	300	500	39	241	138	5T20	-	-	2T16	1R10-250	1R10-250
BR-3055-L7	300	550	44	268	153	5T20	-	-	2T16	1R10-250	1R10-250
BR-3060-L7	300	600	48	294	168	5T20	-	-	2T16	1R10-250	1R10-250
BR-3065-L7	300	650	52	321	183	5T20	-	-	2T16	1R10-250	1R10-250
BR-3070-L7	300	700	57	348	199	5T20	-	-	2T16	1R10-250	1R10-250
BR-3075-L7	300	750	61	375	214	5T20	2T16	2T16	2T16	1R10-250	1R10-250
BR-3080-L7	300	800	66	402	229	5T20	2T16	2T16	2T16	1R10-250	1R10-250

For reinforcement arrangement refer to page 49 - page 50

Table 6

For span **L=8m** (the data shall applies for span length, L equal or less than 8m subjected to moment and shear capacity required)

Code of Component	Beam Sizes		Final Design			Reinforcement Detail				Shear Links	
	B mm	H mm	UDL w kN/m	M _u kNm	V kN	Bar 1	Bar 2	Bar 3	Bar 4	Link 1	Link 2
BR-2050-L8	200	500	19	151	75	2T25	-	-	2T16	1R10-250	1R10-250
BR-2055-L8	200	550	21	167	84	2T25	-	-	2T16	1R10-250	1R10-250
BR-2060-L8	200	600	23	184	92	2T25	-	-	2T16	1R10-250	1R10-250
BR-2065-L8	200	650	25	201	100	2T25	-	-	2T16	1R10-250	1R10-250
BR-2070-L8	200	700	27	218	109	2T25	-	-	2T16	1R10-250	1R10-250
BR-2075-L8	200	750	29	234	117	2T25	2T16	2T16	2T16	1R10-250	1R10-250
BR-2080-L8	200	800	31	251	125	2T25	2T16	2T16	2T16	1R10-250	1R10-250
BR-2550-L8	250	500	28	226	113	3T25	-	-	2T16	1R10-250	1R10-250
BR-2555-L8	250	550	31	251	125	3T25	-	-	2T16	1R10-250	1R10-250
BR-2560-L8	250	600	35	276	138	3T25	-	-	2T16	1R10-250	1R10-250
BR-2565-L8	250	650	38	301	151	3T25	-	-	2T16	1R10-250	1R10-250
BR-2570-L8	250	700	41	326	163	3T25	-	-	2T16	1R10-250	1R10-250
BR-2575-L8	250	750	44	351	176	3T25	2T16	2T16	2T16	1R10-250	1R10-250
BR-2580-L8	250	800	47	376	188	3T25	2T16	2T16	2T16	1R10-250	1R10-250
BR-3050-L8	300	500	38	301	151	4T25	-	-	2T16	1R10-250	1R10-250
BR-3055-L8	300	550	42	335	167	4T25	-	-	2T16	1R10-250	1R10-250
BR-3060-L8	300	600	46	368	184	4T25	-	-	2T16	1R10-250	1R10-250
BR-3065-L8	300	650	50	402	201	4T25	-	-	2T16	1R10-250	1R10-250
BR-3070-L8	300	700	54	435	218	4T25	-	-	2T16	1R10-250	1R10-250
BR-3075-L8	300	750	59	468	234	4T25	2T16	2T16	2T16	1R10-250	1R10-250
BR-3080-L8	300	800	63	502	251	4T25	2T16	2T16	2T16	1R10-250	1R10-250
BR-3580-L8	350	800	68	410	234	5T20	2T16	2T16	2T16	1R10-250	1R10-250

For reinforcement arrangement refer to page 49 - page 50

Table 7

For span L=9m (the data shall applies for span length, L equal or less than 9m subjected to moment and shear capacity required)

Code of Component	Beam Sizes		Final Design			Reinforcement Detail				Shear Links	
	B mm	H mm	UDL w kN/m	M _u kNm	V kN	Bar 1	Bar 2	Bar 3	Bar 4	Link 1	Link 2
BR-2060-L9	200	600	18	184	82	2T25	-	-	2T16	1R10-200	1R10-250
BR-2065-L9	200	650	20	201	89	2T25	-	-	2T16	1R10-200	1R10-250
BR-2070-L9	200	700	21	218	97	2T25	-	-	2T16	1R10-200	1R10-250
BR-2075-L9	200	750	23	234	104	2T25	2T16	2T16	2T16	1R10-200	1R10-250
BR-2080-L9	200	800	25	251	112	2T25	2T16	2T16	2T16	1R10-200	1R10-250
BR-2560-L9	250	600	27	276	123	3T25	-	-	2T16	1R10-200	1R10-250
BR-2565-L9	250	650	30	301	134	3T25	-	-	2T16	1R10-200	1R10-250
BR-2570-L9	250	700	32	326	145	3T25	-	-	2T16	1R10-200	1R10-250
BR-2575-L9	250	750	35	351	156	3T25	2T16	2T16	2T16	1R10-200	1R10-250
BR-2580-L9	250	800	37	376	167	3T25	2T16	2T16	2T16	1R10-200	1R10-250
BR-3060-L9	300	600	36	368	164	4T25	-	-	2T16	1R10-200	1R10-250
BR-3065-L9	300	650	40	402	178	4T25	-	-	2T16	1R10-200	1R10-250
BR-3070-L9	300	700	43	435	193	4T25	-	-	2T16	1R10-200	1R10-250
BR-3075-L9	300	750	46	468	208	4T25	2T16	2T16	2T16	1R10-200	1R10-250
BR-3080-L9	300	800	50	502	223	4T25	2T16	2T16	2T16	1R10-200	1R10-250
BR-3580-L9	350	800	55	510	230	4T16	2T16	2T16	2T16	1R10-250	1R10-250

For reinforcement arrangement refer to page 49 - page 50

Table 8

For span **L=10m** (the data shall applies for span length, L equal or less than 10m subjected to moment and shear capacity required)

Code of Component	Beam Sizes		Final Design			Reinforcement Detail				Shear Links	
	B mm	H mm	UDL w kN/m	M _u kNm	V kN	Bar 1	Bar 2	Bar 3	Bar 4	Link 1	Link 2
BR-2070-L10	200	700	29	356	143	2T32	-	-	2T16	1R10-200	1R10-250
BR-2075-L10	200	750	31	384	154	2T32	2T16	2T16	2T16	1R10-200	1R10-250
BR-2080-L10	200	800	33	411	164	2T32	2T16	2T16	2T16	1R10-200	1R10-250
BR-2570-L10	250	700	43	535	214	3T32	-	-	2T16	1R10-200	1R10-250
BR-2575-L10	250	750	46	576	230	3T32	2T16	2T16	2T16	1R10-200	1R10-250
BR-2580-L10	250	800	49	617	247	3T32	2T16	2T16	2T16	1R10-200	1R10-250
BR-3070-L10	300	700	43	535	214	3T32	-	-	2T16	1R10-200	1R10-250
BR-3075-L10	300	750	61	768	307	4T32	2T16	2T16	2T16	1R10-150	1R10-250
BR-3080-L10	300	800	66	822	329	4T32	2T16	2T16	2T16	1R10-150	1R10-250
BR-3580-L10	350	800	70	840	340	4T16	2T16	2T16	2T16	1R10-250	1R10-250

For reinforcement arrangement refer to page page 49 - page 50



PRECAST COMPONENT

- A. PRECAST RECTANGULAR BEAM (SIMPLY SUPPORTED)
- B. PRECAST RECTANGULAR BEAM (CONTINUOUS BEAM)**
- C. PRECAST INVERTED T BEAM (CONTINUOUS BEAM)
- D. PRECAST EDGE BEAM (CONTINUOUS BEAM)
- E. PRECAST SQUARE COLUMN
- F. PRECAST RECTANGULAR COLUMN
- G. PRECAST HALF SLAB (CONTINUOUS SUPPORTED)
- H. PRECAST HOLLOWCORE SLAB
- I. PRECAST PRESTRESSED PLANK
- J. PRECAST WALL (LOAD BEARING)
- K. PRECAST WALL (NON-LOAD BEARING)
- L. PRECAST STAIRCASE
- M. PRECAST CORBEL CONNECTION
- N. PRECAST COLUMN NIB CONNECTION
- O. PRECAST HALF JOINT CONNECTION
- P. WET JOINT CONNECTION

NOTES

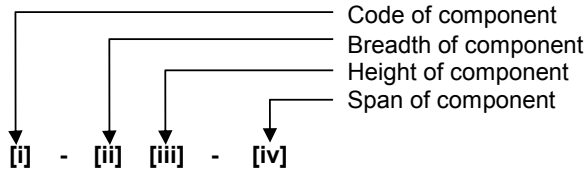

[i] Types of Component

Code	Component
BRC	Precast rectangular beam (continuous beam)

[ii] Breadth of Component

Depends on component range

[iii] Height of Component

Depends on component range

[iv] Span of Component

Depends on span of the component

Notation

- M_{mu} = Maximum moment capacity at mid span during final stage
- M_{su} = Maximum moment capacity at support during final stage
- V = Maximum shear capacity at the support during final stage
- w = Uniformly distributed ultimate load during final stage

PRECAST BEAM – RECTANGULAR BEAM (CONTINUOUS BEAM)

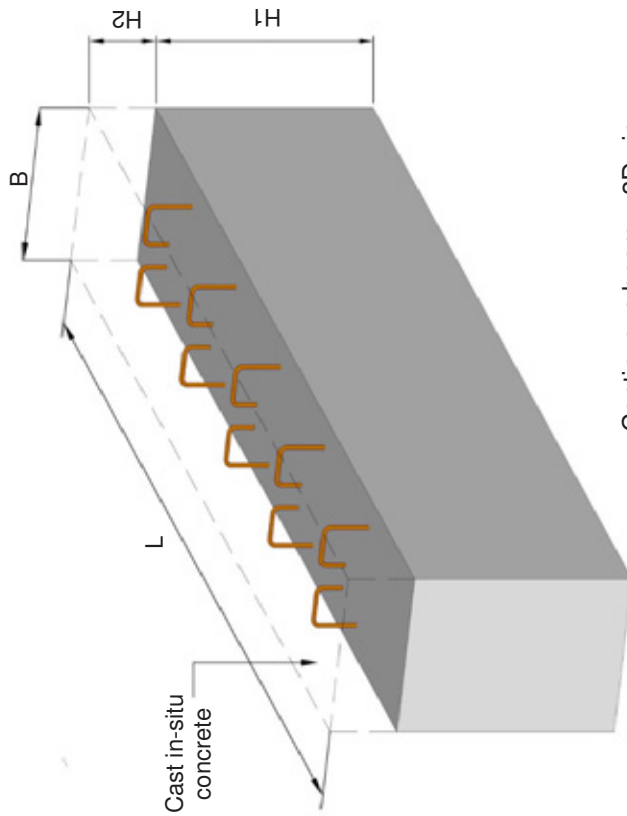

Continuous beam – 3D view

Lap schedule

Reinforcement Bar Size, (mm)	Lap Length, (mm)
12	500
16	650
20	800
25	1000
32	1300

CODE OF COMPONENTS

BRC - 2045 - L3

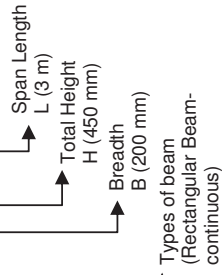

Specification

- Minimum concrete grade C35 (Precast and cast in-situ concrete) at final stage design.
- Minimum concrete compressive strength of 15 N/mm² for first lifting.
- The position of lifting hook at distance of 0.2L from end of beam and to be advised and checked by competent person.
- Minimum concrete compressive strength of 25 N/mm² for installation stage.
- Concrete cover to main reinforcement, minimum concrete cover to link for 2 hours : for continuous beam = 30mm
- Characteristic of steel reinforcement
High tensile (T) fy = 460 N/mm²
Mild steel (R) fyv = 250 N/mm²
- The beam are designed as simply supported and unpropped beam during installation stage and continuous unpropped beam during final stage.
- The hogging moment resistance at the support is provided by in-situ placed bar 4
- Load should be uniformly distributed.
- During installation stage, perimeter beam is designed to support selfweight of beam only.
- The application of concentrated load area on precast element shall be referred to competent person.
- M_{in}-span and M_{supp} values and shear shall refer to BS 8110 Part 1 cl. 3.4.3 and Table 3.6.
- The connection system between precast component and cast in-situ structure shall be referred to competent person.
- The design has been prepared in accordance with the BS 8110 (1997).

PRECAST BEAM – RECTANGULAR BEAM (CONTINUOUS BEAM) DETAILS

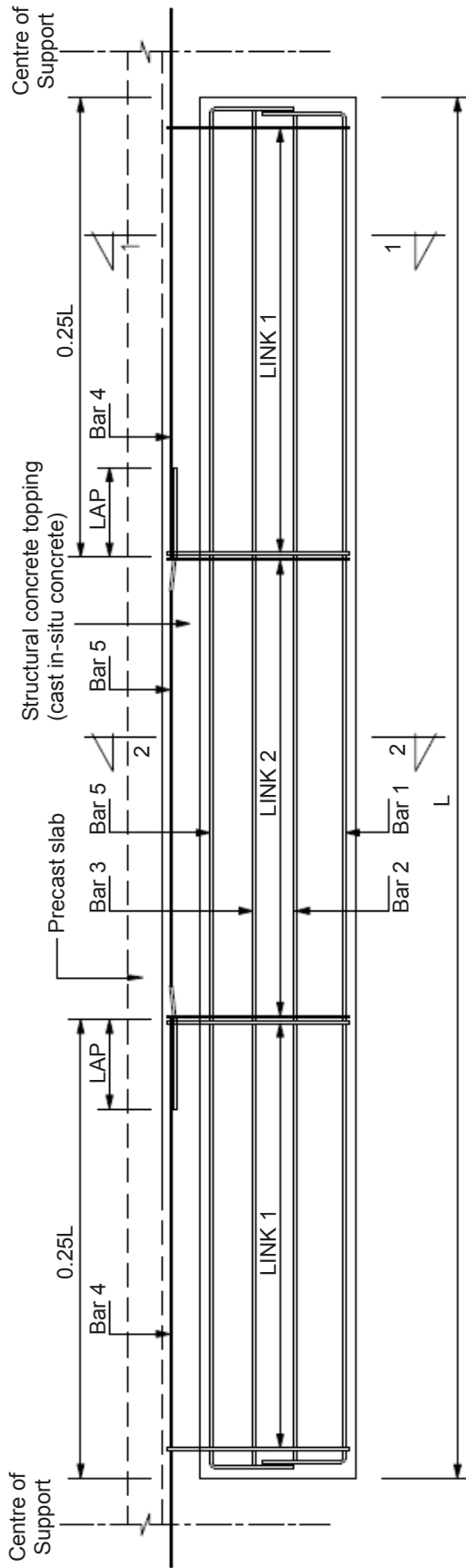

Elevation
Reinforcement arrangement

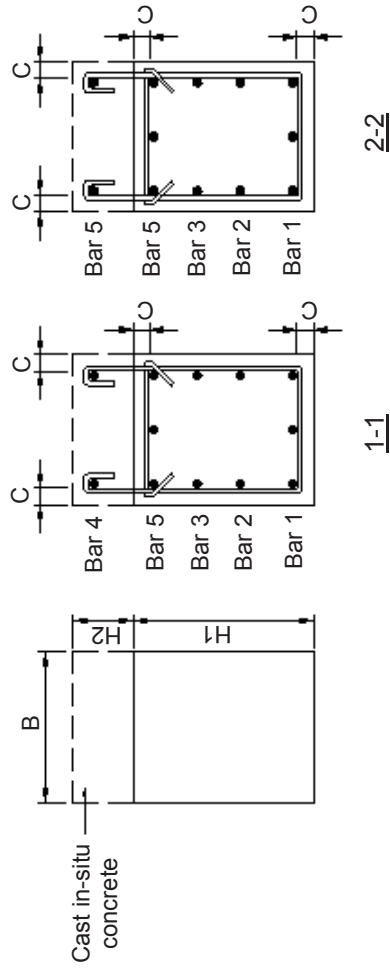

1-1
Cross section

2-2

Table 9

For span **L=3m** (the data shall applies for span length, L equal or less than 3m subjected to moment and shear capacity required)

Code of Component	Beam Sizes			Final Design			Reinforcement Detail					Shear Links	
	B mm	H1 mm	H2 mm	UDL w kN/m	M _{su} & M _{mu} kNm	V kN	Bar 1 & Bar 4	Bar 2	Bar 3	Bar 5	Link 1	Link 2	
BRC-2045-L3	200	300	150	27	31	49	2T12	-	-	2T12	1R10-250	1R10-250	
BRC-2050-L3	200	350	150	31	35	56	2T12	-	-	2T12	1R10-250	1R10-250	
BRC-2055-L3	200	400	150	34	39	62	2T12	-	-	2T12	1R10-250	1R10-250	
BRC-2060-L3	200	450	150	38	42	68	2T12	-	-	2T12	1R10-250	1R10-250	
BRC-2065-L3	200	500	150	41	46	74	2T12	-	-	2T12	1R10-250	1R10-250	
BRC-2070-L3	200	550	150	45	50	80	2T12	-	-	2T12	1R10-250	1R10-250	
BRC-2075-L3	200	600	150	48	54	86	2T12	2T16	2T12	2T12	1R10-250	1R10-250	
BRC-2080-L3	200	650	150	51	58	93	2T12	2T16	2T12	2T12	1R10-250	1R10-250	
BRC-2545-L3	250	300	150	41	46	74	3T12	-	-	2T16	1R10-250	1R10-250	
BRC-2550-L3	250	350	150	46	52	83	3T12	-	-	2T16	1R10-250	1R10-250	
BRC-2555-L3	250	400	150	51	58	93	3T12	-	-	2T16	1R10-250	1R10-250	
BRC-2560-L3	250	450	150	57	64	102	3T12	-	-	2T16	1R10-250	1R10-250	
BRC-2565-L3	250	500	150	62	69	111	3T12	-	-	2T16	1R10-250	1R10-250	
BRC-2570-L3	250	550	150	67	75	120	3T12	-	-	2T16	1R10-250	1R10-250	
BRC-2575-L3	250	600	150	72	81	130	3T12	2T16	2T16	2T16	1R10-250	1R10-250	
BRC-2580-L3	250	650	150	77	87	139	3T12	2T16	2T16	2T16	1R10-250	1R10-250	
BRC-3045-L3	300	300	150	55	62	99	4T12	-	-	2T16	1R10-250	1R10-250	
BRC-3050-L3	300	350	150	62	69	111	4T12	-	-	2T16	1R10-250	1R10-250	
BRC-3055-L3	300	400	150	69	77	123	4T12	-	-	2T16	1R10-250	1R10-250	
BRC-3060-L3	300	450	150	75	85	136	4T12	-	-	2T16	1R10-250	1R10-250	
BRC-3065-L3	300	500	150	82	93	148	4T12	-	-	2T16	1R10-250	1R10-250	
BRC-3070-L3	300	550	150	89	100	160	4T12	-	-	2T16	1R10-250	1R10-250	
BRC-3075-L3	300	600	150	96	108	173	4T12	2T16	2T16	2T16	1R10-250	1R10-250	
BRC-3080-L3	300	650	150	103	116	185	4T12	2T16	2T16	2T16	1R10-250	1R10-250	
BRC-3545-L3	350	300	150	69	77	123	5T12	-	-	2T16	1R10-200	1R10-250	
BRC-3550-L3	350	350	150	77	87	139	5T12	-	-	2T16	1R10-200	1R10-250	
BRC-3555-L3	350	400	150	86	96	154	5T12	-	-	2T16	1R10-200	1R10-250	
BRC-3560-L3	350	450	150	94	106	170	5T12	-	-	2T16	1R10-200	1R10-250	

Code of Component	Beam Sizes			Final Design				Reinforcement Detail					Shear Links	
	B	H1	H2	UDL	M _{su} & M _{mu}	V	Bar 1 & Bar 4	Bar 2	Bar 3	Bar 5	Link 1	Link 2		
	mm	mm	mm	w kN/m	kNm	kN								
BRC-3565-L3	350	500	150	103	116	185	5T12	-	-	2T16	1R10-200	1R10-250		
BRC-3570-L3	350	550	150	111	125	200	5T12	-	-	2T16	1R10-200	1R10-250		
BRC-3575-L3	350	600	150	120	135	216	5T12	2T16	2T16	2T16	1R10-200	1R10-250		
BRC-3580-L3	350	650	150	129	145	231	5T12	2T16	2T16	2T16	1R10-200	1R10-250		
BRC-4045-L3	400	300	150	82	93	148	6T12	-	-	2T20	1R10-150	1R10-250		
BRC-4050-L3	400	350	150	93	104	167	6T12	-	-	2T20	1R10-150	1R10-250		
BRC-4055-L3	400	400	150	103	116	185	6T12	-	-	2T20	1R10-150	1R10-250		
BRC-4060-L3	400	450	150	113	127	204	6T12	-	-	2T20	1R10-150	1R10-250		
BRC-4065-L3	400	500	150	123	139	222	6T12	-	-	2T20	1R10-150	1R10-250		
BRC-4070-L3	400	550	150	134	150	241	6T12	-	-	2T20	1R10-150	1R10-250		
BRC-4075-L3	400	600	150	144	162	259	6T12	2T16	2T16	2T20	1R10-150	1R10-250		
BRC-4080-L3	400	650	150	154	173	278	6T12	2T16	2T16	2T20	1R10-150	1R10-250		

For reinforcement arrangement refer to page 65 - page 66

Table 10

For span **L=4m** (the data shall applies for span length, L equal or less than 4m subjected to moment and shear capacity required)

Code of Component	Beam Sizes			Final Design			Reinforcement Detail					Shear Links	
	B mm	H1 mm	H2 mm	UDL w kN/m	M _{su} & M _{mu} kNm	V kN	Bar 1 & Bar 4	Bar 2	Bar 3	Bar 5	Link 1	Link 2	
BRC-2045-L4	200	300	150	27	55	66	2T16	-	-	2T12	1R10-250	1R10-250	
BRC-2050-L4	200	350	150	31	62	74	2T16	-	-	2T12	1R10-250	1R10-250	
BRC-2055-L4	200	400	150	34	69	82	2T16	-	-	2T12	1R10-250	1R10-250	
BRC-2060-L4	200	450	150	38	75	90	2T16	-	-	2T12	1R10-250	1R10-250	
BRC-2065-L4	200	500	150	41	82	99	2T16	-	-	2T12	1R10-250	1R10-250	
BRC-2070-L4	200	550	150	45	89	107	2T16	-	-	2T12	1R10-250	1R10-250	
BRC-2075-L4	200	600	150	48	96	115	2T16	2T16	2T12	2T12	1R10-250	1R10-250	
BRC-2080-L4	200	650	150	51	103	123	2T16	2T16	2T12	2T12	1R10-250	1R10-250	
BRC-2545-L4	250	300	150	41	82	99	3T16	-	-	2T12	1R10-250	1R10-250	
BRC-2550-L4	250	350	150	46	93	111	3T16	-	-	2T12	1R10-250	1R10-250	
BRC-2555-L4	250	400	150	51	103	123	3T16	-	-	2T12	1R10-250	1R10-250	
BRC-2560-L4	250	450	150	57	113	136	3T16	-	-	2T12	1R10-250	1R10-250	
BRC-2565-L4	250	500	150	62	123	148	3T16	-	-	2T16	1R10-250	1R10-250	
BRC-2570-L4	250	550	150	67	134	160	3T16	-	-	2T16	1R10-250	1R10-250	
BRC-2575-L4	250	600	150	72	144	173	3T16	2T16	2T16	2T16	1R10-250	1R10-250	
BRC-2580-L4	250	650	150	77	154	185	3T16	2T16	2T16	2T16	1R10-250	1R10-250	
BRC-3045-L4	300	300	150	55	110	132	4T16	-	-	2T16	1R10-200	1R10-250	
BRC-3050-L4	300	350	150	62	123	148	4T16	-	-	2T16	1R10-200	1R10-250	
BRC-3055-L4	300	400	150	69	137	164	4T16	-	-	2T16	1R10-200	1R10-250	
BRC-3060-L4	300	450	150	75	151	181	4T16	-	-	2T16	1R10-200	1R10-250	
BRC-3065-L4	300	500	150	82	164	197	4T16	-	-	2T16	1R10-200	1R10-250	
BRC-3070-L4	300	550	150	89	178	214	4T16	-	-	2T16	1R10-200	1R10-250	
BRC-3075-L4	300	600	150	96	192	230	4T16	2T16	2T16	2T16	1R10-200	1R10-250	
BRC-3080-L4	300	650	150	103	206	247	4T16	2T16	2T16	2T16	1R10-200	1R10-250	
BRC-3545-L4	350	300	150	69	137	164	5T16	-	-	2T16	1R10-150	1R10-250	
BRC-3550-L4	350	350	150	77	154	185	5T16	-	-	2T16	1R10-150	1R10-250	
BRC-3555-L4	350	400	150	86	171	206	5T16	-	-	2T16	1R10-150	1R10-250	
BRC-3560-L4	350	450	150	94	188	226	5T16	-	-	2T16	1R10-150	1R10-250	

Code of Component	Beam Sizes			Final Design			Reinforcement Detail					Shear Links	
	B	H1	H2	UDL	M _{su} & M _{mu}	V	Bar 1 & Bar 4	Bar 2	Bar 3	Bar 5	Link 1	Link 2	
	mm	mm	mm	w kN/m	kNm	kN							
BRC-3565-L4	350	500	150	103	206	247	5T16	-	-	2T16	1R10-150	1R10-250	
BRC-3570-L4	350	550	150	111	223	267	5T16	-	-	2T16	1R10-150	1R10-250	
BRC-3575-L4	350	600	150	120	240	288	5T16	2T16	2T16	2T16	1R10-150	1R10-250	
BRC-3580-L4	350	650	150	129	257	308	5T16	2T16	2T16	2T16	1R10-150	1R10-250	
BRC-4045-L4	400	300	150	82	164	197	6T16	-	-	2T20	1R10-100	1R10-200	
BRC-4050-L4	400	350	150	93	185	222	6T16	-	-	2T20	1R10-100	1R10-200	
BRC-4055-L4	400	400	150	103	206	247	6T16	-	-	2T20	1R10-100	1R10-200	
BRC-4060-L4	400	450	150	113	226	271	6T16	-	-	2T20	1R10-100	1R10-200	
BRC-4065-L4	400	500	150	123	247	296	6T16	-	-	2T20	1R10-100	1R10-200	
BRC-4070-L4	400	550	150	134	267	321	6T16	-	-	2T20	1R10-100	1R10-200	
BRC-4075-L4	400	600	150	144	288	345	6T16	2T16	2T16	2T20	1R10-100	1R10-200	
BRC-4080-L4	400	650	150	154	308	370	6T16	2T16	2T16	2T20	1R10-100	1R10-200	

For reinforcement arrangement refer to page 65 - page 66

Table 11

For span **L=5m** (the data shall applies for span length, L equal or less than 5m subjected to moment and shear capacity required)

Code of Component	Beam Sizes			Final Design			Reinforcement Detail				Shear Links	
	B mm	H1 mm	H2 mm	UDL w kN/m	M _{su} & M _{mu} kNm	V kN	Bar 1 & Bar 4	Bar 2	Bar 3	Bar 5	Link 1	Link 2
BRC-2045-L5	200	300	150	26	82	79	3T16	-	-	2T12	1R10-250	1R10-250
BRC-2050-L5	200	350	150	30	93	89	3T16	-	-	2T12	1R10-250	1R10-250
BRC-2055-L5	200	400	150	33	103	99	3T16	-	-	2T12	1R10-250	1R10-250
BRC-2060-L5	200	450	150	36	113	109	3T16	-	-	2T12	1R10-250	1R10-250
BRC-2065-L5	200	500	150	39	123	118	3T16	-	-	2T12	1R10-250	1R10-250
BRC-2070-L5	200	550	150	43	134	128	3T16	-	-	2T12	1R10-250	1R10-250
BRC-2075-L5	200	600	150	46	144	138	3T16	2T16	2T16	2T12	1R10-250	1R10-250
BRC-2080-L5	200	650	150	49	154	148	3T16	2T16	2T16	2T12	1R10-250	1R10-250
BRC-2545-L5	250	300	150	35	110	105	4T16	-	-	2T12	1R10-250	1R10-250
BRC-2550-L5	250	350	150	39	123	118	4T16	-	-	2T12	1R10-250	1R10-250
BRC-2555-L5	250	400	150	44	137	132	4T16	-	-	2T12	1R10-250	1R10-250
BRC-2560-L5	250	450	150	48	151	145	4T16	-	-	2T12	1R10-250	1R10-250
BRC-2565-L5	250	500	150	53	164	158	4T16	-	-	2T16	1R10-250	1R10-250
BRC-2570-L5	250	550	150	57	178	171	4T16	-	-	2T16	1R10-250	1R10-250
BRC-2575-L5	250	600	150	61	192	184	4T16	2T16	2T16	2T16	1R10-250	1R10-250
BRC-2580-L5	250	650	150	66	206	197	4T16	2T16	2T16	2T16	1R10-250	1R10-250
BRC-3045-L5	300	300	150	44	137	132	5T16	-	-	2T16	1R10-200	1R10-250
BRC-3050-L5	300	350	150	49	154	148	5T16	-	-	2T16	1R10-200	1R10-250
BRC-3055-L5	300	400	150	55	171	164	5T16	-	-	2T16	1R10-200	1R10-250
BRC-3060-L5	300	450	150	60	188	181	5T16	-	-	2T16	1R10-200	1R10-250
BRC-3065-L5	300	500	150	66	206	197	5T16	-	-	2T16	1R10-200	1R10-250
BRC-3070-L5	300	550	150	71	223	214	5T16	-	-	2T16	1R10-200	1R10-250
BRC-3075-L5	300	600	150	77	240	230	5T16	2T16	2T16	2T16	1R10-200	1R10-250
BRC-3080-L5	300	650	150	82	257	247	5T16	2T16	2T16	2T16	1R10-200	1R10-250
BRC-3545-L5	350	300	150	53	164	158	6T16	-	-	2T16	1R10-150	1R10-250
BRC-3550-L5	350	350	150	59	185	178	6T16	-	-	2T16	1R10-150	1R10-250
BRC-3555-L5	350	400	150	66	206	197	6T16	-	-	2T16	1R10-150	1R10-250
BRC-3560-L5	350	450	150	72	226	217	6T16	-	-	2T16	1R10-150	1R10-250
BRC-3565-L5	350	500	150	79	247	237	6T16	-	-	2T16	1R10-150	1R10-250
BRC-3570-L5	350	550	150	86	267	257	6T16	-	-	2T16	1R10-150	1R10-250

Code of Component	Beam Sizes			Final Design				Reinforcement Detail					Shear Links	
	B	H1	H2	UDL	M _{su} & M _{mu}	V	Bar 1 & Bar 4	Bar 2	Bar 3	Bar 5	Link 1	Link 2		
	mm	mm	mm	w kN/m	kNm	kN								
BRC-3575-L5	350	600	150	92	288	276	6T16	2T16	2T16	2T16	1R10-150	1R10-250		
BRC-3580-L5	350	650	150	99	308	296	6T16	2T16	2T16	2T16	1R10-150	1R10-250		
BRC-4045-L5	400	300	150	61	192	184	7T16	-	-	2T20	1R10-100	1R10-200		
BRC-4050-L5	400	350	150	69	216	207	7T16	-	-	2T20	1R10-100	1R10-200		
BRC-4055-L5	400	400	150	77	240	230	7T16	-	-	2T20	1R10-100	1R10-200		
BRC-4060-L5	400	450	150	84	264	253	7T16	-	-	2T20	1R10-100	1R10-200		
BRC-4065-L5	400	500	150	92	288	276	7T16	-	-	2T20	1R10-100	1R10-200		
BRC-4070-L5	400	550	150	100	312	299	7T16	-	-	2T20	1R10-100	1R10-200		
BRC-4075-L5	400	600	150	107	336	322	7T16	2T16	2T16	2T20	1R10-100	1R10-200		
BRC-4080-L5	400	650	150	115	360	345	7T16	2T16	2T16	2T20	1R10-100	1R10-200		

For reinforcement arrangement refer to page 65 - page 66

Table 12

For span L=6m (the data shall applies for span length, L equal or less than 6m subjected to moment and shear capacity required)

Code of Component	Beam Sizes			Final Design			Reinforcement Detail				Shear Links	
	B mm	H1 mm	H2 mm	UDL w kN/m	M _{su} & M _{mu} kNm	V kN	Bar 1 & Bar 4	Bar 2	Bar 3	Bar 5	Link 1	Link 2
BRC-2045-L6	200	300	150	19	86	69	2T20	-	-	2T12	1R10-250	1R10-250
BRC-2050-L6	200	350	150	21	96	77	2T20	-	-	2T12	1R10-250	1R10-250
BRC-2055-L6	200	400	150	24	107	86	2T20	-	-	2T12	1R10-250	1R10-250
BRC-2060-L6	200	450	150	26	118	94	2T20	-	-	2T12	1R10-250	1R10-250
BRC-2065-L6	200	500	150	29	129	103	2T20	-	-	2T12	1R10-250	1R10-250
BRC-2070-L6	200	550	150	31	139	111	2T20	-	-	2T12	1R10-250	1R10-250
BRC-2075-L6	200	600	150	33	150	120	2T20	2T16	2T16	2T12	1R10-250	1R10-250
BRC-2080-L6	200	650	150	36	161	129	2T20	2T16	2T16	2T12	1R10-250	1R10-250
BRC-2545-L6	250	300	150	29	129	103	3T20	-	-	2T12	1R10-250	1R10-250
BRC-2550-L6	250	350	150	32	145	116	3T20	-	-	2T12	1R10-250	1R10-250
BRC-2555-L6	250	400	150	36	161	129	3T20	-	-	2T12	1R10-250	1R10-250
BRC-2560-L6	250	450	150	39	177	141	3T20	-	-	2T12	1R10-250	1R10-250
BRC-2565-L6	250	500	150	43	193	154	3T20	-	-	2T16	1R10-250	1R10-250
BRC-2570-L6	250	550	150	46	209	167	3T20	-	-	2T16	1R10-250	1R10-250
BRC-2575-L6	250	600	150	50	225	180	3T20	2T16	2T16	2T16	1R10-250	1R10-250
BRC-2580-L6	250	650	150	54	241	193	3T20	2T16	2T16	2T16	1R10-250	1R10-250
BRC-3045-L6	300	300	150	38	171	137	4T20	-	-	2T16	1R10-200	1R10-250
BRC-3050-L6	300	350	150	43	193	154	4T20	-	-	2T16	1R10-200	1R10-250
BRC-3055-L6	300	400	150	48	214	171	4T20	-	-	2T16	1R10-200	1R10-250
BRC-3060-L6	300	450	150	52	236	188	4T20	-	-	2T16	1R10-200	1R10-250
BRC-3065-L6	300	500	150	57	257	206	4T20	-	-	2T16	1R10-200	1R10-250
BRC-3070-L6	300	550	150	62	278	223	4T20	-	-	2T16	1R10-200	1R10-250
BRC-3075-L6	300	600	150	67	300	240	4T20	2T16	2T16	2T16	1R10-200	1R10-250
BRC-3080-L6	300	650	150	71	321	257	4T20	2T16	2T16	2T16	1R10-200	1R10-250
BRC-3545-L6	350	300	150	48	214	171	5T20	-	-	2T16	1R10-150	1R10-250
BRC-3550-L6	350	350	150	54	241	193	5T20	-	-	2T16	1R10-150	1R10-250
BRC-3555-L6	350	400	150	59	268	214	5T20	-	-	2T16	1R10-150	1R10-250
BRC-3560-L6	350	450	150	65	294	236	5T20	-	-	2T16	1R10-150	1R10-250
BRC-3565-L6	350	500	150	71	321	257	5T20	-	-	2T16	1R10-150	1R10-250
BRC-3570-L6	350	550	150	77	348	278	5T20	-	-	2T16	1R10-150	1R10-250

Code of Component	Beam Sizes			Final Design				Reinforcement Detail					Shear Links	
	B	H1	H2	UDL	M _{su} & M _{mu}	V	Bar 1 & Bar 4	Bar 2	Bar 3	Bar 5	Link 1	Link 2		
	mm	mm	mm	w kN/m	kNm	kN								
BRC-3575-L6	350	600	150	83	375	300	5T20	2T16	2T16	2T16	1R10-150	1R10-250		
BRC-3580-L6	350	650	150	89	402	321	5T20	2T16	2T16	2T16	1R10-150	1R10-250		
BRC-4045-L6	400	300	150	57	257	206	6T20	-	-	2T20	1R10-100	1R10-200		
BRC-4050-L6	400	350	150	64	289	231	6T20	-	-	2T20	1R10-100	1R10-200		
BRC-4055-L6	400	400	150	71	321	257	6T20	-	-	2T20	1R10-100	1R10-200		
BRC-4060-L6	400	450	150	79	353	283	6T20	-	-	2T20	1R10-100	1R10-200		
BRC-4065-L6	400	500	150	86	386	308	6T20	-	-	2T20	1R10-100	1R10-200		
BRC-4070-L6	400	550	150	93	418	334	6T20	-	-	2T20	1R10-100	1R10-200		
BRC-4075-L6	400	600	150	100	450	360	6T20	2T16	2T16	2T20	1R10-100	1R10-200		
BRC-4080-L6	400	650	150	107	482	386	6T20	2T16	2T16	2T20	1R10-100	1R10-200		

For reinforcement arrangement refer to page 65 - page 66

Table 13

For span L=7m (the data shall applies for span length, L equal or less than 7m subjected to moment and shear capacity required)

Code of Component	Beam Sizes			Final Design			Reinforcement Detail					Shear Links	
	B	H1	H2	UDL	M _{su} & M _{mu}	V	Bar 1 & Bar 4	Bar 2	Bar 3	Bar 5	Link 1	Link 2	
	mm	mm	mm	w kN/m	kNm	kN							
BRC-2045-L7	200	300	150	21	129	88	3T20	-	-	2T12	1R10-250	1R10-250	
BRC-2050-L7	200	350	150	24	145	99	3T20	-	-	2T12	1R10-250	1R10-250	
BRC-2055-L7	200	400	150	26	161	110	3T20	-	-	2T12	1R10-250	1R10-250	
BRC-2060-L7	200	450	150	29	177	121	3T20	-	-	2T12	1R10-250	1R10-250	
BRC-2065-L7	200	500	150	31	193	132	3T20	-	-	2T12	1R10-250	1R10-250	
BRC-2070-L7	200	550	150	34	209	143	3T20	-	-	2T12	1R10-250	1R10-250	
BRC-2075-L7	200	600	150	37	225	154	3T20	2T16	2T16	2T12	1R10-250	1R10-250	
BRC-2080-L7	200	650	150	39	241	165	3T20	2T16	2T16	2T12	1R10-250	1R10-250	
BRC-2545-L7	250	300	150	28	171	117	4T20	-	-	2T12	1R10-250	1R10-250	
BRC-2550-L7	250	350	150	31	193	132	4T20	-	-	2T12	1R10-250	1R10-250	
BRC-2555-L7	250	400	150	35	214	147	4T20	-	-	2T12	1R10-250	1R10-250	
BRC-2560-L7	250	450	150	38	236	162	4T20	-	-	2T12	1R10-250	1R10-250	
BRC-2565-L7	250	500	150	42	257	176	4T20	-	-	2T16	1R10-250	1R10-250	
BRC-2570-L7	250	550	150	45	278	191	4T20	-	-	2T16	1R10-250	1R10-250	
BRC-2575-L7	250	600	150	49	300	206	4T20	2T16	2T16	2T16	1R10-250	1R10-250	
BRC-2580-L7	250	650	150	52	321	220	4T20	2T16	2T16	2T16	1R10-250	1R10-250	
BRC-3045-L7	300	300	150	35	214	147	5T20	-	-	2T16	1R10-200	1R10-250	
BRC-3050-L7	300	350	150	39	241	165	5T20	-	-	2T16	1R10-200	1R10-250	
BRC-3055-L7	300	400	150	44	268	184	5T20	-	-	2T16	1R10-200	1R10-250	
BRC-3060-L7	300	450	150	48	294	202	5T20	-	-	2T16	1R10-200	1R10-250	
BRC-3065-L7	300	500	150	52	321	220	5T20	-	-	2T16	1R10-200	1R10-250	
BRC-3070-L7	300	550	150	57	348	239	5T20	-	-	2T16	1R10-200	1R10-250	
BRC-3075-L7	300	600	150	61	375	257	5T20	2T16	2T16	2T16	1R10-200	1R10-250	
BRC-3080-L7	300	650	150	66	402	275	5T20	2T16	2T16	2T16	1R10-200	1R10-250	
BRC-3545-L7	350	300	150	42	257	176	6T20	-	-	2T16	1R10-150	1R10-250	
BRC-3550-L7	350	350	150	47	289	198	6T20	-	-	2T16	1R10-150	1R10-250	
BRC-3555-L7	350	400	150	52	321	220	6T20	-	-	2T16	1R10-150	1R10-250	
BRC-3560-L7	350	450	150	58	353	242	6T20	-	-	2T16	1R10-150	1R10-250	
BRC-3565-L7	350	500	150	63	386	264	6T20	-	-	2T16	1R10-150	1R10-250	
BRC-3570-L7	350	550	150	68	418	286	6T20	-	-	2T16	1R10-150	1R10-250	

Code of Component	Beam Sizes			Final Design				Reinforcement Detail					Shear Links	
	B	H1	H2	UDL	M _{su} & M _{mu}	V	Bar 1 & Bar 4	Bar 2	Bar 3	Bar 5	Link 1	Link 2		
	mm	mm	mm	w kN/m	kNm	kN								
BRC-3575-L7	350	600	150	73	450	308	6T20	2T16	2T16	2T16	1R10-150	1R10-250		
BRC-3580-L7	350	650	150	79	482	330	6T20	2T16	2T16	2T16	1R10-150	1R10-250		
BRC-4045-L7	400	300	150	49	300	206	7T20	-	-	2T20	1R10-100	1R10-200		
BRC-4050-L7	400	350	150	55	337	231	7T20	-	-	2T20	1R10-100	1R10-200		
BRC-4055-L7	400	400	150	61	375	257	7T20	-	-	2T20	1R10-100	1R10-200		
BRC-4060-L7	400	450	150	67	412	283	7T20	-	-	2T20	1R10-100	1R10-200		
BRC-4065-L7	400	500	150	73	450	308	7T20	-	-	2T20	1R10-100	1R10-200		
BRC-4070-L7	400	550	150	80	487	334	7T20	-	-	2T20	1R10-100	1R10-200		
BRC-4075-L7	400	600	150	86	525	360	7T20	2T16	2T16	2T20	1R10-100	1R10-200		
BRC-4080-L7	400	650	150	92	562	386	7T20	2T16	2T16	2T20	1R10-100	1R10-200		

For reinforcement arrangement refer to page 65 - page 66

Table 14

For span L=8m (the data shall applies for span length, L equal or less than 8m subjected to moment and shear capacity required)

Code of Component	Beam Sizes			Final Design			Reinforcement Detail					Shear Links	
	B mm	H1 mm	H2 mm	UDL w kN/m	M _{su} & M _{mu} kNm	V kN	Bar 1 & Bar 4	Bar 2	Bar 3	Bar 5	Link 1	Link 2	
BRC-2055-L8	200	400	150	21	166	100	2T25	-	-	2T12	1R10-250	1R10-250	
BRC-2060-L8	200	450	150	23	183	110	2T25	-	-	2T12	1R10-250	1R10-250	
BRC-2065-L8	200	500	150	25	200	120	2T25	-	-	2T12	1R10-250	1R10-250	
BRC-2070-L8	200	550	150	27	217	130	2T25	-	-	2T12	1R10-250	1R10-250	
BRC-2075-L8	200	600	150	29	233	140	2T25	2T16	2T16	2T12	1R10-250	1R10-250	
BRC-2080-L8	200	650	150	31	250	150	2T25	2T16	2T16	2T12	1R10-250	1R10-250	
BRC-2555-L8	250	400	150	31	251	151	3T25	-	-	2T12	1R10-200	1R10-250	
BRC-2560-L8	250	450	150	35	276	166	3T25	-	-	2T12	1R10-200	1R10-250	
BRC-2565-L8	250	500	150	38	301	181	3T25	-	-	2T16	1R10-200	1R10-250	
BRC-2570-L8	250	550	150	41	326	196	3T25	-	-	2T16	1R10-200	1R10-250	
BRC-2575-L8	250	600	150	44	351	211	3T25	2T16	2T16	2T16	1R10-200	1R10-250	
BRC-2580-L8	250	650	150	47	376	226	3T25	2T16	2T16	2T16	1R10-200	1R10-250	
BRC-3055-L8	300	400	150	42	335	201	4T25	-	-	2T16	1R10-150	1R10-250	
BRC-3060-L8	300	450	150	46	368	221	4T25	-	-	2T16	1R10-150	1R10-250	
BRC-3065-L8	300	500	150	50	402	241	4T25	-	-	2T16	1R10-150	1R10-250	
BRC-3070-L8	300	550	150	54	435	261	4T25	-	-	2T16	1R10-150	1R10-250	
BRC-3075-L8	300	600	150	59	468	281	4T25	2T16	2T16	2T16	1R10-150	1R10-250	
BRC-3080-L8	300	650	150	63	502	301	4T25	2T16	2T16	2T16	1R10-150	1R10-250	
BRC-3555-L8	350	400	150	52	418	251	5T25	-	-	2T16	1R10-100	1R10-200	
BRC-3560-L8	350	450	150	58	460	276	5T25	-	-	2T16	1R10-100	1R10-200	
BRC-3565-L8	350	500	150	63	502	301	5T25	-	-	2T16	1R10-100	1R10-200	
BRC-3570-L8	350	550	150	68	544	326	5T25	-	-	2T16	1R10-100	1R10-200	
BRC-3575-L8	350	600	150	73	586	351	5T25	2T16	2T16	2T16	1R10-100	1R10-200	
BRC-3580-L8	350	650	150	78	627	376	5T25	2T16	2T16	2T16	1R10-100	1R10-200	
BRC-4055-L8	400	400	150	63	502	301	6T25	-	-	2T20	1R10-100	1R10-200	
BRC-4060-L8	400	450	150	69	552	331	6T25	-	-	2T20	1R10-100	1R10-200	
BRC-4065-L8	400	500	150	75	602	361	6T25	-	-	2T20	1R10-100	1R10-200	
BRC-4070-L8	400	550	150	82	653	392	6T25	-	-	2T20	1R10-100	1R10-200	
BRC-4075-L8	400	600	150	88	703	422	6T25	2T16	2T16	2T20	1R10-100	1R10-200	
BRC-4080-L8	400	650	150	94	753	452	6T25	2T16	2T16	2T20	1R10-100	1R10-200	

For reinforcement arrangement refer to page 65 - page 66

Table 15

For span **L=9m** (the data shall applies for span length, L equal or less than 9m subjected to moment and shear capacity required)

Code of Component	Beam Sizes			Final Design			Reinforcement Detail				Shear Links	
	B mm	H1 mm	H2 mm	UDL w kN/m	M _{su} & M _{mu} kNm	V kN	Bar 1 & Bar 4	Bar 2	Bar 3	Bar 5	Link 1	Link 2
BRC-2060-L9	200	450	150	18	183	98	2T25	-	-	2T12	1R10-250	1R10-250
BRC-2065-L9	200	500	150	20	200	107	2T25	-	-	2T12	1R10-250	1R10-250
BRC-2070-L9	200	550	150	21	217	116	2T25	-	-	2T12	1R10-250	1R10-250
BRC-2075-L9	200	600	150	23	233	124	2T25	2T16	2T16	2T12	1R10-250	1R10-250
BRC-2080-L9	200	650	150	25	250	133	2T25	2T16	2T16	2T12	1R10-250	1R10-250
BRC-2560-L9	250	450	150	27	276	147	3T25	-	-	2T12	1R10-200	1R10-250
BRC-2565-L9	250	500	150	30	301	161	3T25	-	-	2T16	1R10-200	1R10-250
BRC-2570-L9	250	550	150	32	326	174	3T25	-	-	2T16	1R10-200	1R10-250
BRC-2575-L9	250	600	150	35	351	187	3T25	2T16	2T16	2T16	1R10-200	1R10-250
BRC-2580-L9	250	650	150	37	376	201	3T25	2T16	2T16	2T16	1R10-200	1R10-250
BRC-3060-L9	300	450	150	36	368	196	4T25	-	-	2T16	1R10-150	1R10-250
BRC-3065-L9	300	500	150	40	402	214	4T25	-	-	2T16	1R10-150	1R10-250
BRC-3070-L9	300	550	150	43	435	232	4T25	-	-	2T16	1R10-150	1R10-250
BRC-3075-L9	300	600	150	46	468	250	4T25	2T16	2T16	2T16	1R10-150	1R10-250
BRC-3080-L9	300	650	150	50	502	268	4T25	2T16	2T16	2T16	1R10-150	1R10-250
BRC-3560-L9	350	450	150	45	460	245	5T25	-	-	2T16	1R10-100	1R10-200
BRC-3565-L9	350	500	150	50	502	268	5T25	-	-	2T16	1R10-100	1R10-200
BRC-3570-L9	350	550	150	54	544	290	5T25	-	-	2T16	1R10-100	1R10-200
BRC-3575-L9	350	600	150	58	586	312	5T25	2T16	2T16	2T16	1R10-100	1R10-200
BRC-3580-L9	350	650	150	62	627	335	5T25	2T16	2T16	2T16	1R10-100	1R10-200
BRC-4060-L9	400	450	150	55	552	294	6T25	-	-	2T20	1R10-100	1R10-200
BRC-4065-L9	400	500	150	59	602	321	6T25	-	-	2T20	1R10-100	1R10-200
BRC-4070-L9	400	550	150	64	653	348	6T25	-	-	2T20	1R10-100	1R10-200
BRC-4075-L9	400	600	150	69	703	375	6T25	2T16	2T16	2T20	1R10-100	1R10-200
BRC-4080-L9	400	650	150	74	753	402	6T25	2T16	2T16	2T20	1R10-100	1R10-200

For reinforcement arrangement refer to page 65 - page 66

Table 16

For span **L=10m** (the data shall applies for span length, L equal or less than 10m subjected to moment and shear capacity required)

Code of Component	Beam Sizes			Final Design			Reinforcement Detail					Shear Links	
	B	H1	H2	UDL	M _{su} & M _{mu}	V	Bar 1 & Bar 4	Bar 2	Bar 3	Bar 5	Link 1	Link 2	
	mm	mm	mm	w kN/m	kNm	kN							
BRC-2070-L10	200	550	150	28	353	169	2T32	-	-	2T12	1R10-200	1R10-250	
BRC-2075-L10	200	600	150	30	381	183	2T32	2T16	2T16	2T12	1R10-200	1R10-250	
BRC-2080-L10	200	650	150	33	408	196	2T32	2T16	2T16	2T12	1R10-200	1R10-250	
BRC-2570-L10	250	550	150	43	534	256	3T32	-	-	2T16	1R10-150	1R10-250	
BRC-2575-L10	250	600	150	46	575	276	3T32	2T16	2T16	2T16	1R10-150	1R10-250	
BRC-2580-L10	250	650	150	49	616	296	3T32	2T16	2T16	2T16	1R10-150	1R10-250	
BRC-3070-L10	300	550	150	43	534	256	3T32	-	-	2T16	1R10-150	1R10-250	
BRC-3075-L10	300	600	150	46	575	276	3T32	2T16	2T16	2T16	1R10-150	1R10-250	
BRC-3080-L10	300	650	150	49	616	296	3T32	2T16	2T16	2T16	1R10-150	1R10-250	
BRC-3570-L10	350	550	150	57	712	342	4T32	-	-	2T16	1R10-100	1R10-200	
BRC-3575-L10	350	600	150	61	766	368	4T32	2T16	2T16	2T16	1R10-100	1R10-200	
BRC-3580-L10	350	650	150	66	821	394	4T32	2T16	2T16	2T16	1R10-100	1R10-200	
BRC-4070-L10	400	550	150	71	890	427	5T32	-	-	2T20	1R10-100	1R10-200	
BRC-4075-L10	400	600	150	77	958	460	5T32	2T16	2T16	2T20	1R10-100	1R10-200	
BRC-4080-L10	400	650	150	82	1027	493	5T32	2T16	2T16	2T20	1R10-100	1R10-200	

For reinforcement arrangement refer to page 65 - page 66





PRECAST COMPONENT

- A. PRECAST RECTANGULAR BEAM (SIMPLY SUPPORTED)
- B. PRECAST RECTANGULAR BEAM (CONTINUOUS BEAM)
- C. PRECAST INVERTED T BEAM (CONTINUOUS BEAM)**
- D. PRECAST EDGE BEAM (CONTINUOUS BEAM)
- E. PRECAST SQUARE COLUMN
- F. PRECAST RECTANGULAR COLUMN
- G. PRECAST HALF SLAB (CONTINUOUS SUPPORTED)
- H. PRECAST HOLLOWCORE SLAB
- I. PRECAST PRESTRESSED PLANK
- J. PRECAST WALL (LOAD BEARING)
- K. PRECAST WALL (NON-LOAD BEARING)
- L. PRECAST STAIRCASE
- M. PRECAST CORBEL CONNECTION
- N. PRECAST COLUMN NIB CONNECTION
- O. PRECAST HALF JOINT CONNECTION
- P. WET JOINT CONNECTION

NOTES

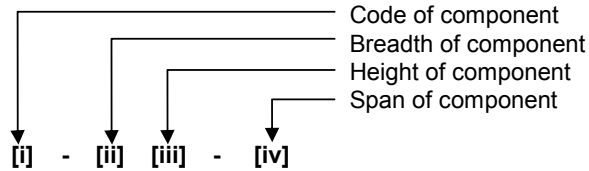

[i] Types of Component

Code	Component
BTC	Precast inverted T beam (continuous beam)

[ii] Breadth of Component

Depends on component range

[iii] Height of Component

Depends on component range

[iv] Span of Component

Depends on span of the component

Notation

M_{mi} = Maximum moment capacity at mid span during installation stage

V_i = Maximum shear capacity during installation stage

w_i = Uniformly distributed load during installation stage

M_{mf} = Maximum moment capacity at mid span during final stage

M_{sf} = Maximum moment capacity at support during final stage

V_f = Maximum shear capacity during final stage

w_f = Uniformly distributed ultimate load during final stage

PRECAST BEAM – INVERTED T BEAM (CONTINUOUS BEAM)

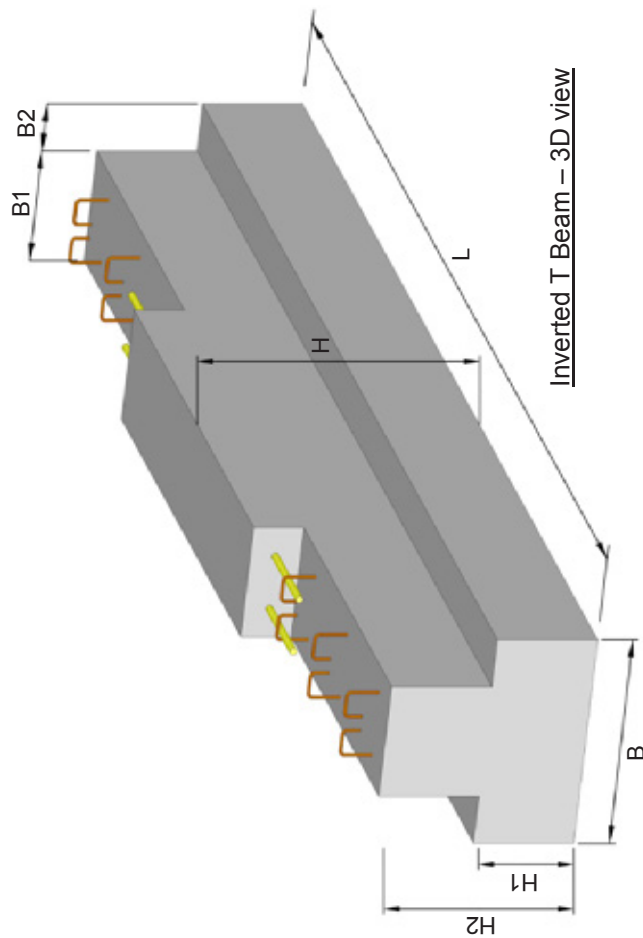

Inverted T Beam – 3D view

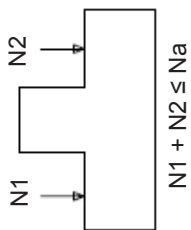

Figure 34. $N_1 + N_2 \leq N_a$ for Inverted T

Nib schedule

Nib Section		Link 1	Max. Allowable Ultimate Axial Load, N_a (kN/m) (see Figure 34)
B2	H1		
mm	mm		
125	300 to 500	T10-300	110
125	300 to 500	T10-250	135
125	300 to 500	T10-200	165
125	300 to 500	T10-150	225

H1 = In order to choose nib link 1, ultimate axial load due to selfweight of precast slab, slab topping, superimposed dead load and live load must be calculated.

Lap and anchorage schedule

Reinforcement Bar Size (mm)	Lap and Anchorage Length (mm)
12	500
16	650
20	800
25	1000
32	1300

CODE OF COMPONENTS

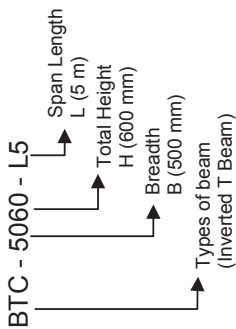

Specification

- Minimum concrete grade C35 (Precast and cast in-situ concrete) at final stage design.
- Minimum concrete compressive strength of 15 N/mm² for first lifting.
- The position of lifting hook at distance of 0.2L from end of beam and to be advised and checked by competent person.
- Minimum concrete compressive strength of 25 N/mm² for installation stage.
- Concrete cover to main reinforcement = 35mm.
- Fire resistance = 2 hours.
- Characteristic of steel reinforcement
High tensile (T) $f_y = 460$ N/mm²
Mild steel (R) $f_y = 250$ N/mm²
- The beam is designed as simply supported beam during installation stage (unprop) and continuous beam during final stage
- The hogging moment resistance at the support is provided by in-situ placed bar 5.
- Load should be uniformly distributed.
- The application of concentrated load area on precast element shall be referred to competent person.
- Concrete infill (beam top and slab topping) are one stage casting.
- M_{inf} and M_{sl} values and shear shall refer to BS 8110 Part 1 cl. 3.4.3 and Table 3.6.
- The connection system between precast component and cast in-situ structure shall be referred to competent person.
- The design has been prepared in accordance with the BS 8110 (1997).

PRECAST BEAM – INVERTED T BEAM (CONTINUOUS BEAM) DETAILS

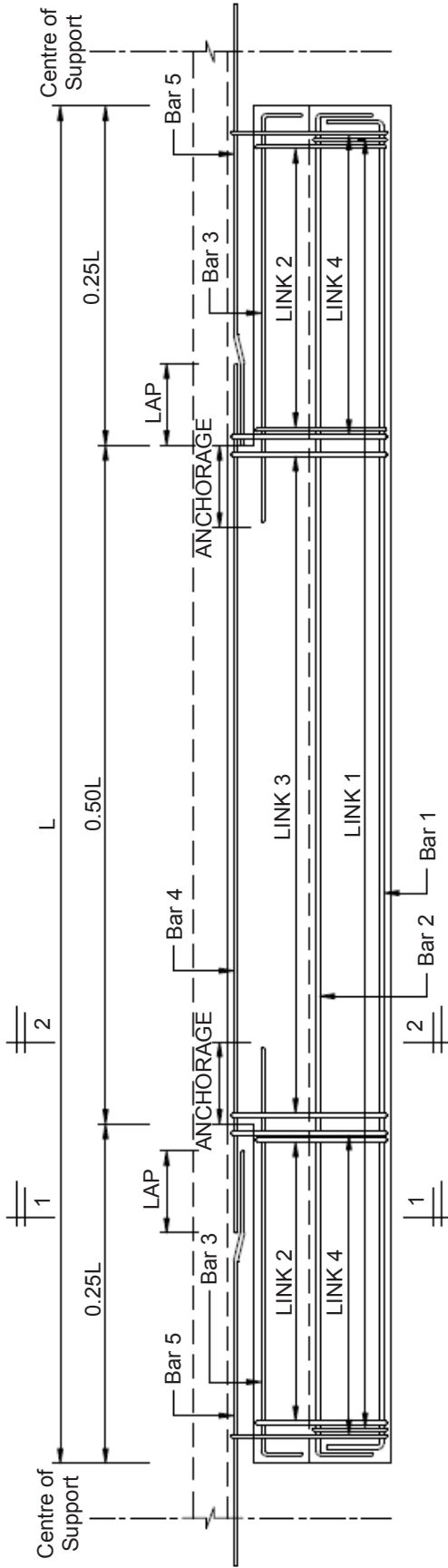

Elevation
Reinforcement arrangement

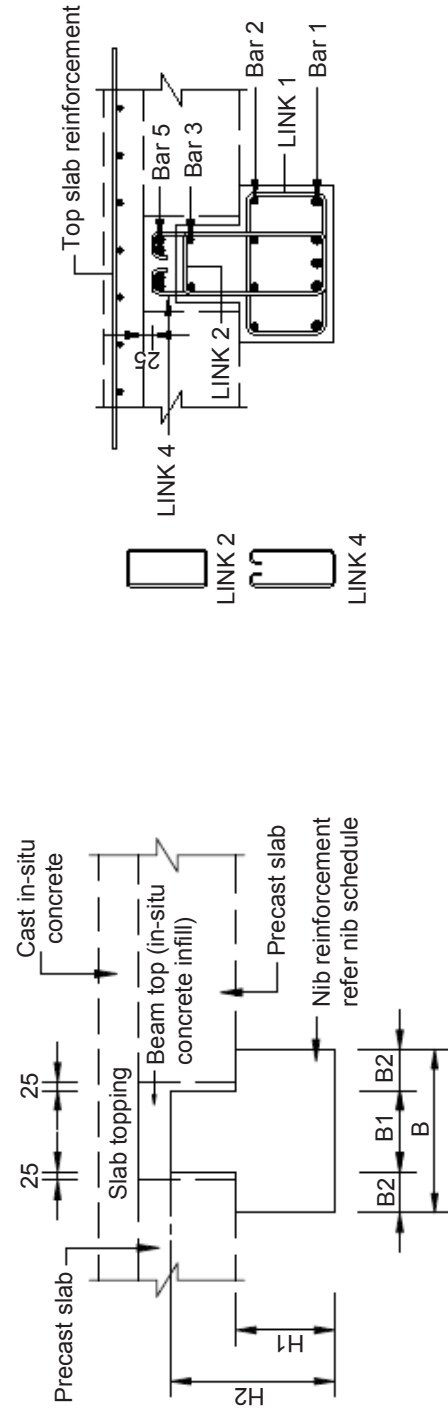

Cross section 1-1

PRECAST BEAM – INVERTED T BEAM (CONTINUOUS BEAM) DETAILS

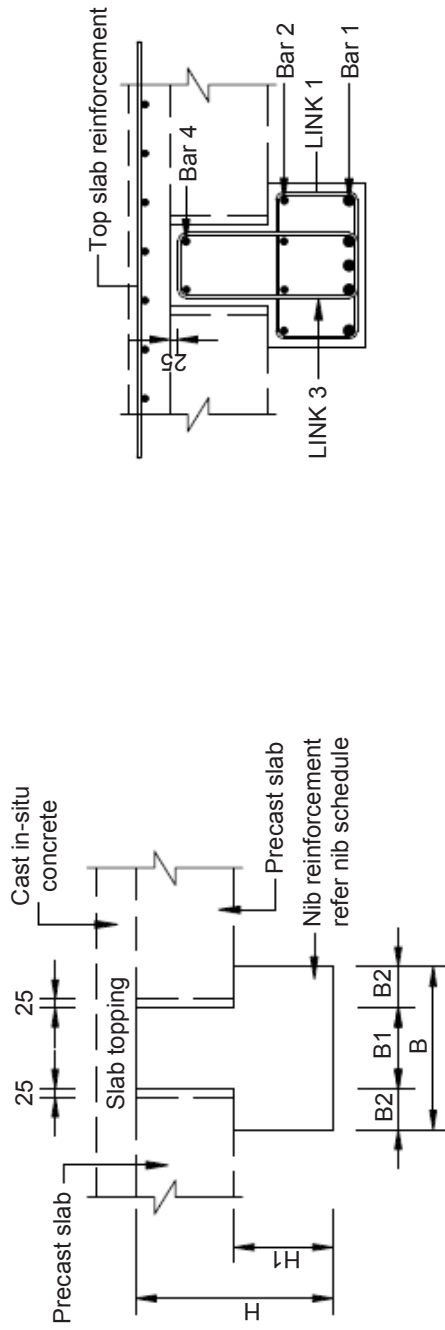

Cross section 2-2

Table 17

For span L=5m (the data shall applies for span length, L equal or less than 5m subjected to moment and shear capacity required)

Code of Component	Beam Sizes			Installation Design			Final Design			Reinforcement Detail					Shear Links					
	B	B1	H	H2	UDL	M _{mi.}	V _i	UDL	M _{sf.}	M _{mf.}	V _f	Bar 1	Bar 2	Bar 3	Bar 4	Bar 5	Link 2	Link 3	Link 4	
	mm	mm	mm	mm	w _i kN/m	kN/m	kN	w _f kN/m	kN/m	kN/m	kN/m									
BTC-5060-L5	500	250	600	500	60	190	152	84	184	190	253	5T16	4T10	2T10	2T16	2T25	T10-300	T10-200	2T10-250	
BTC-5070-L5	500	250	700	500	71	224	179	99	217	224	299	5T16	4T10	2T10	2T16	2T25	T10-250	T10-200	2T10-250	
BTC-6060-L5	600	350	600	500	73	228	183	101	237	228	304	6T16	4T10	2T10	2T20	4T20	T10-300	T10-150	2T10-200	
BTC-6070-L5	600	350	700	500	86	269	215	119	279	269	359	6T16	4T10	2T10	2T20	4T20	T10-250	T10-150	2T10-200	
BTC-6560-L5	650	400	600	500	85	266	213	118	260	266	355	7T16	4T10	2T10	2T20	2T25 + 2T16	T10-250	T10-100	2T10-200	
BTC-6570-L5	650	400	700	500	100	314	251	139	307	314	419	7T16	4T10	2T10	2T20	2T25 + 2T16	T10-200	T10-100	2T12-200	
BTC-7060-L5	700	450	600	500	97	304	243	135	300	304	406	8T16	4T10	2T10	2T20	2T32	T12-300	T12-250	2T12-250	
BTC-7070-L5	700	450	700	500	114	359	287	159	354	359	478	8T16	4T10	2T10	2T20	2T32	T12-250	T12-250	2T12-250	
BTC-7560-L5	750	500	600	500	109	342	274	152	355	342	456	9T16	4T10	2T10	2T25	6T20	T12-300	T12-200	2T12-200	
BTC-7570-L5	750	500	700	500	129	404	323	179	419	404	538	9T16	4T10	2T10	2T25	6T20	T12-200	T12-200	2T12-250	
BTC-8060-L5	800	550	600	500	121	380	304	169	417	380	507	10T16	4T10	2T10	2T25	2T32 + 2T20	T12-150	T12-200	2T12-200	
BTC-8070-L5	800	550	700	500	143	448	359	199	493	448	598	10T16	4T10	2T10	2T25	2T32 + 2T20	T12-200	T12-200	2T12-200	

For reinforcement arrangement refer to page 83 – page 85

Table 18

For span **L=7m** (the data shall applies for span length, L equal or less than 7m subjected to moment and shear capacity required)

Code of Component	Beam Sizes			Installation Design			Final Design			Reinforcement Detail					Shear Links					
	B	B1	H	H2	UDL	M _{ini.}	V _i	UDL	M _{sf.}	M _{inf.}	V _f	Bar 1	Bar 2	Bar 3	Bar 4	Bar 5	Link 2	Link 3	Link 4	
	mm	mm	mm	mm	w _i kN/m	kN/m	kN	w _f kN/m	kN/m	kN/m	kN/m									
BTC-5060-L7	500	250	600	500	48	296	169	67	300	296	282	5T20	4T10	2T10	2T16	2T32	T10-300	T10-200	2T10-200	
BTC-5070-L7	500	250	700	500	57	349	200	79	354	349	333	5T20	4T10	2T10	2T16	2T32	T10-250	T10-200	2T10-200	
BTC-6060-L7	600	350	600	500	57	355	203	80	368	355	338	6T20	4T10	2T10	2T20	4T25	T10-300	T10-150	2T10-200	
BTC-6070-L7	600	350	700	500	68	419	240	95	435	419	399	6T20	4T10	2T10	2T20	4T25	T10-200	T10-150	2T10-200	
BTC-6560-L7	650	400	600	500	67	414	237	94	417	414	395	7T20	4T10	2T10	2T20	2T32 + 2T20	T10-250	T10-100	2T10-150	
BTC-6570-L7	650	400	700	500	79	489	279	110	493	489	466	7T20	4T10	2T10	2T20	2T32 + 2T20	T10-150	T10-100	2T12-150	
BTC-7060-L7	700	450	600	500	77	474	271	107	483	474	451	8T20	4T10	2T10	2T20	2T32 + 2T25	T12-300	T12-250	2T12-250	
BTC-7070-L7	700	450	700	500	91	559	319	126	571	559	532	8T20	4T10	2T10	2T20	2T32 + 2T25	T12-225	T12-250	2T12-250	
BTC-7560-L7	750	500	600	500	86	533	304	120	552	533	507	9T20	4T10	2T10	2T25	6T25	T12-250	T12-200	2T12-150	
BTC-7570-L7	750	500	700	500	102	629	359	142	652	629	599	9T20	4T10	2T10	2T25	6T25	T12-200	T12-200	2T12-200	
BTC-8060-L7	800	550	600	500	96	592	338	134	600	592	564	10T20	4T10	2T10	2T25	4T32	T12-250	T12-200	2T12-200	
BTC-8070-L7	800	550	700	500	114	699	399	158	709	699	665	10T20	4T10	2T10	2T25	4T32	T12-150	T12-200	2T12-200	

For reinforcement arrangement refer to page 83 – page 85

Table 19

For span L=9m (the data shall applies for span length, L equal or less than 9m subjected to moment and shear capacity required)

Code of Component	Beam Sizes			Installation Design			Final Design			Reinforcement Detail					Shear Links					
	B	B1	H	H2	UDL	M _{mi.}	V _i	UDL	M _{sf.}	M _{mf.}	V _f	Bar 1	Bar 2	Bar 3	Bar 4	Bar 5	Link 2	Link 3	Link 4	
	mm	mm	mm	mm	w _i kN/m	kN/m	kN	w _f kN/m	kN/m	kN/m	kN/m									
BTC-5060-L9	500	250	600	500	41	417	185	57	483	417	309	5T25	4T10	2T10	2T16	2T32 + 2T25	T10-300	T10-200	2T10-200	
BTC-5070-L9	500	250	700	500	53	544	242	74	571	544	402	5T25	4T10	2T10	2T16	2T32 + 2T25	T10-200	T10-200	2T10-200	
BTC-6060-L9	600	350	600	500	54	550	246	75	600	552	409	6T25	4T10	2T10	2T20	4T32	T10-250	T10-150	2T10-150	
BTC-6070-L9	600	350	700	500	63	652	290	89	709	652	483	6T25	4T10	2T10	2T20	4T32	T10-150	T10-150	2T10-150	
BTC-6560-L9	650	400	600	500	63	645	286	88	600	645	477	7T25	4T10	2T10	2T20	4T32	T10-200	T10-100	2T10-150	
BTC-6570-L9	650	400	700	500	75	761	338	104	709	761	564	7T25	4T10	2T10	2T20	4T32	T10-150	T10-100	2T12-100	
BTC-7060-L9	700	450	600	500	72	737	327	101	779	737	546	8T25	4T10	2T10	2T20	4T32 + 2T25	T12-250	T12-250	2T12-200	
BTC-7070-L9	700	450	700	500	85	870	387	119	922	870	644	8T25	4T10	2T10	2T20	4T32 + 2T25	T12-175	T12-250	2T12-200	
BTC-7560-L9	750	500	600	500	81	829	368	113	899	829	614	9T25	4T10	2T10	2T25	6T32	T12-200	T12-200	2T12-150	
BTC-7570-L9	750	500	700	500	96	979	435	134	1063	979	725	9T25	4T10	2T10	2T25	6T32	T12-150	T12-200	2T12-150	
BTC-8060-L9	800	550	600	500	90	917	407	125	899	917	679	10T25	4T10	2T10	2T25	6T32	T12-200	T12-200	2T12-150	
BTC-8070-L9	800	550	700	500	107	1087	483	149	1063	1087	805	10T25	4T10	2T10	2T25	6T32	T12-150	T12-200	2T12-150	

For reinforcement arrangement refer to page 83 – page 85



PRECAST COMPONENT

- A. PRECAST RECTANGULAR BEAM (SIMPLY SUPPORTED)
- B. PRECAST RECTANGULAR BEAM (CONTINUOUS BEAM)
- C. PRECAST INVERTED T BEAM (CONTINUOUS BEAM)
- D. PRECAST EDGE BEAM (CONTINUOUS BEAM)**
- E. PRECAST SQUARE COLUMN
- F. PRECAST RECTANGULAR COLUMN
- G. PRECAST HALF SLAB (CONTINUOUS SUPPORTED)
- H. PRECAST HOLLOWCORE SLAB
- I. PRECAST PRESTRESSED PLANK
- J. PRECAST WALL (LOAD BEARING)
- K. PRECAST WALL (NON-LOAD BEARING)
- L. PRECAST STAIRCASE
- M. PRECAST CORBEL CONNECTION
- N. PRECAST COLUMN NIB CONNECTION
- O. PRECAST HALF JOINT CONNECTION
- P. WET JOINT CONNECTION

NOTES

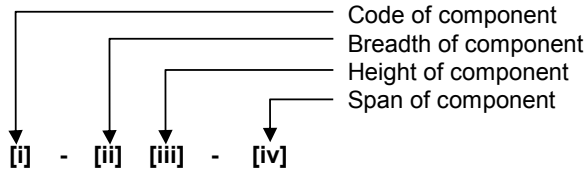

[i] Types of Component

Code	Component
BLC	Precast edge beam -L shape (continuous beam)

[ii] Breadth of Component

Depends on component range

[iii] Height of Component

Depends on component range

[iv] Span of Component

Depends on span of the component

Notation

- M_{mi} = Maximum moment capacity at mid span during installation stage
- V_i = Maximum shear capacity during installation stage
- w_i = Uniformly distributed load during installation stage
- M_{mf} = Maximum moment capacity at mid span during final stage
- M_{sf} = Maximum moment capacity at support during final stage
- V_f = Maximum shear capacity during final stage
- w_f = Uniformly distributed ultimate load during final stage

PRECAST BEAM – EDGE BEAM (CONTINUOUS BEAM)

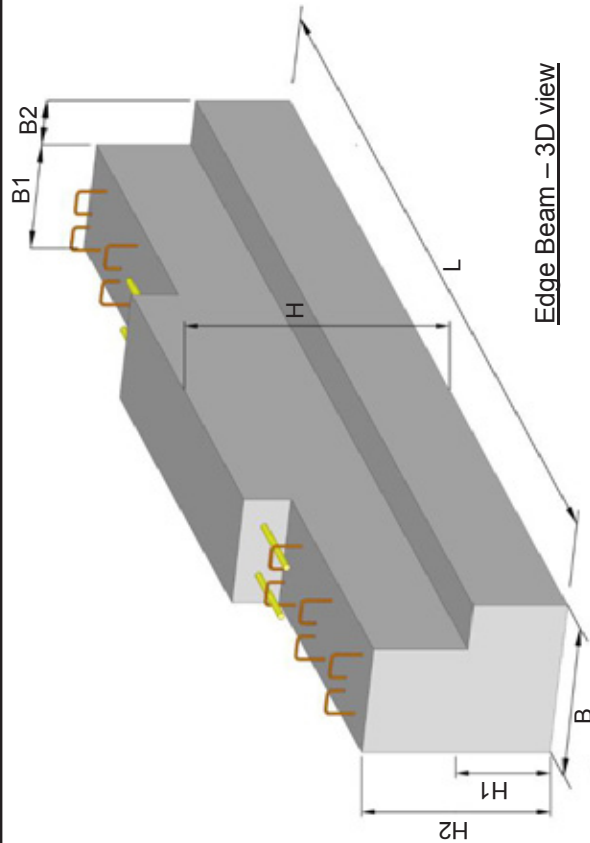

Edge Beam – 3D view

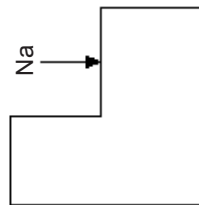

Figure 35. Na for Edge Beam

Nib schedule

Nib Section		Link 1	Max. Allowable Ultimate Axial Load, Na (kN/m) (see Figure 35)
B2	H1		
150	300 to 500	T10-300	110
150	300 to 500	T10-250	135
150	300 to 500	T10-200	165
150	300 to 500	T10-150	225

H1 = Varies with min 300mm and max 500mm or it can be used more than 500mm to suit with precast slab.
 In order to choose nib link 1, ultimate axial load due to selfweight of precast slab, slab topping, superimposed dead load and live load must be calculated.

Lap and anchorage schedule

Reinforcement Bar Size (mm)	Lap and Anchorage Length (mm)
12	500
16	650
20	800
25	1000
32	1300

CODE OF COMPONENTS

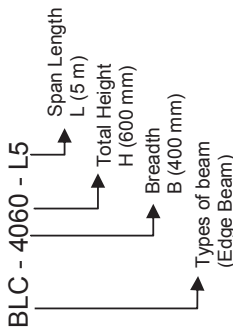

Specification

- Minimum concrete grade C35 (Precast and cast in-situ concrete) at final stage design.
- Minimum concrete compressive strength of 15 N/mm² for first lifting.
- The position of lifting hook at distance of 0.2L from end of beam and to be advised and checked by competent person.
- Minimum concrete compressive strength of 25 N/mm² for installation stage.
- Concrete cover to main reinforcement = 35mm.
- Fire resistance = 2 hours.
- Characteristic of steel reinforcement
- Mild steel (R) fy = 460 N/mm²
Mild steel (R) fw = 250 N/mm²
- The beam is designed as simply supported beam during installation stage (unprop) and continuous beam during final stage.
- The hogging moment resistance at the support is provided by in-situ placed bar 5.
- Load should be uniformly distributed.
- The application of concentrated load area on precast element shall be referred to competent person.
- Concrete infill (beam top and slab topping) are one stage casting.
- M_{min} and M_{cr} values and shear shall refer to BS 8110 Part 1 cl. 3.4.3 and Table 3.6.
- The connection system between precast component and cast in-situ structure shall be referred to competent person.
- The design has been prepared in accordance with BS 8110 (1997).

PRECAST BEAM – EDGE BEAM (CONTINUOUS BEAM) DETAILS

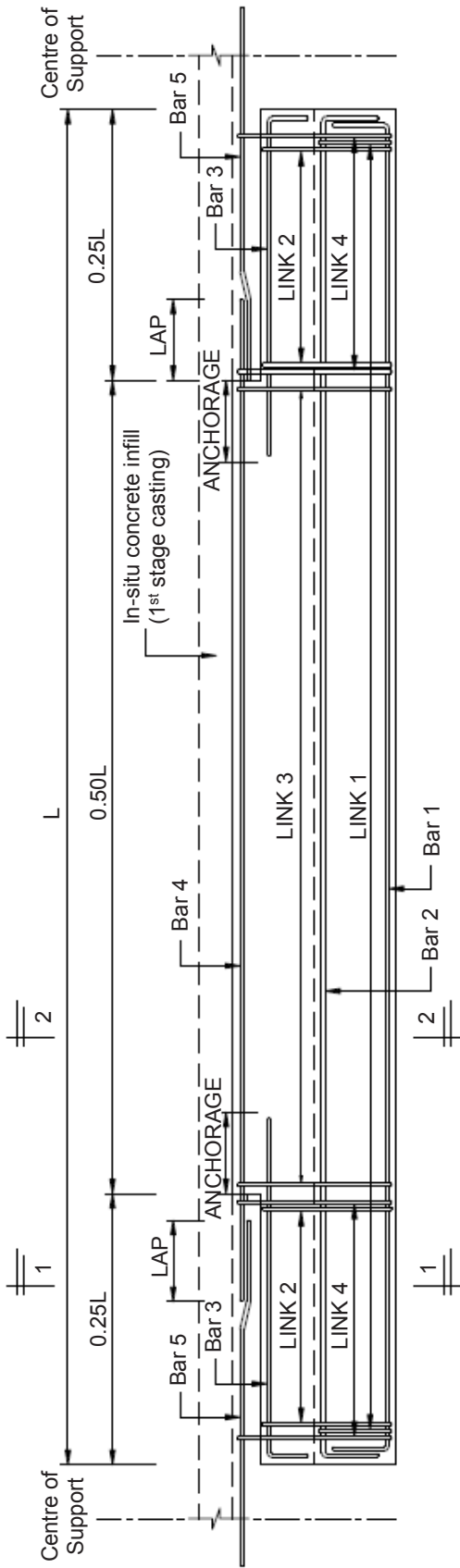

Elevation
Reinforcement arrangement

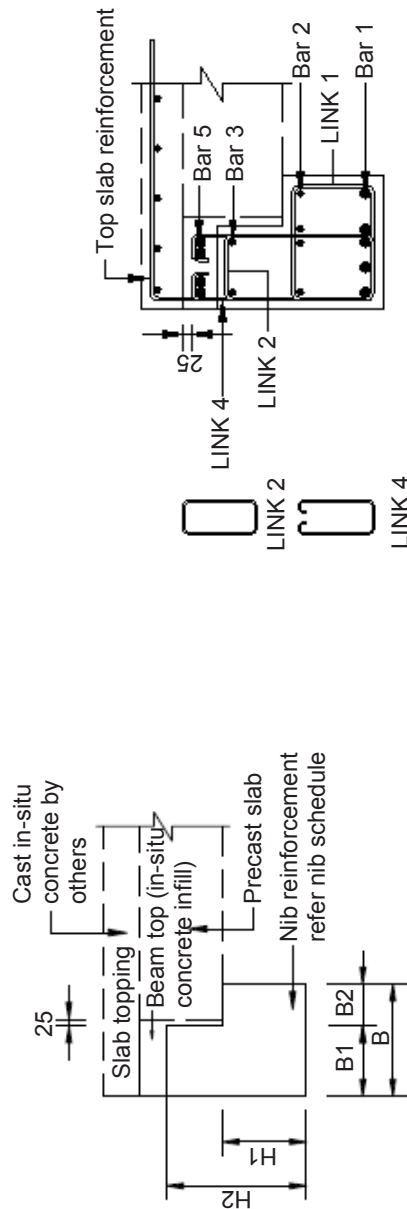

Cross section 1-1

PRECAST BEAM – EDGE BEAM (CONTINUOUS BEAM) DETAILS

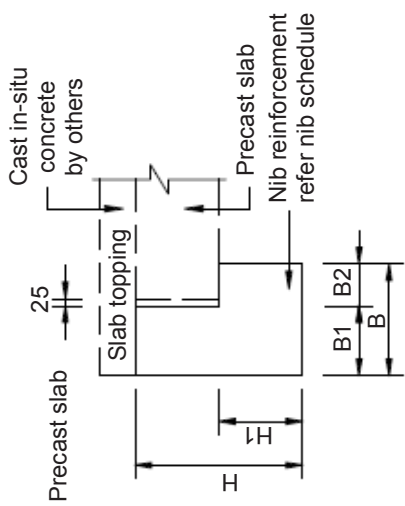
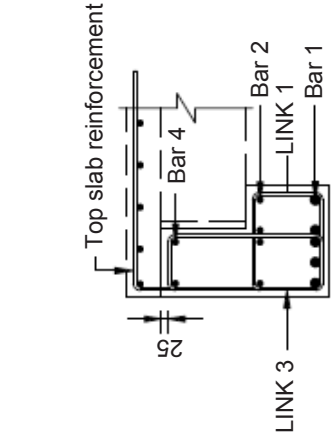

Cross section 2-2

Table 20

For span L=5m (the data shall applies for span length, L equal or less than 5m subjected to moment and shear capacity required)

Code of Component	Beam Sizes		Installation Design			Final Design			Reinforcement Detail					Shear Links						
	B	B1	H	H2	UDL	M _{mi.}	V _i	UDL	M _{sf.}	M _{mf.}	V _f	Bar 1	Bar 2	Bar 3	Bar 4	Bar 5	Link 2	Link 3	Link 4	
	mm	mm	mm	mm	w _i kN/m	kN/m	kN	w _f kN/m	kN/m	kN/m	kN/m									
BLC-4060-L5	400	250	600	500	60	190	152	84	184	190	253	5T16	4T10	2T10	2T16	2T25	T10-300	T10-200	2T10-150	
BLC-4070-L5	400	250	700	500	71	224	179	99	217	224	299	5T16	4T10	2T10	2T16	2T25	T10-250	T10-200	2T10-150	
BLC-5060-L5	500	350	600	500	73	228	183	101	237	228	304	6T16	4T10	2T10	2T20	4T20	T10-300	T10-150	2T10-150	
BLC-5070-L5	500	350	700	500	86	269	215	119	279	269	359	6T16	4T10	2T10	2T20	4T20	T10-250	T10-150	2T10-150	
BLC-5560-L5	550	400	600	500	85	266	213	118	260	266	355	7T16	4T10	2T10	2T20	2T25 + 2T16	T10-250	T10-100	2T10-200	
BLC-5570-L5	550	400	700	500	100	314	251	139	307	314	419	7T16	4T10	2T10	2T20	2T25 + 2T16	T12-200	T10-100	2T10-200	
BLC-6060-L5	600	450	600	500	97	304	243	135	300	304	406	8T16	4T10	2T10	2T20	2T32	T12-300	T12-250	2T12-250	
BLC-6070-L5	600	450	700	500	114	359	287	159	354	359	478	8T16	4T10	2T10	2T20	2T32	T12-250	T12-250	2T12-250	
BLC-6560-L5	650	500	600	500	109	342	274	152	355	342	456	9T16	4T10	2T10	2T25	6T20	T12-300	T12-200	2T12-200	
BLC-6570-L5	650	500	700	500	129	404	323	179	419	404	538	9T16	4T10	2T10	2T25	6T20	T12-200	T12-200	2T12-250	
BLC-7060-L5	700	550	600	500	121	380	304	169	417	380	507	10T16	4T10	2T10	2T25	2T32 + 2T20	T12-150	T12-200	2T12-200	
BLC-7070-L5	700	550	700	500	143	448	359	199	493	448	598	10T16	4T10	2T10	2T25	2T32 + 2T20	T12-200	T12-200	2T12-200	

For reinforcement arrangement refer to page 91 – page 93

Table 21

For span **L=7m** (the data shall applies for span length, L equal or less than 7m subjected to moment and shear capacity required)

Code of Component	Beam Sizes			Installation Design				Final Design			Reinforcement Detail					Shear Links			
	B	B1	H	H2	UDL	M _{ini.}	V _i	UDL	M _{sf.}	M _{inf.}	V _f	Bar 1	Bar 2	Bar 3	Bar 4	Bar 5	Link 2	Link 3	Link 4
	mm	mm	mm	mm	w _i kN/m	kN/m	kN	w _f kN/m	kN/m	kN/m	kN/m								
BLC-4060-L7	400	250	600	500	48	296	169	67	300	296	282	5T20	4T10	2T10	2T16	2T32	T10-300	T10-200	2T10-150
BLC-4070-L7	400	250	700	500	57	349	200	79	354	349	333	5T20	4T10	2T10	2T16	2T32	T10-250	T10-200	2T10-150
BLC-5060-L7	500	350	600	500	57	355	203	80	368	355	338	6T20	4T10	2T10	2T20	4T25	T10-300	T10-150	2T10-150
BLC-5070-L7	500	350	700	500	68	419	240	95	435	419	399	6T20	4T10	2T10	2T20	4T25	T10-200	T10-150	2T10-150
BLC-5560-L7	550	400	600	500	67	414	237	94	417	414	395	7T20	4T10	2T10	2T20	2T32 + 2T20	T10-250	T10-100	2T10-150
BLC-5570-L7	550	400	700	500	79	489	279	110	493	489	466	7T20	4T10	2T10	2T20	2T32 + 2T20	T12-200	T12-100	2T10-150
BLC-6060-L7	600	450	600	500	77	474	271	107	483	474	451	8T20	4T10	2T10	2T20	2T32 + 2T25	T12-300	T12-250	2T12-250
BLC-6070-L7	600	450	700	500	91	559	319	126	571	559	532	8T20	4T10	2T10	2T20	2T32 + 2T25	T12-200	T12-250	2T12-250
BLC-6560-L7	650	500	600	500	86	533	304	120	552	533	507	9T20	4T10	2T10	2T25	6T25	T12-250	T12-150	2T12-150
BLC-6570-L7	650	500	700	500	102	629	359	142	652	629	599	9T20	4T10	2T10	2T25	6T25	T12-200	T12-150	2T12-200
BLC-7060-L7	700	550	600	500	96	592	338	134	600	592	564	10T20	4T10	2T10	2T25	2T32 + 2T32	T12-250	T12-200	2T12-200
BLC-7070-L7	700	550	700	500	114	699	399	158	709	699	665	10T20	4T10	2T10	2T25	2T32 + 2T32	T12-150	T12-200	2T12-200

For reinforcement arrangement refer to page 91 – page 93

Table 22

For span L=9m (the data shall applies for span length, L equal or less than 9m subjected to moment and shear capacity required)

Code of Component	Beam Sizes		Installation Design			Final Design			Reinforcement Detail					Shear Links						
	B	B1	H	H2	UDL	M _{mi.}	V _i	UDL	M _{sf.}	M _{mf.}	V _f	Bar 1	Bar 2	Bar 3	Bar 4	Bar 5	Link 2	Link 3	Link 4	
	mm	mm	mm	mm	w _i kN/m	kN/m	kN	w _f kN/m	kN/m	kN/m	kN/m									
BLC-4060-L9	400	250	600	500	41	417	185	57	483	417	309	5T25	4T10	2T10	2T16	2T32 + 2T25	T10-300	T10-200	2T10-200	
BLC-4070-L9	400	250	700	500	53	544	242	74	571	544	402	5T25	4T10	2T10	2T16	2T32 + 2T25	T10-200	T10-200	2T10-200	
BLC-5060-L9	500	350	600	500	54	552	246	75	600	552	409	6T25	4T10	2T10	2T20	4T32	T10-250	T10-150	2T10-150	
BLC-5070-L9	500	350	700	500	64	652	290	89	709	652	483	6T25	4T10	2T10	2T20	4T32	T10-150	T10-150	2T10-150	
BLC-5560-L9	550	400	600	500	63	645	286	88	600	645	477	7T25	4T10	2T10	2T20	4T32	T10-200	T10-100	2T10-150	
BLC-5570-L9	550	400	700	500	75	761	338	104	709	761	564	7T25	4T10	2T10	2T20	4T32	T10-150	T10-100	2T10-100	
BLC-6060-L9	600	450	600	500	72	737	327	101	779	737	546	8T25	4T10	2T10	2T20	4T32 + 2T25	T12-250	T12-250	2T12-200	
BLC-6070-L9	600	450	700	500	85	870	387	119	922	870	644	8T25	4T10	2T10	2T20	4T32 + 2T25	T12-175	T12-250	2T12-200	
BLC-6560-L9	650	500	600	500	81	829	368	113	899	829	614	9T25	4T10	2T10	2T25	6T32	T12-200	T12-200	2T12-150	
BLC-6570-L9	650	500	700	500	96	979	435	134	1063	979	725	9T25	4T10	2T10	2T25	6T32	T12-150	T12-200	2T12-150	
BLC-7060-L9	700	550	600	500	90	917	407	125	899	917	679	10T25	4T10	2T10	2T25	6T32	T12-200	T12-200	2T12-150	
BLC-7070-L9	700	550	700	500	107	1087	483	149	1063	1087	805	10T25	4T10	2T10	2T25	6T32	T12-150	T12-200	2T12-150	

For reinforcement arrangement refer to page 91 – page 93



PRECAST COMPONENT

- A. PRECAST RECTANGULAR BEAM (SIMPLY SUPPORTED)
- B. PRECAST RECTANGULAR BEAM (CONTINUOUS BEAM)
- C. PRECAST INVERTED T BEAM (CONTINUOUS BEAM)
- D. PRECAST EDGE BEAM (CONTINUOUS BEAM)
- E. PRECAST SQUARE COLUMN**
- F. PRECAST RECTANGULAR COLUMN
- G. PRECAST HALF SLAB (CONTINUOUS SUPPORTED)
- H. PRECAST HOLLOWCORE SLAB
- I. PRECAST PRESTRESSED PLANK
- J. PRECAST WALL (LOAD BEARING)
- K. PRECAST WALL (NON-LOAD BEARING)
- L. PRECAST STAIRCASE
- M. PRECAST CORBEL CONNECTION
- N. PRECAST COLUMN NIB CONNECTION
- O. PRECAST HALF JOINT CONNECTION
- P. WET JOINT CONNECTION

NOTES

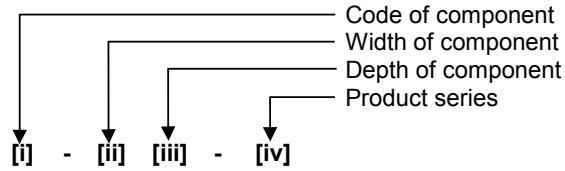

[i] Types of Component

Code	Component
CS	Precast square column

[ii] Width of Component

Depends on component range

[iii] Depth of Component

Depends on component range

[iv] Product Series

Depends maximum axial load of component

Notation

- M_{xi} = Maximum moment capacity during installation stage design in x direction
- M_{yi} = Maximum moment capacity during installation stage design in y direction
- N_i = Maximum axial load during installation stage design
- M_{xf} = Maximum moment capacity during final stage design in x direction
- M_{yf} = Maximum moment capacity during final stage design in y direction
- N_f = Maximum axial load during final stage design

PRECAST SQUARE COLUMN

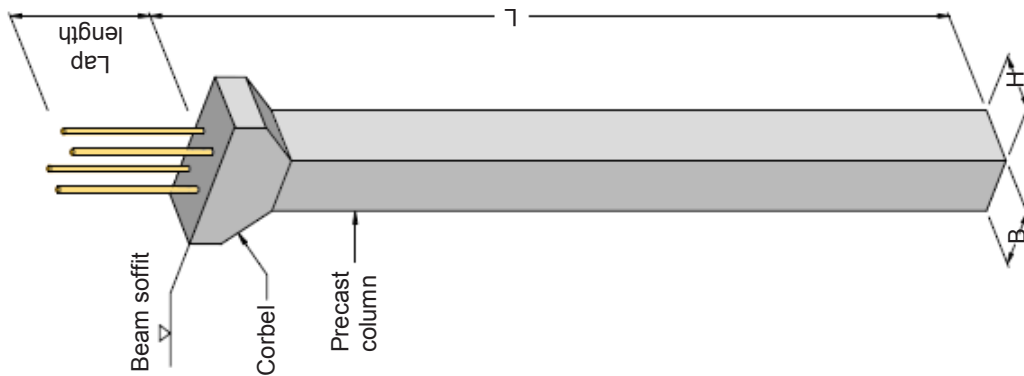

Typical column
Single Tier (3D view)

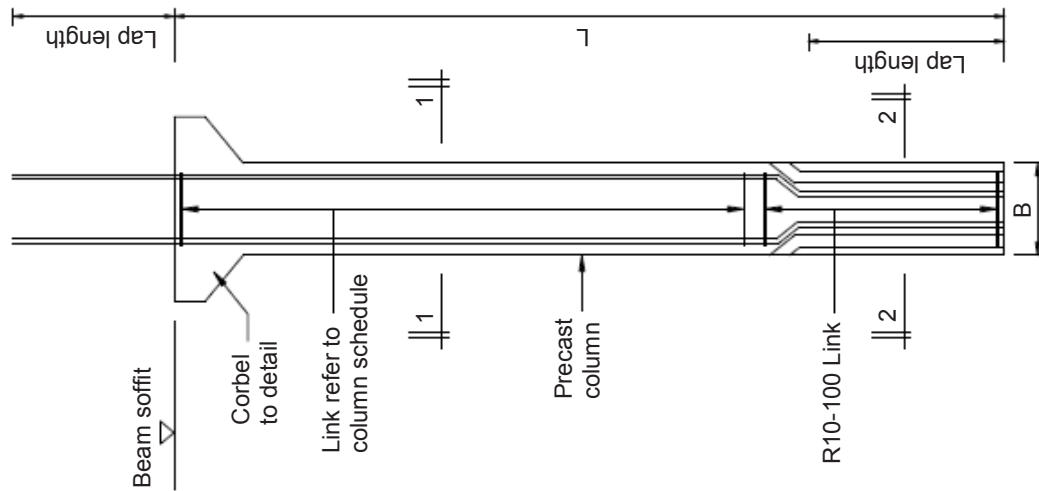

Typical column
(Elevation-Single Tier)

Lap schedule

Reinforcement Bar Size (mm)	Lap Length (mm)
12	500
16	650
20	800
25	1000
32	1300

CODE OF COMPONENTS

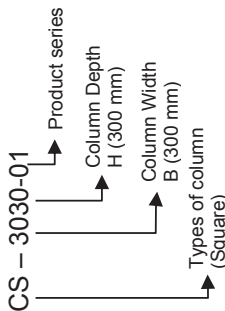

Specification

Installation Stage design

- Bottom end shall be design as condition 1 whereas top end shall be designed as condition 4 (i.e. free cantilever), as per BS 8110 Part 1 cl. 3.8.1.6.2.
- Minimum concrete grade C25.
- Madd = $(N_h/2000) \sqrt{f_{ck}}$ K in BS 8110 Part 1 cl. 3.8.3.1 shall be computed by user and Madd shall be smaller than Mint

PRECAST SQUARE COLUMN

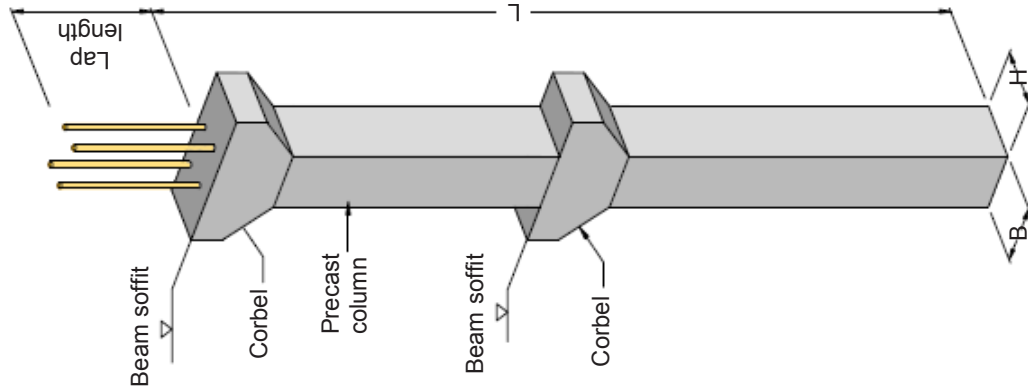

Typical column
Double Tier (3D view)

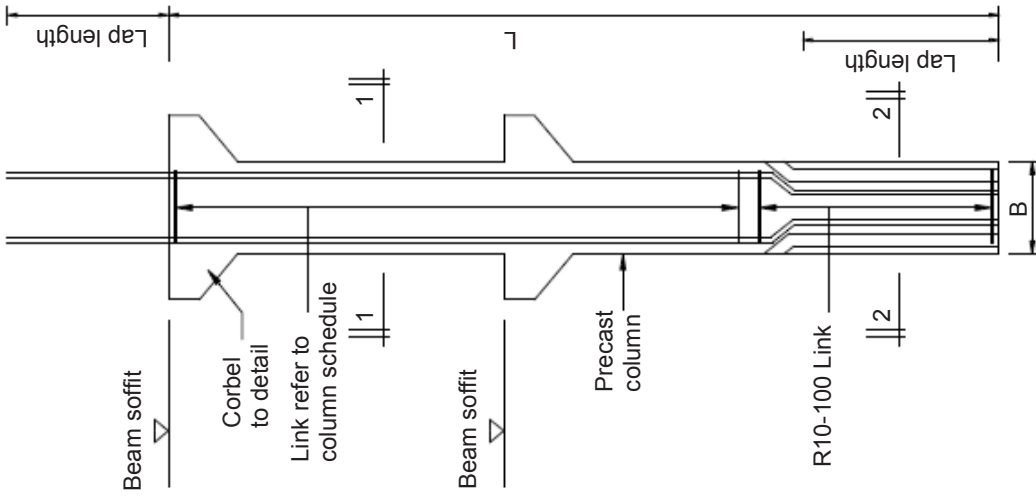

Typical column
(Elevation-Double Tier)

Lap schedule

Reinforcement Bar Size (mm)	Lap Length (mm)
12	500
16	650
20	800
25	1000
32	1300

Specification

Final Stage Design

- Resultant of design moment (M) in consideration of M_x , M_y , M_i , M_{min} and M_{add} shall be computed by users.
- Ultimate force due to selfweight of precast beam, precast slab, beam top concrete infill, slab topping, superimposed dead load and live load shall be computed by user and total load shall be smaller than N_f .
- All end condition shall be designed as condition as per BS 8110 Part 1: 1997 cl. 3.8.1.6.2.
- Minimum concrete grade C35 (Precast and cast in-situ concrete).
- All design is compliance with BS 8110 Part 1:1997 and BS 8110 Part 3:1985
- For the design of ultimate moment capacity, main bar position is considered 110mm from column face to main bar centre.
- Minimum concrete grade C25 for initial stage design.
- Concrete cover to main reinforcement = 40mm.
- Fire resistance = 2 hours.
- Characteristic of steel reinforcement
High tensile (T) $f_y = 460 \text{ N/mm}^2$
Mild steel (R) $f_{yv} = 250 \text{ N/mm}^2$
- In order to control crack due to bending in column, ultimate axial load at final stage must be greater than $0.2f_{cu}Ac$
- If ultimate axial load is smaller than $0.2f_{cu}Ac$ and design moment governed, the column shall be designed as beam and the above table is not applicable.
- The connection system between precast component and cast in-situ structure shall be referred to competent person.
- The design has been prepared in accordance with BS 8110 (1997).

PRECAST SQUARE COLUMN - DETAILS

Installation Stage Design

$H/2 + 105$
OR
 $B/2 + 105$

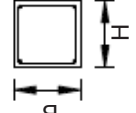
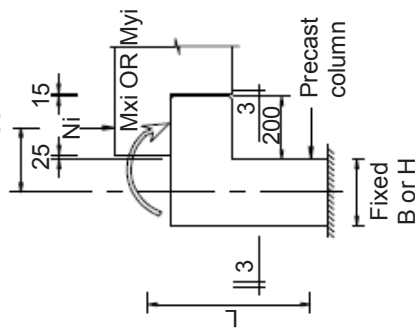

Section 3-3

Final Stage Design

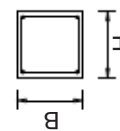
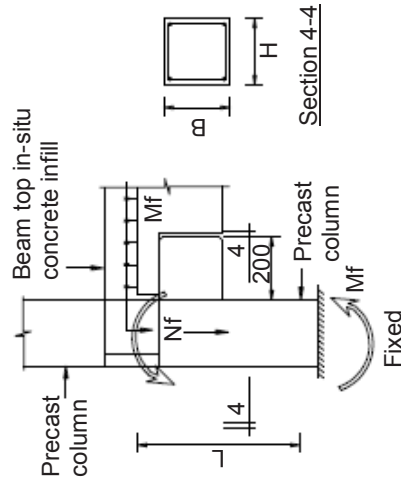

Section 4-4

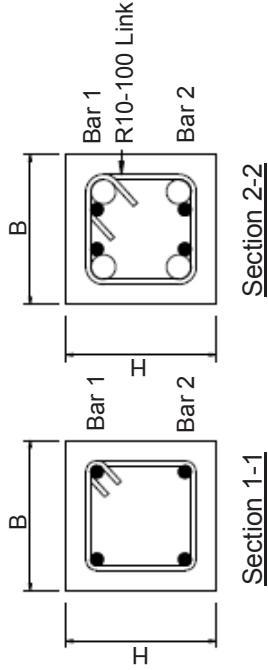

Type A (Main reinforcement = 4 nos)

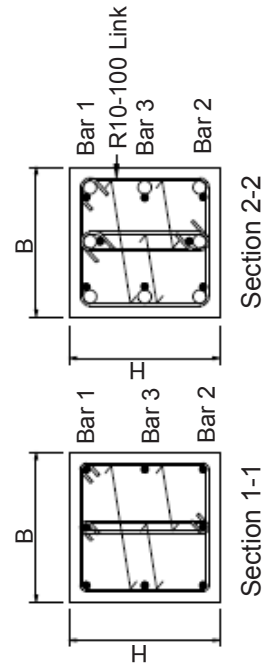

Type B (Main reinforcement = 8 nos)

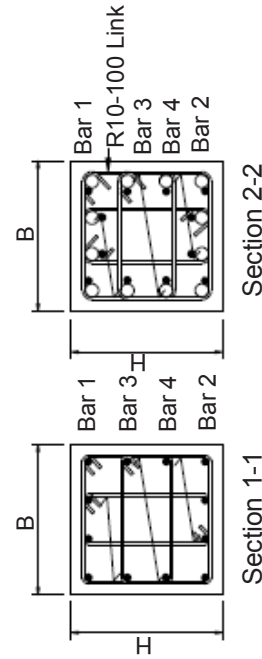

Type C (Main reinforcement = 12 nos)

Typical section of bars & links arrangement

Table 23

Square Column: i. For single-tier column, maximum length, L for the column shall be limited to 3m and 4m.
 ii. For double-tier column, maximum length, L for the column shall be limited to 6m, 7m and 8m.

Code of Component	Column Size B x H mm	Approx Selfweight (Precast) kN/m	Installation Stage Design		Final Stage Design		Reinforcement Detail					
			Maximum Axial Load N _i (kN)	Maximum Moment M _{xi} OR M _{yi} (kNm)	Maximum Axial Load N _f (kN)	Maximum Moment M _{xf} OR M _{yf} (kNm)	Bar 1	Bar 2	Bar 3	Bar 4	Links	
CS-3030-01	300 x 300	2.16	50	22	630	59	2T16	2T16	-	-	-	R10-175
			100	12	1000	55						
			150	2	1400	36						
CS-3030-02	300 x 300	2.16	50	31	630	62	2T20	2T20	-	-	-	R10-225
			100	21	1000	59						
			150	8	1500	41						
CS-3030-03	300 x 300	2.16	50	41	630	67	2T25	2T25	-	-	-	R10-300
			100	28	1000	65						
			150	15	1500	53						
CS-3535-01	350 x 350	2.94	200	2	1800	38	2T16	2T16	-	-	-	R10-175
			50	34	850	97						
			100	24	1000	97						
CS-3535-02	350 x 350	2.94	150	14	1500	83	2T20	2T20	-	-	-	R10-225
			200	3	1800	60						
			100	38	850	105						
CS-3535-03	350 x 350	2.94	150	27	1000	104	2T25	2T25	-	-	-	R10-300
			200	17	1500	93						
			250	6	1900	67						
CS-3535-03	350 x 350	2.94	150	47	850	117	2T25	2T25	-	-	-	R10-300
			200	36	1000	116						
			250	25	1500	106						
			300	12	2200	65						

Code of Component	Column Size B x H mm	Approx Selfweight (Precast) kN/m	Installation Stage Design		Final Stage Design		Reinforcement Detail				
			Maximum Axial Load N _i (kN)	Maximum Moment M _{xi} OR M _{yi} (kNm)	Maximum Axial Load N _f (kN)	Maximum Moment M _{xf} OR M _{yf} (kNm)	Bar 1	Bar 2	Bar 3	Bar 4	Links
CS-4040-01			50	45	1100	148	2T16	2T16	-	-	R10-175
			100	35	2000	116					
			150	25	2300	85					
CS-4040-02	400 x 400	3.84	150	44	1100	161	2T20	2T20	-	-	R10-225
			200	34	2000	133					
			250	23	2500	82					
CS-4040-03			300	39	1100	181	2T25	2T25	-	-	R10-300
			350	28	2000	156					
			400	16	2500	116					
CS-4545-01			100	71	1400	230	2T20	2T20	-	-	R10-225
			200	50	2000	217					
			300	29	3000	124					
CS-4545-02	450 x 450	4.86	300	65	1400	259	2T25	2T25	-	-	R10-300
			400	42	2000	244					
			500	19	3000	163					
CS-4545-03			500	79	1400	311	2T32	2T32	-	-	R10-300
			600	55	2000	292					
			750	17	3500	166					

For reinforcement arrangement refer to page 99 – page 101

Table 24

Square Column: i. For single-tier column, maximum length, L for the column shall be limited to 3m and 4m.
 ii. For double-tier column, maximum length, L for the column shall be limited to 6m, 7m and 8m.

Code of Component	Column Size B x H mm	Approx Selfweight (Precast) kN/m	Installation Stage Design		Final Stage Design		Reinforcement Detail				
			Maximum Axial Load N _i (kN)	Maximum Moment M _{xi} OR M _{yi} (kNm)	Maximum Axial Load N _f (kN)	Maximum Moment M _{xf} OR M _{yf} (kNm)	Bar 1	Bar 2	Bar 3	Bar 4	Links
CS-5050-01			200	67	1750	313	2T20	2T20	-	-	R10-225
			300	46	2000	309					
			400	25	3000	248					
CS-5050-02	500 x 500	6.00	200	111	1750	352	2T25	2T25	-	-	R10-300
			300	90	2000	346					
			400	68	3000	286					
			500	45	3500	229					
			600	96	1750	421					
CS-5050-03			700	71	2000	412	2T32	2T32	-	-	R10-300
			800	46	3000	351					
			900	20	4000	235					
			200	176	2100	500					
			300	154	3000	452					
CS-5555-01			500	110	4500	277	3T20	3T20	2T20	-	3R10-225
			600	185	2100	598					
			700	161	3000	540					
			800	136	4000	442					
			900	111	5000	295					
CS-5555-02	550 x 550	7.26	1200	206	2100	773	3T25	3T25	2T25	-	3R10-300
			1300	177	3000	704					
			1400	148	4000	600					
			1500	110	5000	473					
			1600	65	5500	395					
CS-5555-03			1600	65	5500	395	3T32	3T32	2T32	-	3R10-300
			1500	110	5000	473					
			1400	148	4000	600					

Code of Component	Column Size B x H mm	Approx Selfweight (Precast) kN/m	Installation Stage Design		Final Stage Design		Reinforcement Detail					
			Maximum Axial Load N _i (kN)	Maximum Moment M _{si} OR M _{yi} (kNm)	Maximum Axial Load N _f (kN)	Maximum Moment M _{xf} OR M _{yf} (kNm)	Bar 1	Bar 2	Bar 3	Bar 4	Links	
CS-6060-01			200	206	2500	628						
			300	185	3000	606						
			400	163	4000	526	3T20	3T20	2T20	-		3R10-225
			500	141	5000	390						
			600	118	5200	355						
			700	209	2500	745						
CS-6060-02	600 x 600	8.64	800	185	3000	715						
			900	160	4000	625	3T25	3T25	2T25	-		3R10-300
			1000	134	5000	498						
			1100	108	5500	415						
			1200	283	2500	954						
			1300	256	3000	912						
CS-6060-03			1400	228	4000	801	3T32	3T32	2T32	-		3R10-300
			1500	199	5000	683						
			1600	169	6000	527						
			200	237	3000	772						
			300	216	4000	713						
			400	194	5000	606	3T20	3T20	2T20	-		3R10-225
CS-6565-01			500	172	6000	438						
			600	280	3000	904						
			700	257	4000	824						
			800	233	5000	718						
			900	209	6000	563	3T25	3T25	2T25	-		3R10-300
			1000	183	6500	464						
CS-6565-02	650 x 650	10.14	1200	361	3000	1140						
			1400	306	4000	1041						
			1600	249	5000	920	3T32	3T32	2T32	-		3R10-300
			1800	188	6000	775						
			2000	121	7000	591						
			CS-6565-03									

For reinforcement arrangement refer to page 99 -- page 101

Table 25

Square Column: i. For single-tier column, maximum length, L for the column shall be limited to 3m and 4m.
 ii. For double-tier column, maximum length, L for the column shall be limited to 6m, 7m and 8m.

Code of Component	Column Size B x H mm	Approx Selfweight (Precast) kN/m	Installation Stage Design		Final Stage Design		Reinforcement Detail					
			Maximum Axial Load N _i (kN)	Maximum Moment M _x OR M _y (kNm)	Maximum Axial Load N _f (kN)	Maximum Moment M _x OR M _y (kNm)	Bar 1	Bar 2	Bar 3	Bar 4	Links	
CS-7070-01			300	378	3400	1061						
			500	334	4000	1037						
			700	288	5000	942	4T20	4T20	2T20	2T20		3R10-225
			900	241	6000	810						
			1100	191	7000	628						
			1300	356	3400	1284						
CS-7070-02	700 x 700	11.76	1500	301	5000	1135						
			1700	243	6000	1000	4T25	4T25	2T25	2T25		3R10-300
			1900	182	7000	831						
			2100	117	8000	617						
			2300	435	3400	1678						
			2500	353	6000	1345						
CS-7070-03			2700	244	7000	1182	4T32	4T32	2T32	2T32		3R10-300
			2900	122	8000	993						
			3000	61	9000	771						
			500	379	4000	1259						
			700	334	5000	1196						
			900	287	6000	1085						
CS-7575-01			1100	238	7000	932						
			1300	187	8000	728	4T20	4T20	2T20	2T20		3R10-225
			1100	478	4000	1505						
			1300	427	5000	1421						
			1900	258	8000	952	4T25	4T25	2T25	2T25		3R10-300
			2100	196	9000	716						
CS-7575-02	750 x 750	13.50	1900	689	4000	1940						
			2100	629	6000	1682						
			2300	563	7000	1521						
			2500	485	8000	1340	4T32	4T32	2T32	2T32		3R10-300
			2700	402	9000	1131						
			3000	268	10000	887						

Code of Component	Column Size B x H mm	Approx Selfweight (Precast) kN/m	Installation Stage Design		Final Stage Design		Reinforcement Detail				
			Maximum Axial Load N _i (kN)	Maximum Moment M _{xi} OR M _{yi} (kNm)	Maximum Axial Load N _f (kN)	Maximum Moment M _{xf} OR M _{yf} (kNm)	Bar 1	Bar 2	Bar 3	Bar 4	Links
CS-8080-01			500	424	4500	1474					
			700	379	6000	1376					
			900	333	7000	1248	4T20	4T20	2T20	2T20	3R10-225
			1100	285	8000	1077					
			1300	235	9000	854					
CS-8080-02	800 x 800	15.36	1100	548	4500	1743					
			1300	498	6000	1615					
			1500	445	7000	1476					
			1700	390	8000	1308	4T25	4T25	2T25	2T25	3R10-300
			1900	332	9000	1100					
			2100	272	10000	845					
			1900	803	4500	2219					
CS-8080-03			2100	745	7000	1894					
			2300	684	8000	1720					
			2500	613	9000	1523	4T32	4T32	2T32	2T32	3R10-300
			2700	535	10000	1296					
			3000	408	11000	1032					

For reinforcement arrangement refer to page 99 – page 101



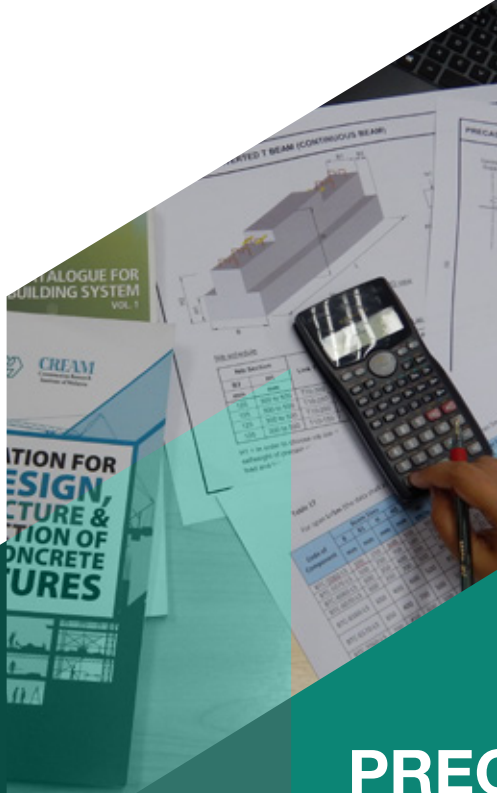

PRECAST COMPONENT

- A. PRECAST RECTANGULAR BEAM (SIMPLY SUPPORTED)
- B. PRECAST RECTANGULAR BEAM (CONTINUOUS BEAM)
- C. PRECAST INVERTED T BEAM (CONTINUOUS BEAM)
- D. PRECAST EDGE BEAM (CONTINUOUS BEAM)
- E. PRECAST SQUARE COLUMN
- F. PRECAST RECTANGULAR COLUMN**
- G. PRECAST HALF SLAB (CONTINUOUS SUPPORTED)
- H. PRECAST HOLLOWCORE SLAB
- I. PRECAST PRESTRESSED PLANK
- J. PRECAST WALL (LOAD BEARING)
- K. PRECAST WALL (NON-LOAD BEARING)
- L. PRECAST STAIRCASE
- M. PRECAST CORBEL CONNECTION
- N. PRECAST COLUMN NIB CONNECTION
- O. PRECAST HALF JOINT CONNECTION
- P. WET JOINT CONNECTION

NOTES

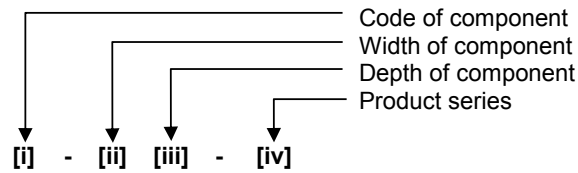

[i] Types of Component

Code	Component
CR	Precast rectangular column

[ii] Width of Component

Depends on component range

[iii] Depth of Component

Depends on component range

[iv] Product Series

Depends on maximum axial load of component

Notation

M_{xi} = Maximum moment capacity during installation stage design for stronger axis

M_{yi} = Maximum moment capacity during installation stage design for weaker axis

N_i = Maximum axial load during installation stage design

M_{xf} = Maximum moment capacity during final stage design for stronger axis

M_{yf} = Maximum moment capacity during final stage design for weaker axis

N_f = Maximum axial load during final stage design

For installation stage design, maximum moment shall be M_{xi} only.

For final stage design, maximum moment shall be M_{xf} only.

PRECAST RECTANGULAR COLUMN

CODE OF COMPONENTS

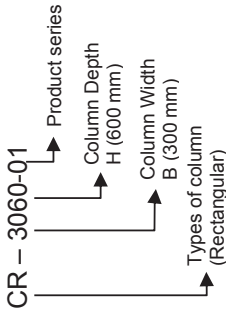

Specification

Installation Stage design

- Bottom end shall be design as condition 1 whereas top end shall be designed as condition 4 (i.e. free cantilever), as per BS 8110 Part 1 cl. 3.8.1.6.2.
- Minimum concrete grade C25.
- Madd = $(N_h/2000) \frac{L_s}{L} K$ in BS 8110 Part 1 cl. 3.8.3.1 shall be computed by user and Madd shall be smaller than Mint

Lap schedule

Reinforcement Bar Size (mm)	Lap Length (mm)
12	500
16	650
20	800
25	1000
32	1300

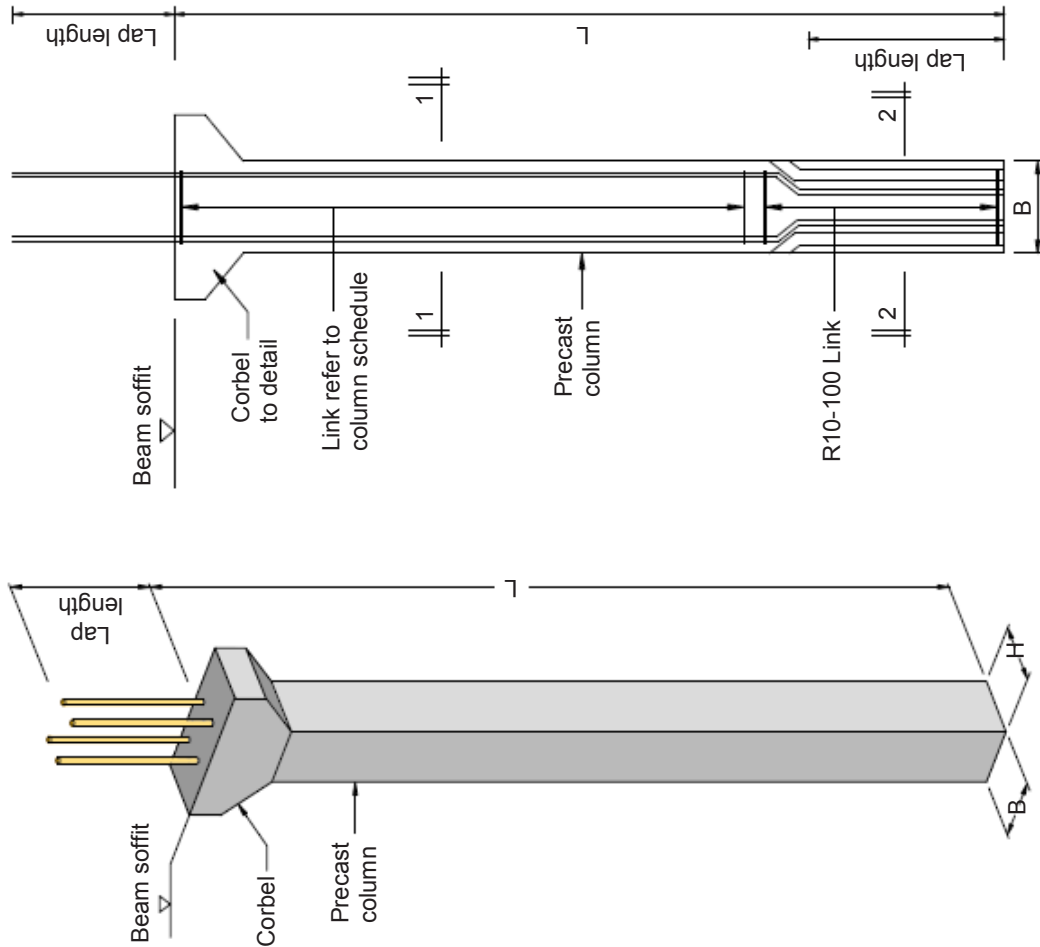

Typical column
Single Tier (3D view)

Typical column
(Elevation-Single Tier)

PRECAST RECTANGULAR COLUMN

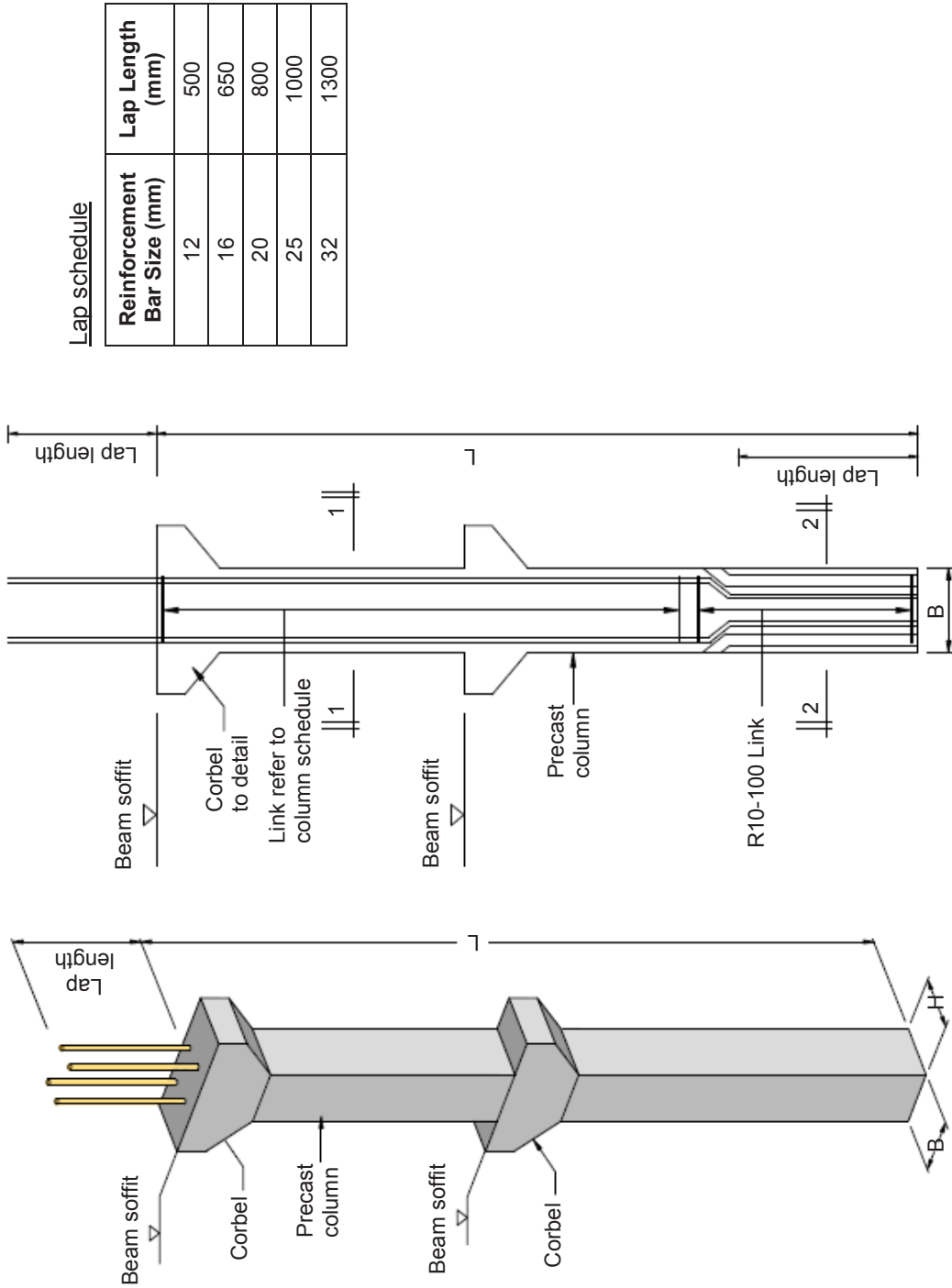

Typical column Double Tier (3D view)

Typical column (Elevation-Double Tier)

Specification

Final Stage Design

- a. Resultant of design moment (M) in consideration of M_x , M_y , M_i , M_{min} and M_{add} shall be computed by users.
- b. Ultimate force due to selfweight of precast beam, precast slab, beam top concrete infill, slab topping, superimposed dead load and live load shall be computed by user and total load shall be smaller than N_f .
- c. All end condition shall be designed as condition as per BS 8110 Part 1: 1997 cl. 3.8.1.6.2.
- d. Minimum concrete grade C35 (Precast and cast in-situ concrete).
- e. All design is compliance with BS 8110 Part 1:1997 and BS 8110 Part 3:1985
- f. For the design of ultimate moment capacity, main bar position is considered 110mm from column face to main bar centre.
- g. Minimum concrete grade C25 for initial stage design.
- h. Concrete cover to main reinforcement = 40mm.
- i. Fire resistance = 2 hours.
- j. Characteristic of steel reinforcement
High tensile (T) $f_y = 460 \text{ N/mm}^2$
Mild steel (R) $f_{yv} = 250 \text{ N/mm}^2$
- k. In order to control crack due to bending in column, ultimate axial load at final stage must be greater than $0.2f_{cu}Ac$
- l. If ultimate axial load is smaller than $0.2f_{cu}Ac$ and design moment governed, the column shall be designed as beam and the above table is not applicable.
- m. The connection system between precast component and cast in-situ structure shall be referred to competent person.
- n. The design has been prepared in accordance with BS 8110 (1997).

PRECAST RECTANGULAR COLUMN – DETAILS

Installation Stage Design

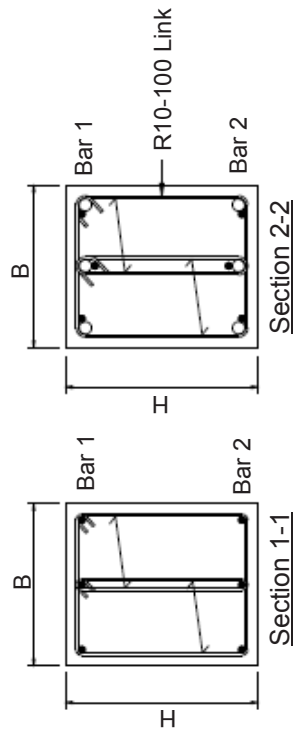
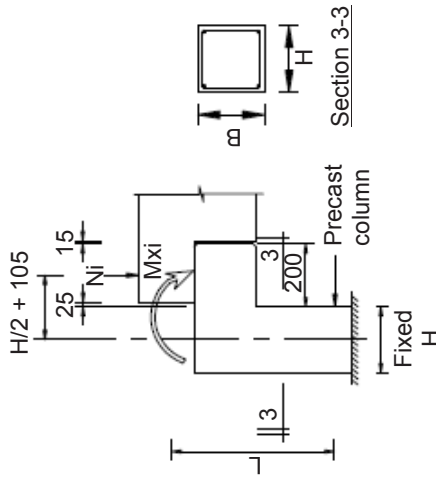

Type A (Main reinforcement = 6 nos)

Final Stage Design

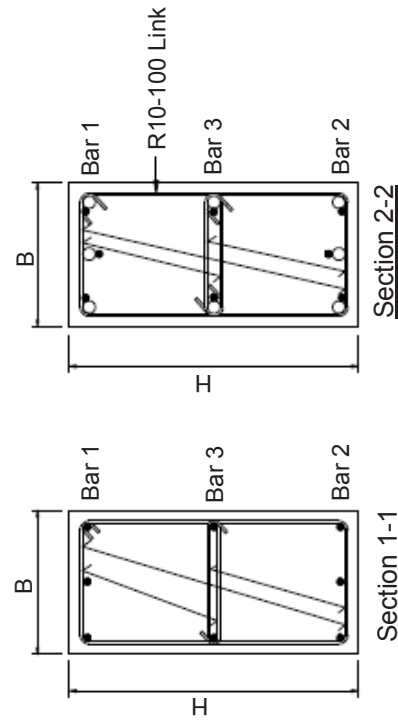
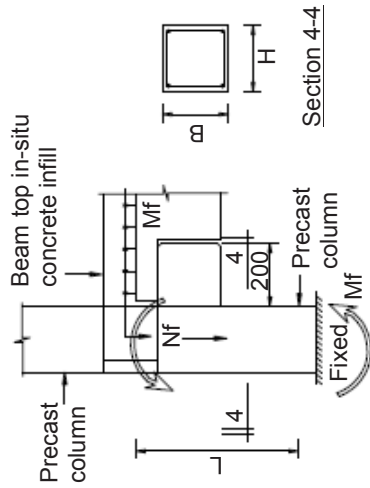

Type B (Main reinforcement = 8 nos)

Typical section of bars & links arrangement

Table 26

Rectangular Column: i. For single-tier column, maximum length, L for the column shall be limited to 3m and 4m.
 ii. For double-tier column, maximum length, L for the column shall be limited to 6m, 7m and 8m.

Code of Component	Column Size B x H mm	Approx Selfweight (Precast) kN/m	Installation Stage Design		Final Stage Design		Bar 1	Bar 2	Bar 3	Links
			Maximum Axial Load N _i (kN)	Maximum Moment M _{xi} OR M _{yi} (kNm)	Maximum Axial Load N _f (kN)	Maximum Moment M _{xf} OR M _{yf} (kNm)				
CR-3060-01			100	99	1300	310	3T16	3T16	-	2R10-175
			200	77	1500	299				
			300	55	2000	260				
			400	32	2500	191				
CR-3060-02	300 x 600	4.32	400	86	1300	366	3T20	3T20	-	2R10-225
			500	61	1500	351				
			600	34	2000	307				
			700	5	2800	192				
CR-3060-03			500	146	1300	454	3T25	3T25	-	2R10-300
			600	120	1500	434				
			700	92	2000	383				
			800	62	2500	322				
CR-4060-01			900	30	3000	242	3T20	3T20	-	2R10-225
			100	162	1700	437				
			200	141	2000	420				
			300	119	3000	326				
CR-4060-02	400 x 600	5.76	400	96	3500	248	3T25	3T25	-	2R10-300
			400	182	1700	525				
			600	133	2000	502				
			800	80	3000	402				
CR-4060-03			1000	23	3900	260	3T32	3T32	-	2R10-300
			600	285	1700	681				
			800	232	2000	651				
			1000	176	3000	538				
			1200	115	4000	394	3T32	3T32	-	2R10-300
			1400	12	4500	301				

Code of Component	Column Size B x H mm	Approx Selfweight (Precast) kN/m	Installation Stage Design		Final Stage Design		Bar 1	Bar 2	Bar 3	Links
			Maximum Axial Load N _i (kN)	Maximum Moment M _{x,i} OR M _{y,i} (kNm)	Maximum Axial Load N _r (kN)	Maximum Moment M _{x,r} OR M _{y,r} (kNm)				
CR-4080-01			500	233	2300	819	3T20	3T20	2T20	3R10-225
			700	182	3000	758				
			900	127	4000	607				
			1000	97	4700	451				
CR-4080-02	400 x 800	7.68	1000	274	2300	998	3T25	3T25	2T25	3R10-300
			1200	212	3000	921				
			1400	133	4000	761				
			1600	45	5200	488				
CR-4080-03			1200	529	2300	1316	3T32	3T32	2T32	3R10-300
			1400	451	3000	1219				
			1600	363	4000	1040				
			1800	250	5000	833				

For reinforcement arrangement refer to page 111 - page 113



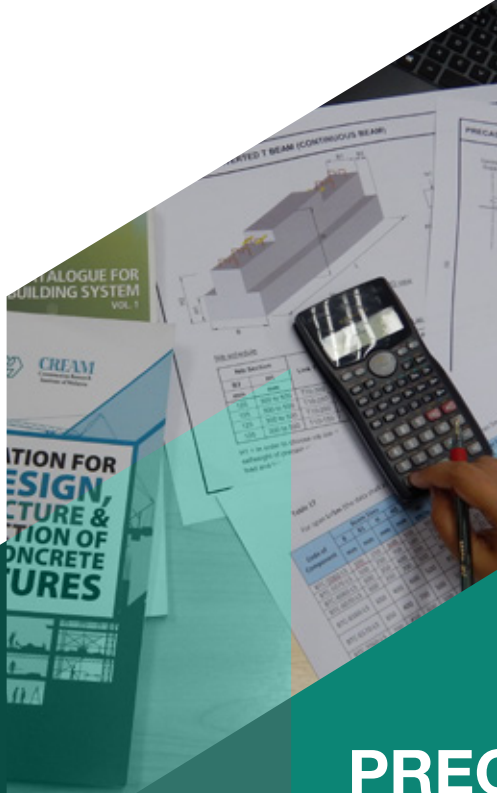

PRECAST COMPONENT

- A. PRECAST RECTANGULAR BEAM (SIMPLY SUPPORTED)
- B. PRECAST RECTANGULAR BEAM (CONTINUOUS BEAM)
- C. PRECAST INVERTED T BEAM (CONTINUOUS BEAM)
- D. PRECAST EDGE BEAM (CONTINUOUS BEAM)
- E. PRECAST SQUARE COLUMN
- F. PRECAST RECTANGULAR COLUMN
- G. PRECAST HALF SLAB (CONTINUOUS SUPPORTED)**
- H. PRECAST HOLLOWCORE SLAB
- I. PRECAST PRESTRESSED PLANK
- J. PRECAST WALL (LOAD BEARING)
- K. PRECAST WALL (NON-LOAD BEARING)
- L. PRECAST STAIRCASE
- M. PRECAST CORBEL CONNECTION
- N. PRECAST COLUMN NIB CONNECTION
- O. PRECAST HALF JOINT CONNECTION
- P. WET JOINT CONNECTION

NOTES

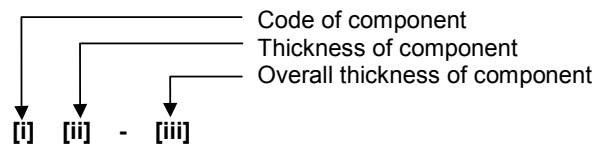

[i] Types of Component

Code	Component
HS	Precast half slab

[ii] Thickness of Component

Depends on component range

[iii] Overall Thickness of Component

Depends on component range

Notation

- M_u = Maximum moment capacity at mid span during final stage
 V = Maximum shear capacity at support during final stage
 w = Uniformly distributed ultimate load during final stage

PRECAST HALF SLAB - (CONTINUOUS SUPPORTED)

Precast half slab thickness, T = 65mm AND 75mm
 Width of panel, W = 600mm, 1200mm, AND 2400mm

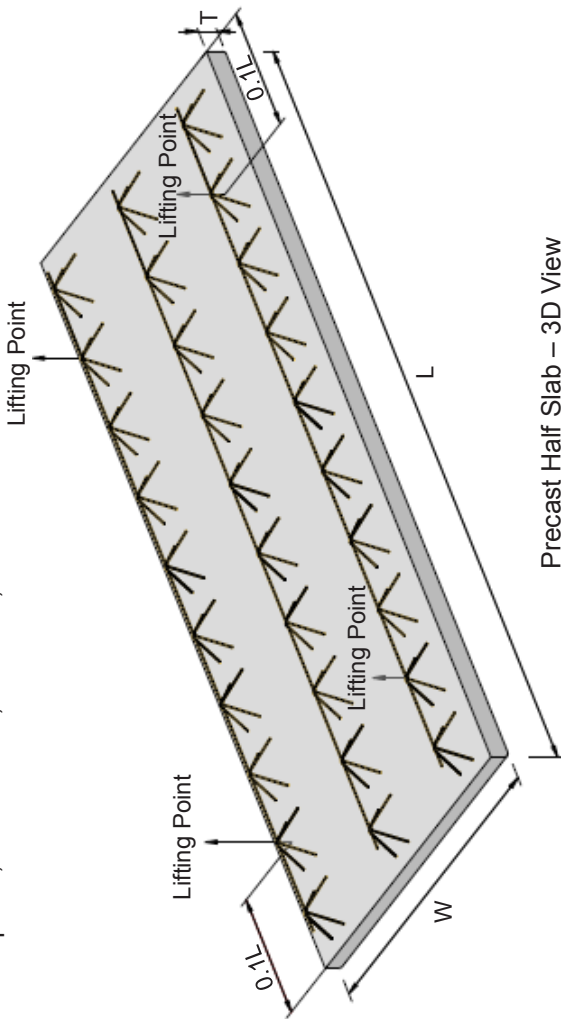

Precast Half Slab – 3D View

Lap Schedule

Reinforcement Bar D1	Length (mm)
10	400
12	500

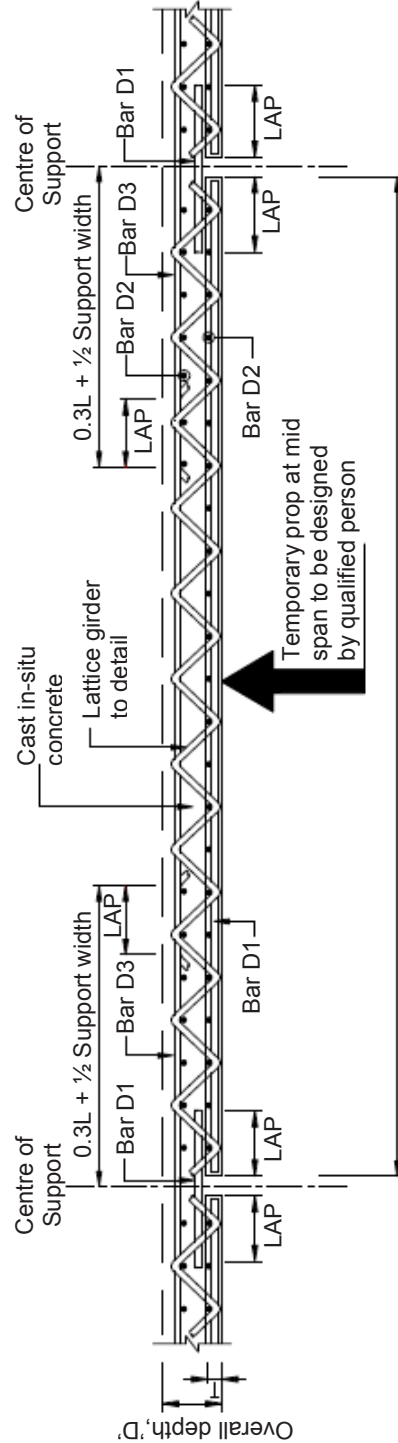

Slab Section Reinforcement Arrangement

CODE OF COMPONENTS

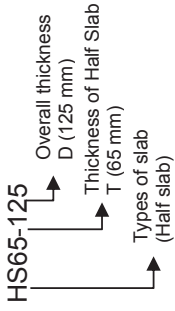

Specification

- Minimum concrete grade C35 (precast and cast in-situ concrete).
- Concrete cover = 25mm
- Fire resistance = 2 hours.
- Characteristic of steel reinforcement
 High tensile (T) fy = 460 N/mm²
 Mild steel (R) fy = 250 N/mm²
- Load should be uniformly distributed.
- The application of concentrated load area on precast element shall be referred to competent person.
- The above analysis is based on one way spanning slab, continuous and intermediate span design.
- The connection system between precast component and cast in-situ structure shall be referred to competent person.
- The design has been prepared in accordance with BS 8110 (1997).

PRECAST HALF SLAB - (CONTINUOUS SUPPORTED) DETAILS

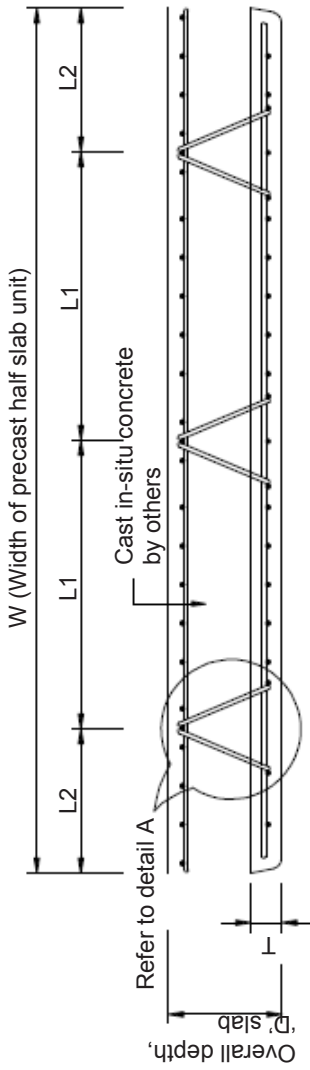

Section

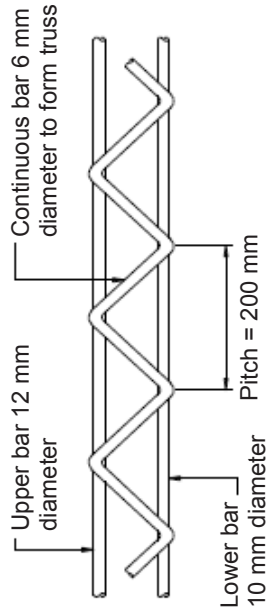
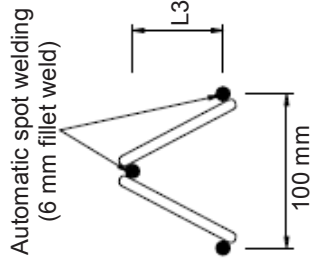

Typical lattice girder detail

Note:

- 1) The lattice girder and chamfer detail shall be fabricated to manufacturer's details.

Schedule 1: Lattice girder L1 and L2

W (mm)	L1 (mm)	L2 (mm)	Lattice Girder Provided
600	300	150	2
1200	450	150	3
2400	600	300	4

Schedule 2: Lattice Girder 3

Overall Depth 'D' (mm)	L3 (mm)
125	65
150	90
175	115
200	140

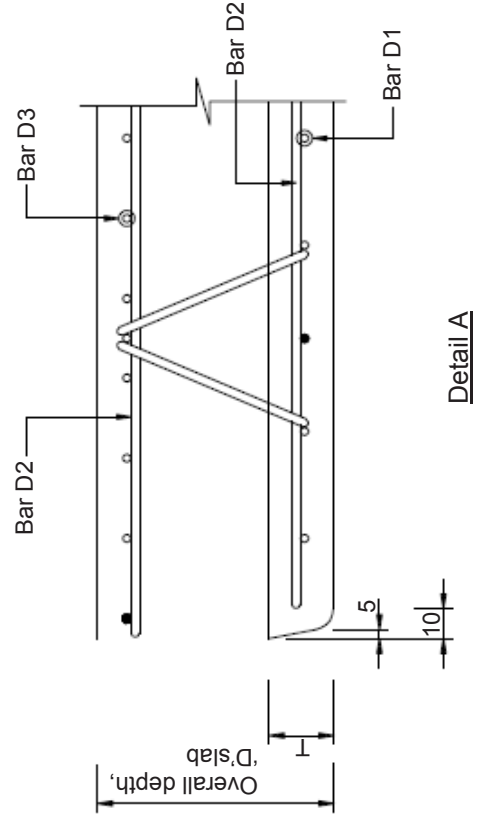

Table 27

For span **L=3m** (the data shall applies for span length, L equal or less than 3m subjected to moment and shear capacity required)

Code of Component	Dimension		Approx Selfweight (Precast) kN/m^2	Uniformly Distributed Load (w) kN/m	Max Moment M_u kN/m width		Max Shear V kN/m width	Reinforcement		
	Width W mm	Precast Half Slab Thickness T (mm)			Overall Depth D mm	Mid Span & Support		Bar D1	Bar D2	Bar D3
HS65-125	W	65	1.56	21.0	16	33	T10-150 c/c	T10-250 c/c	T10-150 c/c	

For reinforcement arrangement refer to page 119 – page 120

Table 28

For span **L=4m** (the data shall applies for span length, L equal or less than 4m subjected to moment and shear capacity required)

Code of Component	Dimension		Approx Selfweight (Precast) kN/m^2	Uniformly Distributed Load (w) kN/m	Max Moment M_u kN/m width		Max Shear V kN/m width	Reinforcement		
	Width W mm	Precast Half Slab Thickness T (mm)			Overall Depth D mm	Mid Span & Support		Bar D1	Bar D2	Bar D3
HS65-150	W	65	1.56	21.0	30	47	T10-100 c/c	T10-250 c/c	T10-100 c/c	
HS65-175	W	65	1.56	21.0	30	47	T10-150 c/c	T10-250 c/c	T10-150 c/c	

For reinforcement arrangement refer to page 119 – page 120

Table 29

For span **L=5m** (the data shall applies for span length, L equal or less than 5m subjected to moment and shear capacity required)

Code of Component	Dimension		Approx Selfweight (Precast) kN/m^2	Uniformly Distributed Load (w) kN/m	Max Moment M_u kN/m width		Max Shear V kN/m width	Reinforcement		
	Width W mm	Precast Half Slab Thickness T (mm)			Overall Depth D mm	Mid Span & Support		Bar D1	Bar D2	Bar D3
HS75-200	W	75	1.8	21.0	49	63	T10-100 c/c	T10-250 c/c	T10-100 c/c	

For reinforcement arrangement refer to page 119 – page 120



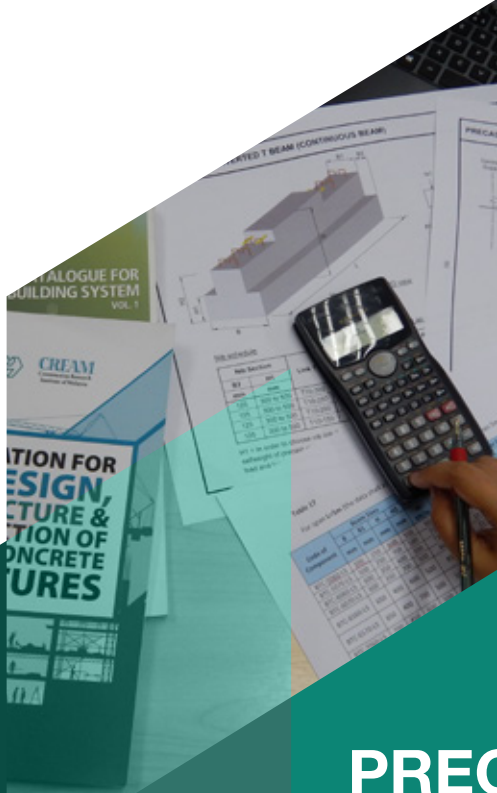

PRECAST COMPONENT

- A. PRECAST RECTANGULAR BEAM (SIMPLY SUPPORTED)
- B. PRECAST RECTANGULAR BEAM (CONTINUOUS BEAM)
- C. PRECAST INVERTED T BEAM (CONTINUOUS BEAM)
- D. PRECAST EDGE BEAM (CONTINUOUS BEAM)
- E. PRECAST SQUARE COLUMN
- F. PRECAST RECTANGULAR COLUMN
- G. PRECAST HALF SLAB (CONTINUOUS SUPPORTED)
- H. PRECAST HOLLOWCORE SLAB**
- I. PRECAST PRESTRESSED PLANK
- J. PRECAST WALL (LOAD BEARING)
- K. PRECAST WALL (NON-LOAD BEARING)
- L. PRECAST STAIRCASE
- M. PRECAST CORBEL CONNECTION
- N. PRECAST COLUMN NIB CONNECTION
- O. PRECAST HALF JOINT CONNECTION
- P. WET JOINT CONNECTION

NOTES

Code of Component

Code	Component
HCS	Precast hollowcore slab

PRECAST HOLLOW CORE SLAB

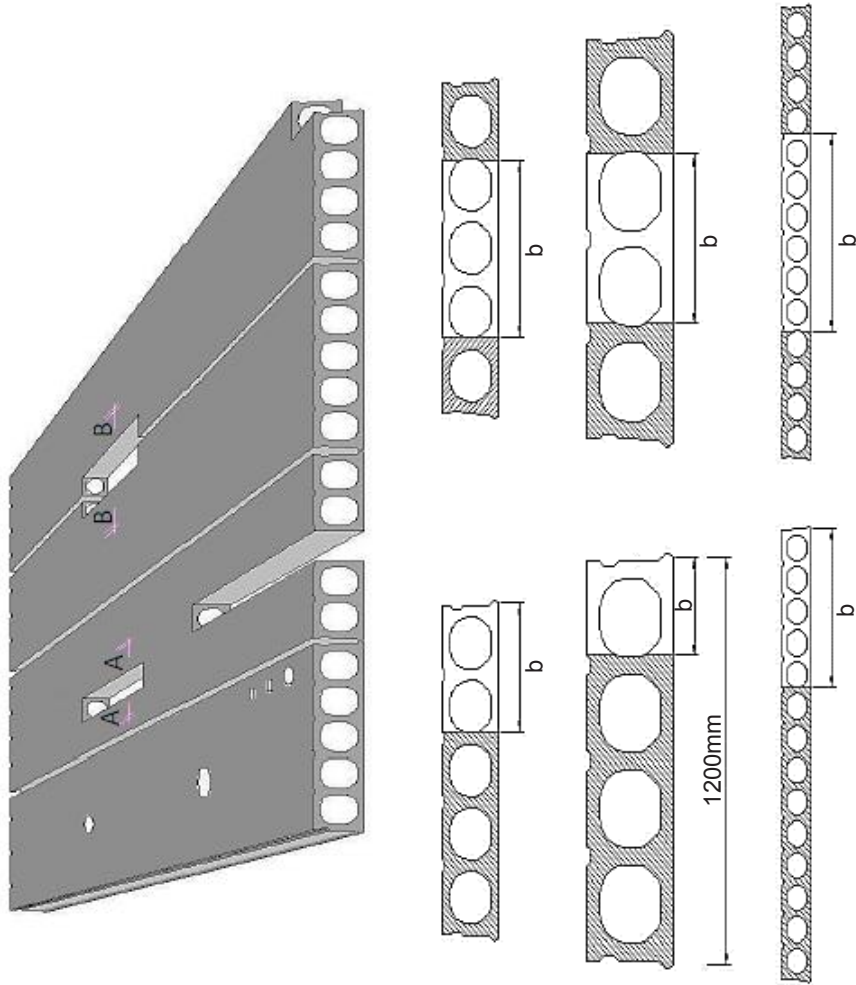

Section AA, $b \leq 430$ mm

Section BB, $b \leq 600$ mm

Figure 36. Examples of permitted sizes and locations of openings in precast hollow core slabs

CODE OF COMPONENTS

HCS

Note:

- a. Precast hollow core slab is also known as voided prestressed concrete slab. It is a one-way spanning prefabricated concrete slab, integrated with hollow cylinders, hence must be supported by fixed walls and/or beams. Since characteristics of slab is hollow, it reduces selfweight and also time of construction. Precast hollow core slab is popular in low-seismic prone zones.
- b. Process of manufacturing hollow core slab is done by extruding prestressed steel wire rope from a moving mould while concrete is still wet. Slab can be cut to required length and width by using circular diamond saw (refer Figure 36). Only permitted sizes and locations are allowed to make openings for any services with suitable fastenings, as shown in Figures 37a, 37b and 37c. Any random openings will affect the performance of hollow core slab. The thickness of web and flanged for the prestressed slab section varies between manufacturers.
- c. Both hollow core and massive slabs can be covered with soft floor covering to dampen sound of footsteps. Another option of soundproof is to apply a thin "floating" concrete on top of slab. Advantages of manufacturing hollow core slab are time saving and reduced training of manpower.
- d. Minimum concrete grade C50 for precast slab & grade C35 for cast in-situ toppings.
- e. Minimum concrete compressive strength of 25 N/mm² for first lifting.
- f. Minimum concrete compressive strength of 35 N/mm² for installation stage.

PRECAST HOLLOW CORE SLAB

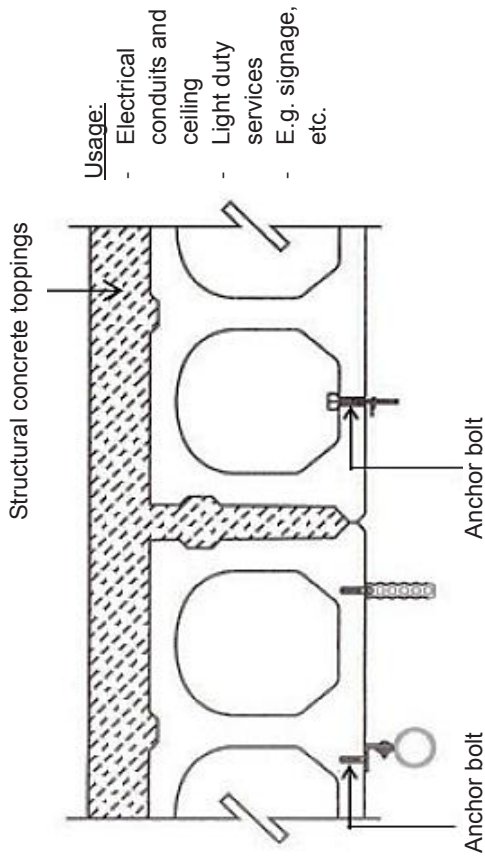

Figure 37 (a). Light duty fastening – light hangers using drill in anchor bolt.

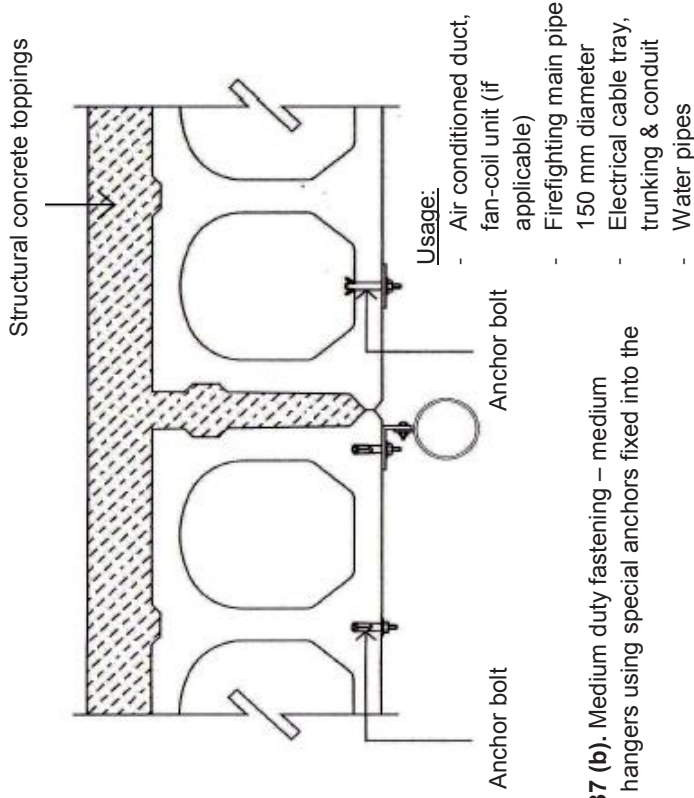

Figure 37 (b). Medium duty fastening – medium capacity hangers using special anchors fixed into the slab.

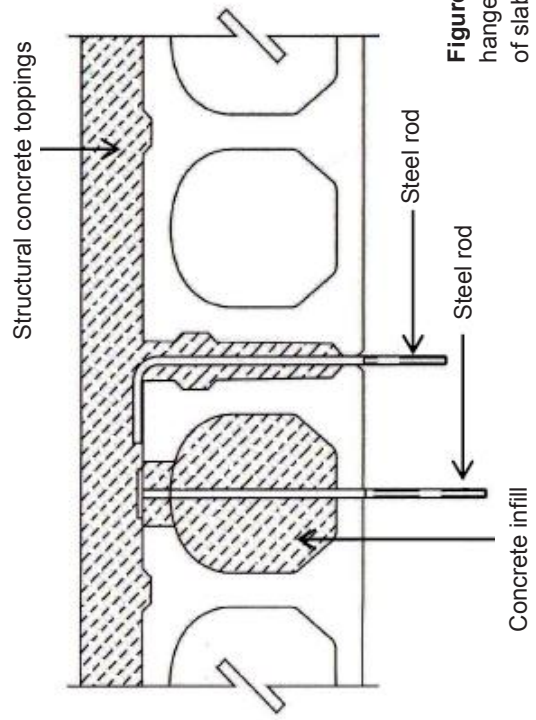

Figure 37 (c). Heavy duty fastening – heavy duty hangers are fixed through slab and supported from top of slab.



PRECAST COMPONENT

- A. PRECAST RECTANGULAR BEAM (SIMPLY SUPPORTED)
- B. PRECAST RECTANGULAR BEAM (CONTINUOUS BEAM)
- C. PRECAST INVERTED T BEAM (CONTINUOUS BEAM)
- D. PRECAST EDGE BEAM (CONTINUOUS BEAM)
- E. PRECAST SQUARE COLUMN
- F. PRECAST RECTANGULAR COLUMN
- G. PRECAST HALF SLAB (CONTINUOUS SUPPORTED)
- H. PRECAST HOLLOWCORE SLAB
- I. PRECAST PRESTRESSED PLANK**
- J. PRECAST WALL (LOAD BEARING)
- K. PRECAST WALL (NON-LOAD BEARING)
- L. PRECAST STAIRCASE
- M. PRECAST CORBEL CONNECTION
- N. PRECAST COLUMN NIB CONNECTION
- O. PRECAST HALF JOINT CONNECTION
- P. WET JOINT CONNECTION

NOTES

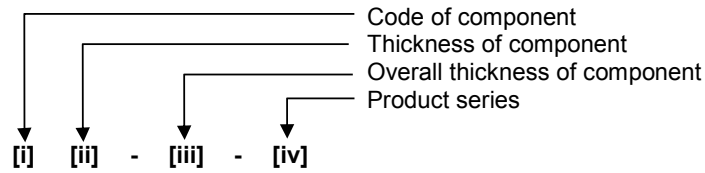

[i] Types of Component

Code	Component
PSP	Precast prestressed plank

[ii] Thickness of Component

Depends on component range

[iii] Overall Thickness of Component

Depends on component range

[iv] Product Series

Depends on the length of component

PRECAST PRESTRESSED PLANK

CODE OF COMPONENTS

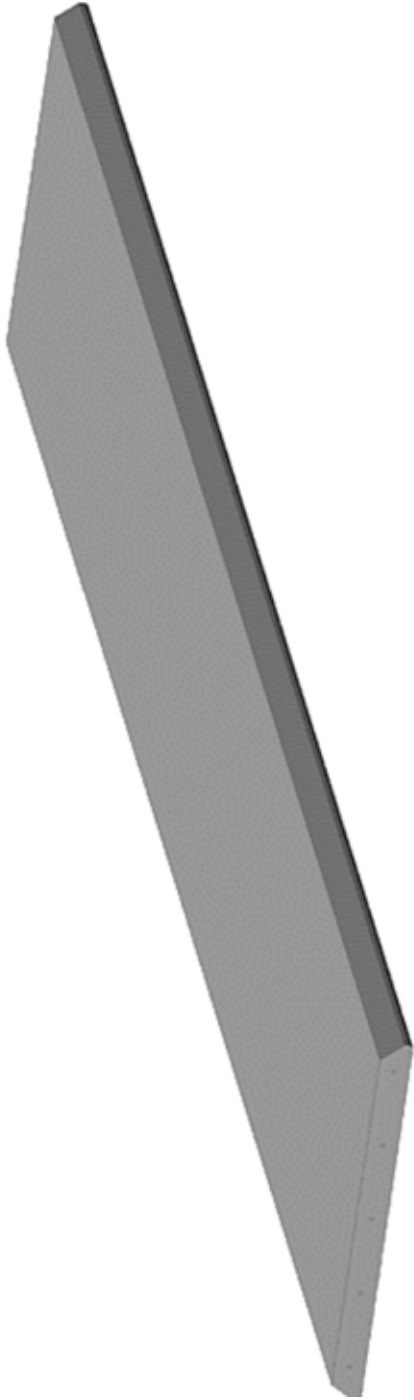

3D view



Front view

Precast Prestressed Plank

Specification

Final Stage Design

- a. Input value of Superimposed Dead Load (SDL) and Live Load (LL) shall be adopt by users.
- b. Selfweight of precast prestressed slab, are already compute in the provided table.
- c. Load should be uniformly distributed.
- d. The application of concentrated load area on precast element shall be referred to competent person.
- e. All end condition shall be designed as condition as per BS 8110.
- f. Minimum concrete grade C50 for precast slab & grade C35 for cast in-situ toppings.
- g. All design is compliance with BS 8110 Part 1:1997 and BS 8110 Part 3:1985
- h. For the design of ultimate moment capacity, the strand position is considered 40mm from the slab soffit
- i. Minimum concrete grade C35 for initial stage design.
- j. Minimum concrete compressive strength of 25 N/mm² for first lifting.
- k. Minimum concrete compressive strength of 35 N/mm² for installation stage.
- l. Concrete cover to main reinforcement = 40mm.
- m. Fire resistance = 2 hours.
- n. Characteristic of strand
- o. Tensile (T) fpu = 1860 Mpa
- p. The connection system between precast component and cast in-situ structure shall be referred to competent person.
- q. The design has been prepared in accordance with the BS 8110 (1997).

PRECAST PRESTRESSED PLANK – DETAILS

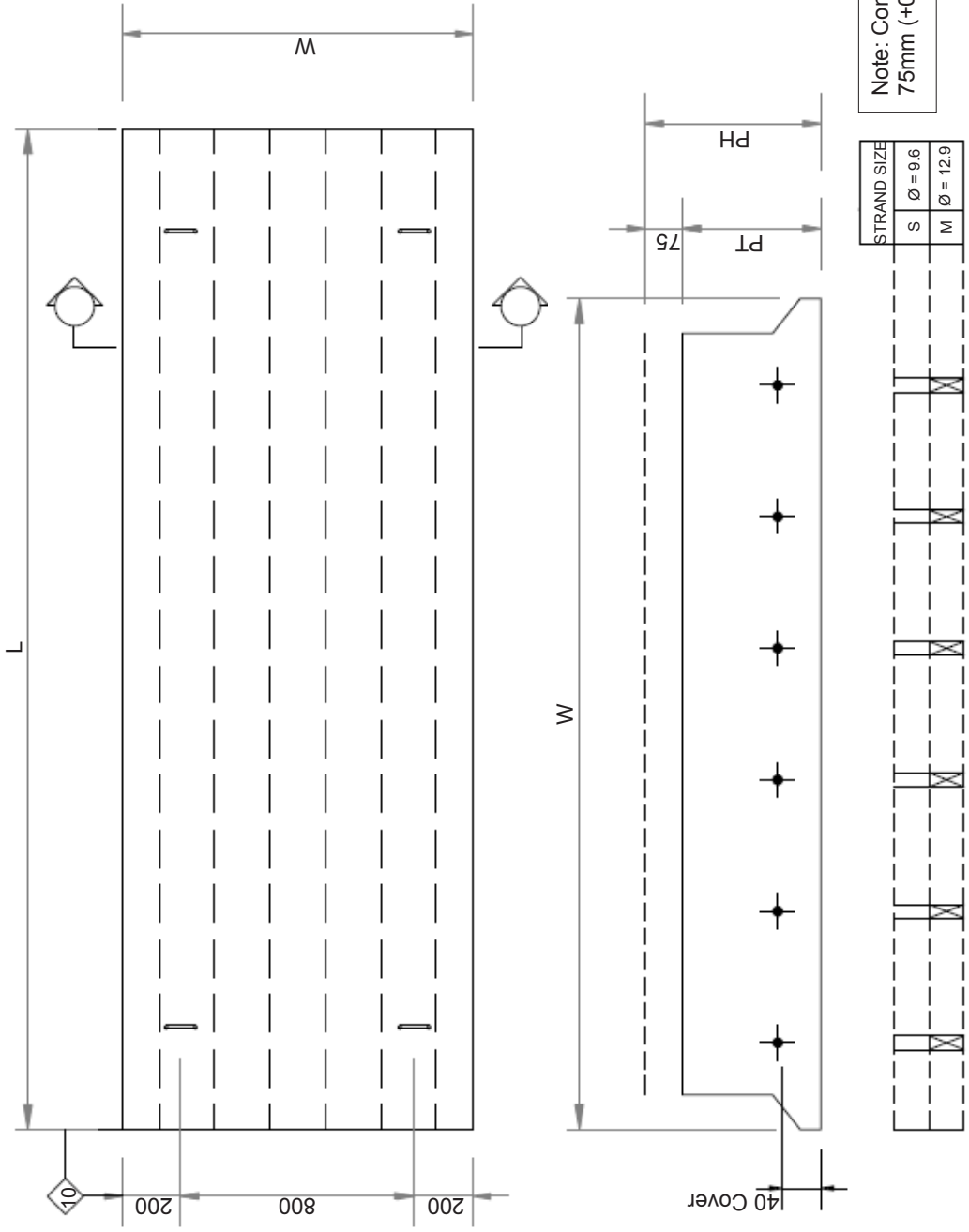

Typical section & reinforcement arrangement

Table 30

Code of Component	Dimension		Loading Data		(kN/m ²)		
	Plank Thickness PT (mm)	Plank Width W (mm)	Overall Thickness PH (mm)	Superimposed Dead Load SDL		1.7	
				Live Load LL		3.0	
PSP90-165-01	90	1200	165	3000		5S	5S
PSP90-165-02	90	1200	165	3500		5S	5M
PSP90-165-03	90	1200	165	4000		5M	5M
PSP90-165-04	90	1200	165	4500		6M	6M
				Length L (mm)		Strand (Nos)	

For reinforcement arrangement refer to page 129 – page 130

Table 31

Code of Component	Dimension		Loading Data		(kN/m ²)		
	Plank Thickness PT (mm)	Plank Width W (mm)	Overall Thickness PH (mm)	Superimposed Dead Load SDL		1.7	
				Live Load LL		3.0	
PSP100-175-01	100	1200	175	3000		5S	5S
PSP100-175-02	100	1200	175	3500		5S	5S
PSP100-175-03	100	1200	175	4000		5M	5M
PSP100-175-04	100	1200	175	4500		5M	5M
PSP100-175-05	100	1200	175	5000		5M	5M
PSP100-175-06	100	1200	175	5500		7M	7M
				Length L (mm)		Strand (Nos)	

For reinforcement arrangement refer to page 129 – page 130

Table 32

Code of Component	Dimension		Loading Data		(kN/m ²)			
	Plank Thickness PT (mm)	Plank Width W (mm)	Overall Thickness PH (mm)	Superimposed Dead Load SDL	1.7	1.7	1.7	1.7
					2.5	3.0	3.0	4.0
PSP125-200-01	125	1200	200		5S	5S	5S	5S
PSP125-200-02	125	1200	200		5S	5S	5S	5S
PSP125-200-03	125	1200	200		5S	5S	5S	5S
PSP125-200-04	125	1200	200		5S	5S	5S	6S
PSP125-200-05	125	1200	200		7S	7S	7S	5M
PSP125-200-06	125	1200	200		5M	5M	5M	5M
PSP125-200-07	125	1200	200		5M	5M	5M	6M
PSP125-200-08	125	1200	200		6M	7M	7M	7M

For reinforcement arrangement refer to page 129 – page 130

Table 33

Code of Component	Dimension		Loading Data		(kN/m ²)			
	Plank Thickness PT (mm)	Plank Width W (mm)	Overall Thickness PH (mm)	Superimposed Dead Load SDL	1.7	1.7	1.7	1.7
					2.5	3.0	3.0	4.0
PSP150-225-01	150	1200	225		5S	5S	5S	5S
PSP150-225-02	150	1200	225		5S	5S	5S	5S
PSP150-225-03	150	1200	225		5S	5S	5S	5S
PSP150-225-04	150	1200	225		5S	5S	5S	5S
PSP150-225-05	150	1200	225		5S	5S	5S	5S
PSP150-225-06	150	1200	225		5S	5S	5S	6S
PSP150-225-07	150	1200	225		7S	7S	7S	7S
PSP150-225-08	150	1200	225		5M	5M	5M	5M
PSP150-225-09	150	1200	225		5M	6M	6M	6M
PSP150-225-10	150	1200	225		6M	7M	7M	7M

For reinforcement arrangement refer to page 129 – page 130

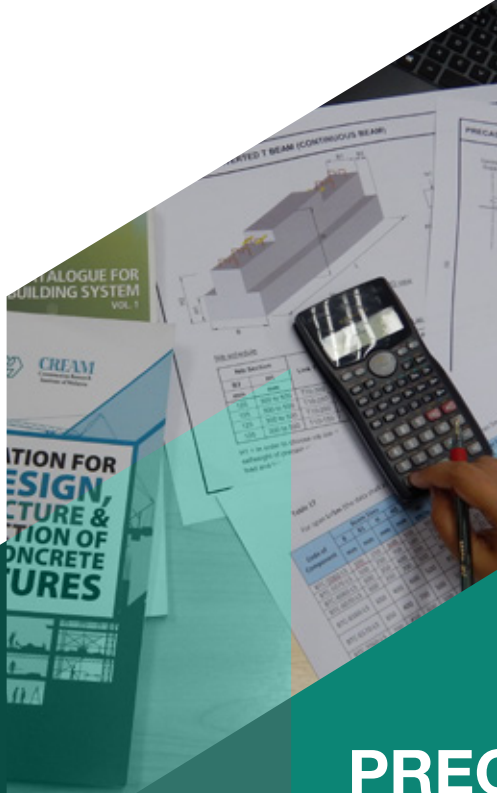

PRECAST COMPONENT

- A. PRECAST RECTANGULAR BEAM (SIMPLY SUPPORTED)
- B. PRECAST RECTANGULAR BEAM (CONTINUOUS BEAM)
- C. PRECAST INVERTED T BEAM (CONTINUOUS BEAM)
- D. PRECAST EDGE BEAM (CONTINUOUS BEAM)
- E. PRECAST SQUARE COLUMN
- F. PRECAST RECTANGULAR COLUMN
- G. PRECAST HALF SLAB (CONTINUOUS SUPPORTED)
- H. PRECAST HOLLOWCORE SLAB
- I. PRECAST PRESTRESSED PLANK
- J. PRECAST WALL (LOAD BEARING)**
- K. PRECAST WALL (NON-LOAD BEARING)
- L. PRECAST STAIRCASE
- M. PRECAST CORBEL CONNECTION
- N. PRECAST COLUMN NIB CONNECTION
- O. PRECAST HALF JOINT CONNECTION
- P. WET JOINT CONNECTION

NOTES

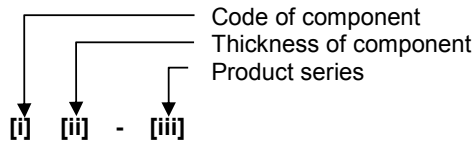

[i] Types of Component

Code	Component
WB	Precast load bearing wall

[ii] Thickness of Component

Depends on component range

[iii] Product Series

Depends on maximum moment of the component

Notation

M_w = Maximum moment

N_w = Ultimate axial load

PRECAST LOAD BEARING WALL

CODE OF COMPONENTS

WB150-01

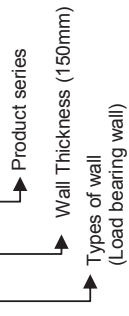

Specification

Final Stage Design

- a. Ultimate force due to selfweight of precast beam, precast slab, beam top concrete infill, slab topping, superimposed dead load and live load shall be computed by user and total load shall be smaller than Ultimate Axial Load, N_{uw} .
- b. Resultant of design moment (M_w) shall be computed by users.
- c. Confinement reinforcement to be adopt by user as per required.
- d. Minimum concrete grade C35 (Precast and Cast in-situ concrete).
- e. Concrete cover to main reinforcement = 25mm
- f. Fire resistance = 2 hours.
- g. Characteristic of steel reinforcement
High tensile (T) $f_y = 460 \text{ N/mm}^2$
Mild steel (R) $f_{yv} = 250 \text{ N/mm}^2$
- h. The connection detail may varies to the manufacturer's detail.

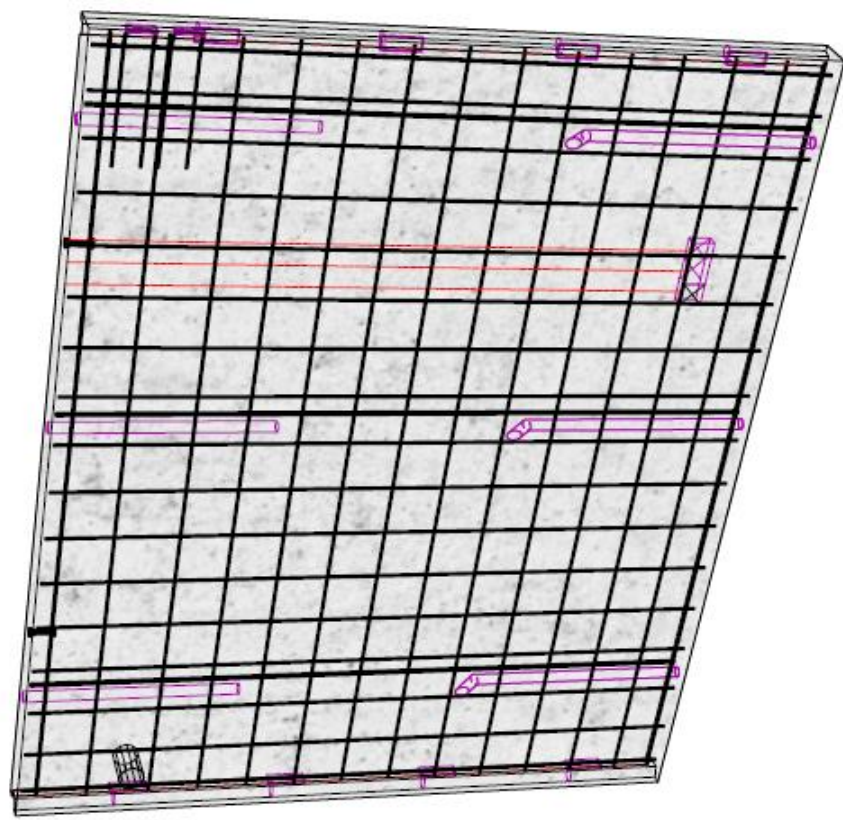

Precast Load Bearing Wall
3D View

PRECAST LOAD BEARING WALL – DETAILS

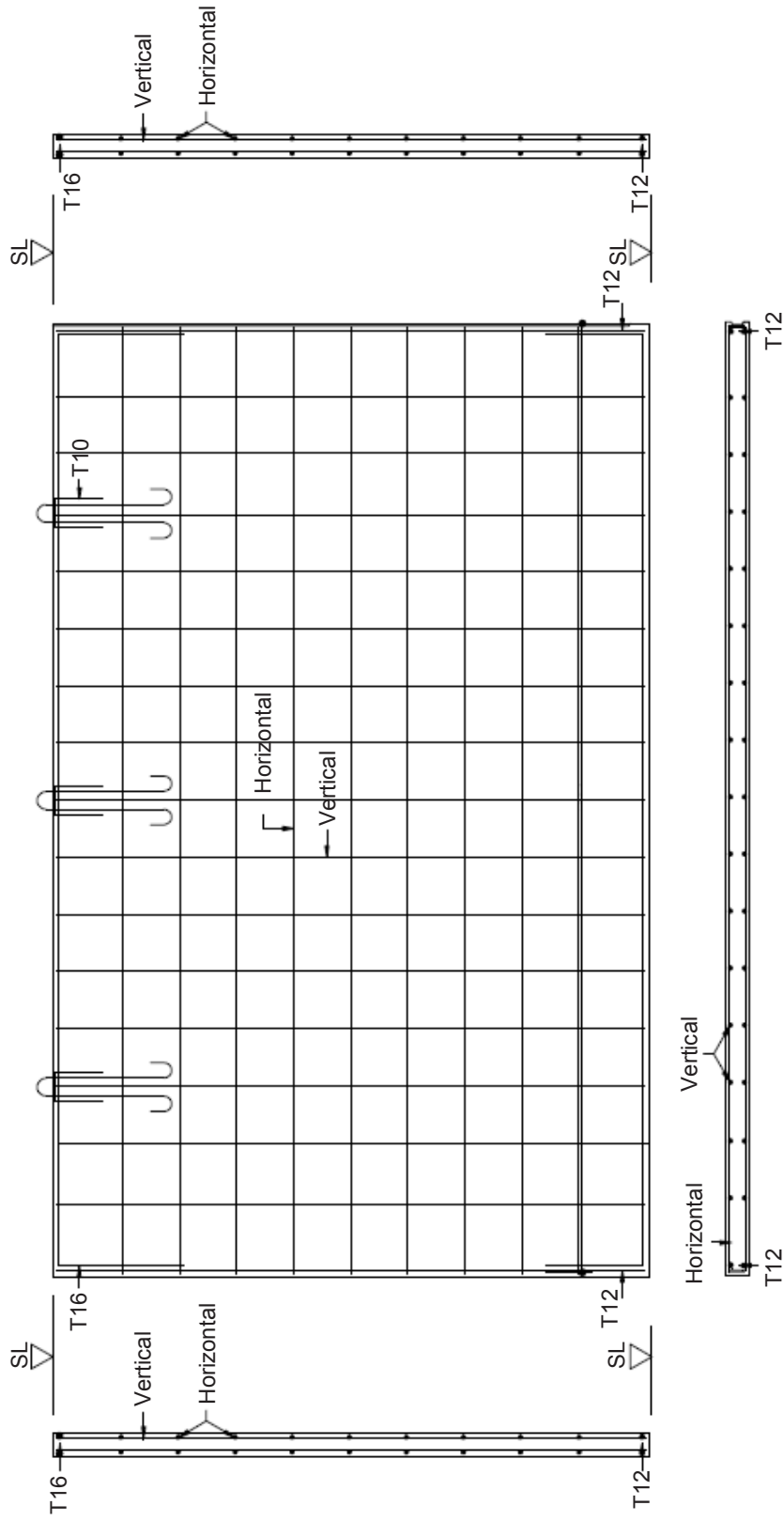

Reinforcement Arrangement for Precast Wall
(Load Bearing Wall)

Table 34

For floor height, H = 5.0 m

Code of Component	Wall Thickness (mm)	Ultimate Axial Load, N_w (kN/m)	Moment, M_w (kNm/m)	Rebar	
				Vertical	Horizontal
WB150-01	150	1500	50	T20-150	T10-250
WB150-02			40	T20-200	T10-250
WB150-03			30	T20-250	T10-250
WB150-04		1000	20	T20-300	T10-250
WB150-05			50	T16-200	T10-300
WB150-06			40	T16-250	T10-300
WB150-07			30	T16-275	T10-300
WB150-08	150	20	T16-300	T10-300	
WB150-09		50	T12-250	T10-300	
WB150-10		40	T12-250	T10-300	
WB150-11		30	T12-300	T10-300	
WB150-12		20	T10-150	T10-300	
WB150-13	250	50	T10-175	T10-300	
WB150-14		40	T10-200	T10-300	
WB150-15		30	T10-250	T10-300	
WB150-16		20	T10-250	T10-300	
WB200-01	200	2000	T20-100	T10-300	
WB200-02		1500	T20-125	T10-300	
WB200-03		1000	T16-125	T10-300	
WB200-04		500	T12-150	T10-300	
WB250-01	250	4000	T25-100	T10-250	
WB250-02		3500	T20-100	T10-250	
WB250-03		3000	T20-125	T10-250	
WB250-04		2500	T16-100	T10-250	
WB300-01	300	4500	T25-125	T10-200	
WB300-02		4000	T20-150	T10-200	
WB300-03		3500	T16-150	T10-200	
WB300-04		3000	T12-100	T10-200	

For reinforcement arrangement refer to page 135 – page 136

Table 35

For floor height, H = 4.5 m

Code of Component	Wall Thickness (mm)	Ultimate Axial Load, N_w (kN/m)	Moment, M_w (kNm/m)	Rebar	
				Vertical	Horizontal
WB150-01	150	1500	50	T20-150	T10-250
WB150-02			40	T20-200	T10-250
WB150-03			30	T20-275	T10-250
WB150-04		1000	20	T20-300	T10-250
WB150-05			50	T16-250	T10-300
WB150-06			40	T16-300	T10-300
WB150-07			30	T12-200	T10-300
WB150-08	500	20	T12-200	T10-300	
WB150-09		50	T12-225	T10-300	
WB150-10		40	T12-250	T10-300	
WB150-11		30	T12-300	T10-300	
WB150-12		20	T10-200	T10-300	
WB150-13	250	50	T10-175	T10-300	
WB150-14		40	T10-200	T10-300	
WB150-15		30	T10-250	T10-300	
WB150-16		20	T10-250	T10-300	
WB200-01	200	2000	T20-125	T10-300	
WB200-02		1500	T20-175	T10-300	
WB200-03		1000	T12-100	T10-300	
WB200-04		500	T10-125	T10-300	
WB250-01	250	4000	T20-100	T10-250	
WB250-02		3500	T20-125	T10-250	
WB250-03		3000	T20-150	T10-250	
WB250-04		2500	T16-125	T10-250	
WB300-01	300	4500	T25-125	T10-200	
WB300-02		4000	T20-150	T10-200	
WB300-03		3500	T16-150	T10-200	
WB300-04		3000	T12-100	T10-200	

For reinforcement arrangement refer to page 135 – page 136

Table 36

For floor height, H = 4.0 m

Code of Component	Wall Thickness (mm)	Ultimate Axial Load, N_w (kN/m)	Moment, M_w (kNm/m)	Rebar	
				Vertical	Horizontal
WB150-01	150	1500	50	T20-150	T10-250
WB150-02			40	T20-200	T10-250
WB150-03			30	T20-275	T10-250
WB150-04		1000	20	T20-300	T10-250
WB150-05			50	T16-250	T10-300
WB150-06			40	T16-300	T10-300
WB150-07			30	T12-200	T10-300
WB150-08	150	20	T12-200	T10-300	
WB150-09		50	T12-225	T10-300	
WB150-10		40	T12-250	T10-300	
WB150-11		30	T12-300	T10-300	
WB150-12		20	T10-200	T10-300	
WB150-13		50	T10-175	T10-300	
WB150-14		40	T10-200	T10-300	
WB150-15	250	30	T10-250	T10-300	
WB150-16		20	T10-250	T10-300	
WB200-01		90	T20-125	T10-300	
WB200-02		67	T20-200	T10-300	
WB200-03		45	T12-100	T10-300	
WB200-04		20	T10-150	T10-300	
WB250-01		250	180	T20-125	T10-250
WB250-02	150		T20-150	T10-250	
WB250-03	130		T16-100	T10-250	
WB250-04	110		T16-125	T10-250	
WB300-01	180		T25-150	T10-200	
WB300-02	160		T20-150	T10-200	
WB300-03	140		T16-150	T10-200	
WB300-04	120	T12-100	T10-200		

For reinforcement arrangement refer to page 135 – page 136

Table 37For floor height, **H = 3.5 m**

Code of Component	Wall Thickness (mm)	Ultimate Axial Load, N_w (kN/m)	Moment, M_w (kNm/m)	Rebar	
				Vertical	Horizontal
WB150-01	150	1500	75	T20-125	T10-300
WB150-02		1000	50	T16-150	T10-300
WB150-03		500	25	T10-200	T10-300
WB150-04		250	10	T10-200	T10-300
WB200-01	200	2000	75	T20-200	T10-300
WB200-02		1500	57	T16-150	T10-300
WB200-03		1000	35	T12-125	T10-300
WB200-04		500	20	T10-175	T10-300
WB250-01	250	4000	150	T20-150	T10-250
WB250-02		3500	130	T20-175	T10-250
WB250-03		3000	115	T16-125	T10-250
WB250-04		2500	95	T16-150	T10-250
WB300-01	300	4500	160	T20-100	T10-200
WB300-02		4000	140	T16-100	T10-200
WB300-03		3500	120	T16-150	T10-200
WB300-04		3000	110	T12-100	T10-200

For reinforcement arrangement refer to page 135 – page 136

Table 38For floor height, **H = 3.0 m**

Code of Component	Wall Thickness (mm)	Ultimate Axial Load, N_w (kN/m)	Moment, M_w (kNm/m)	Rebar	
				Vertical	Horizontal
WB150-01	150	1500	60	T16-125	T10-300
WB150-02		1000	40	T16-200	T10-300
WB150-03		500	20	T10-200	T10-300
WB150-04		250	10	T10-200	T10-300
WB200-01	200	2000	80	T20-200	T10-300
WB200-02		1500	50	T16-175	T10-300
WB200-03		1000	33	T12-150	T10-300
WB200-04		500	15	T10-200	T10-300
WB250-01	250	4000	130	T20-175	T10-250
WB250-02		3500	115	T16-125	T10-250
WB250-03		3000	95	T16-150	T10-250
WB250-04		2500	80	T12-100	T10-250
WB300-01	300	4500	140	T20-150	T10-200
WB300-02		4000	120	T16-100	T10-200
WB300-03		3500	110	T16-150	T10-200
WB300-04		3000	93	T12-100	T10-200

For reinforcement arrangement refer to page 135 – page 136





PRECAST COMPONENT

- A. PRECAST RECTANGULAR BEAM (SIMPLY SUPPORTED)
- B. PRECAST RECTANGULAR BEAM (CONTINUOUS BEAM)
- C. PRECAST INVERTED T BEAM (CONTINUOUS BEAM)
- D. PRECAST EDGE BEAM (CONTINUOUS BEAM)
- E. PRECAST SQUARE COLUMN
- F. PRECAST RECTANGULAR COLUMN
- G. PRECAST HALF SLAB (CONTINUOUS SUPPORTED)
- H. PRECAST HOLLOWCORE SLAB
- I. PRECAST PRESTRESSED PLANK
- J. PRECAST WALL (LOAD BEARING)
- K. PRECAST WALL (NON-LOAD BEARING)**
- L. PRECAST STAIRCASE
- M. PRECAST CORBEL CONNECTION
- N. PRECAST COLUMN NIB CONNECTION
- O. PRECAST HALF JOINT CONNECTION
- P. WET JOINT CONNECTION

NOTES

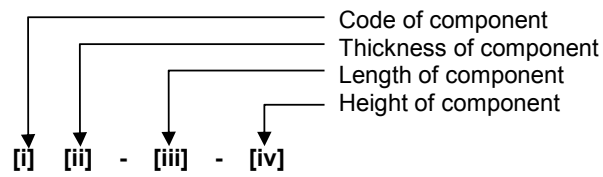

[i] Types of Component

Code	Component
NB	Precast non-load bearing wall

[ii] Thickness of Component

Depends on component range

[iii] Length of Component

Depends on component range

[iv] Height of Component

Depends on component range

PRECAST NON-LOAD BEARING WALL

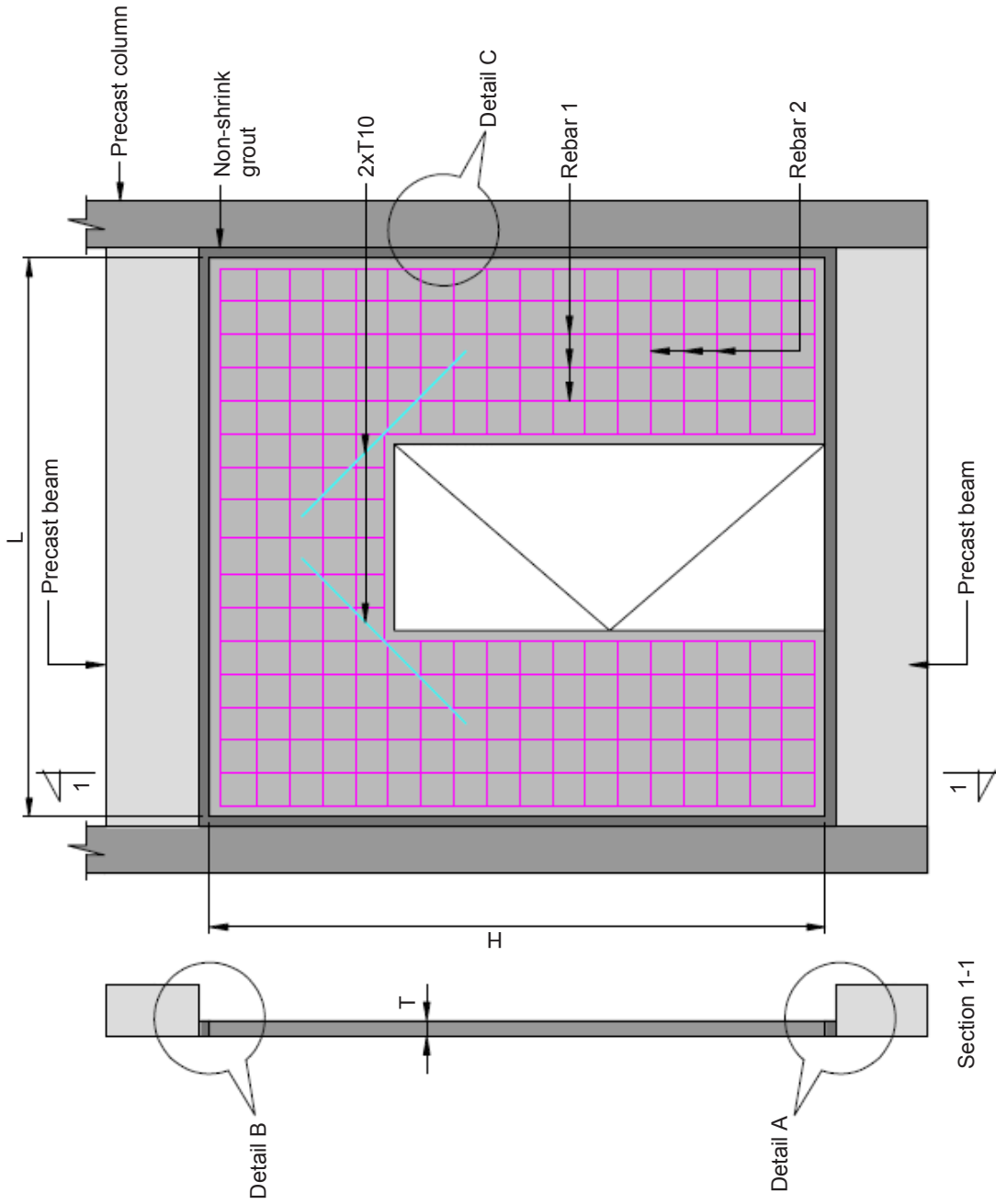

Reinforcement Arrangement for Precast Wall (Non-Load Bearing Wall)

CODE OF COMPONENTS

NB75 - 1500-2900

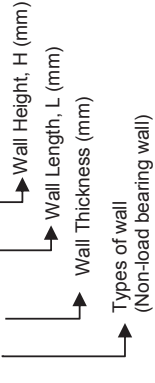

Specification

- a. Minimum concrete grade C35 (precast and cast in-situ concrete).
- b. Concrete cover to main reinforcement = 25mm
- c. Fire resistance = 2 hours.
- d. Characteristic of steel reinforcement
High tensile (T) $f_y = 460 \text{ N/mm}^2$
Mild steel (R) $f_{yv} = 250 \text{ N/mm}^2$
- e. The connection detail may vary to the manufacturer's detail.

PRECAST NON-LOAD BEARING WALL

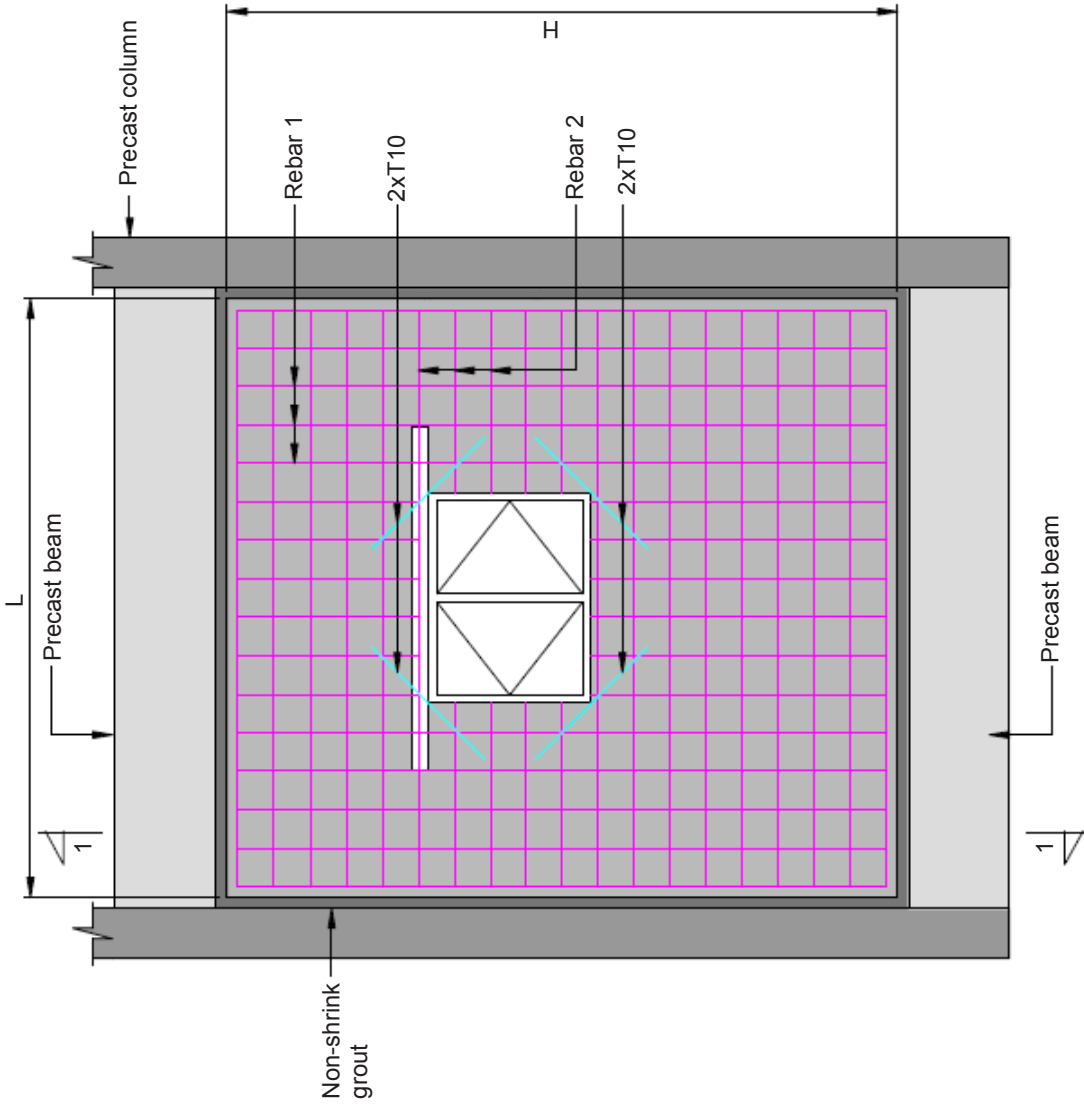

**Reinforcement Arrangement for Precast Wall
(Non-Load Bearing Wall)**

PRECAST NON-LOAD BEARING WALL - DETAILS

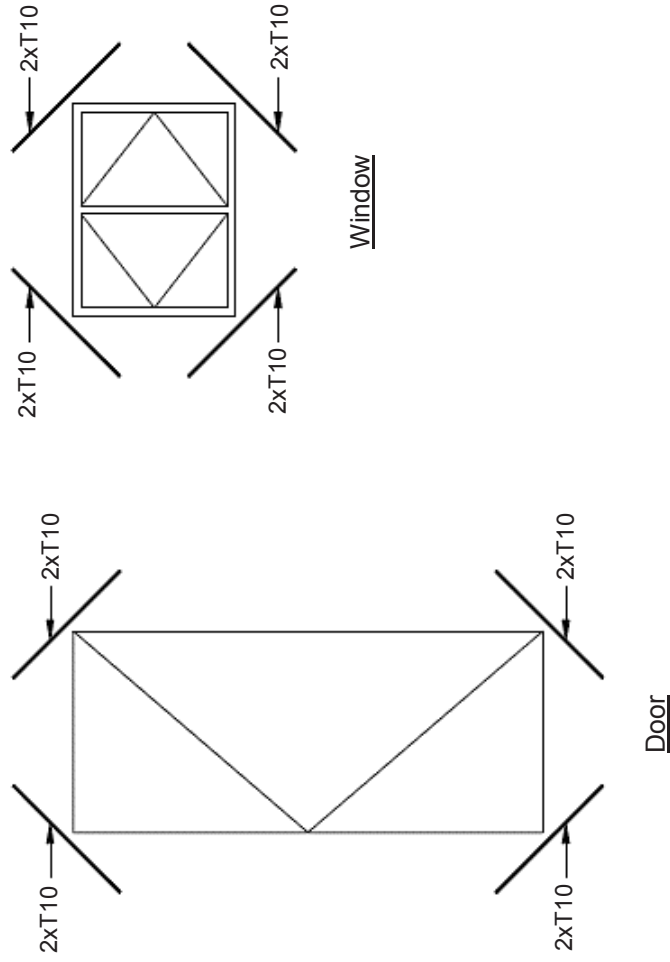

Typical Cracking Reinforcement at Wall Opening (Door & Window)



PRECAST NON-LOAD BEARING WALL - DETAILS

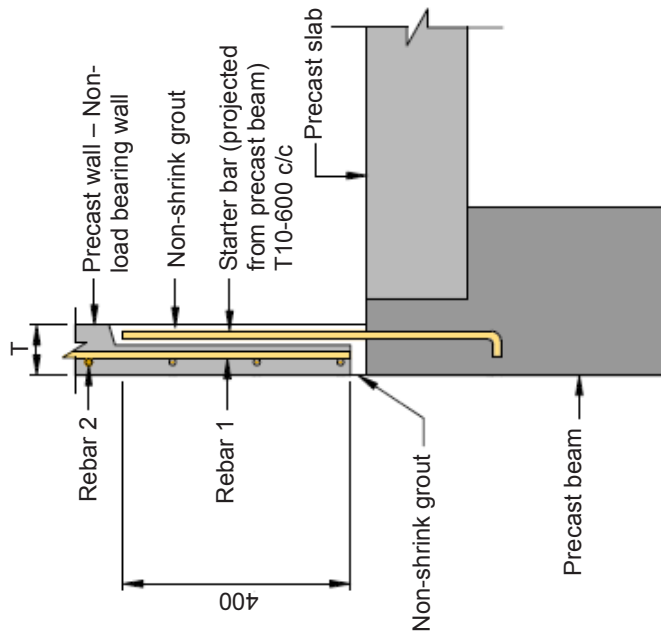

Detail A

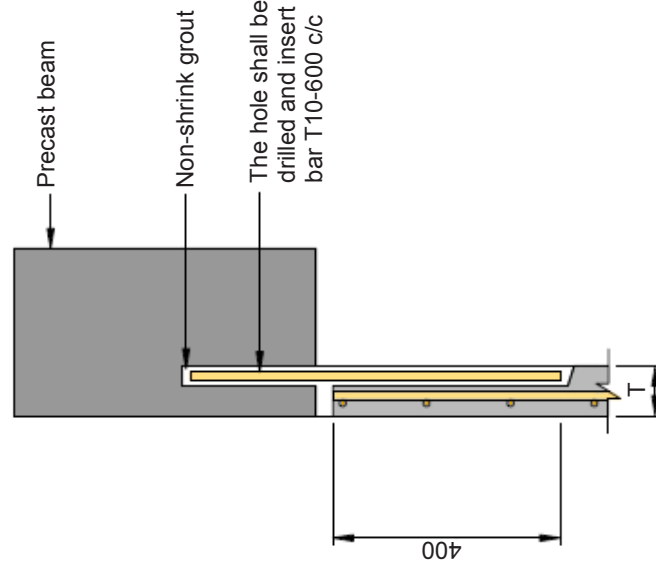

Detail B

PRECAST NON-LOAD BEARING WALL - DETAILS

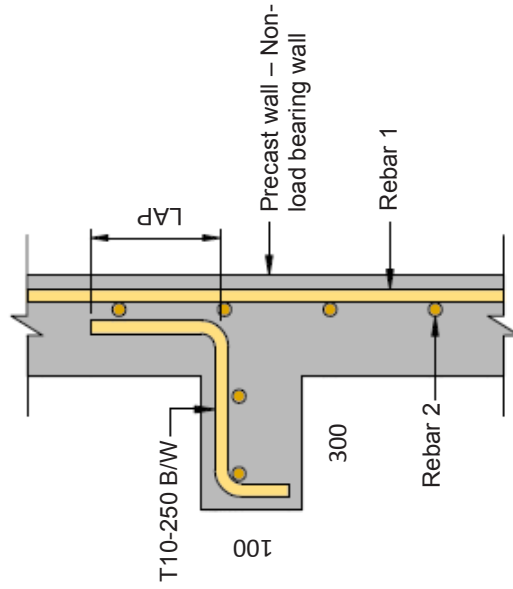

Typical RC hood

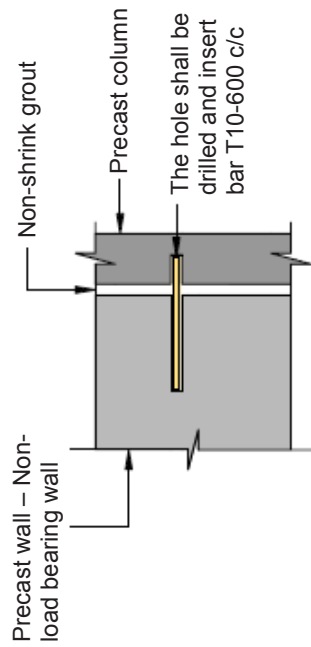

Detail C

Table 39

Codes of Components	Wall Thickness, T (mm)	Max Length, L (mm)	Max Height, H (mm)	Rebar 1	Rebar 2
NB75-3000-3000	75	*3000	*3000	T10-200	T10-200
NB100-3000-3000	100	*3000	*3000	T10-200	T10-200

*Size are adjustable to suit with requirement

For reinforcement arrangement refer to page 145 – page 149



PRECAST COMPONENT

- A. PRECAST RECTANGULAR BEAM (SIMPLY SUPPORTED)
- B. PRECAST RECTANGULAR BEAM (CONTINUOUS BEAM)
- C. PRECAST INVERTED T BEAM (CONTINUOUS BEAM)
- D. PRECAST EDGE BEAM (CONTINUOUS BEAM)
- E. PRECAST SQUARE COLUMN
- F. PRECAST RECTANGULAR COLUMN
- G. PRECAST HALF SLAB (CONTINUOUS SUPPORTED)
- H. PRECAST HOLLOWCORE SLAB
- I. PRECAST PRESTRESSED PLANK
- J. PRECAST WALL (LOAD BEARING)
- K. PRECAST WALL (NON-LOAD BEARING)
- L. PRECAST STAIRCASE**
- M. PRECAST CORBEL CONNECTION
- N. PRECAST COLUMN NIB CONNECTION
- O. PRECAST HALF JOINT CONNECTION
- P. WET JOINT CONNECTION

NOTES

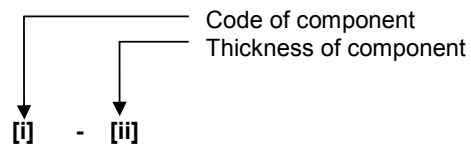

[i] Types of Component

Code	Component
SC	Precast staircase

[ii] Thickness of Component

Depends on component range

PRECAST STAIRCASE

CODE OF COMPONENTS

SC - 150

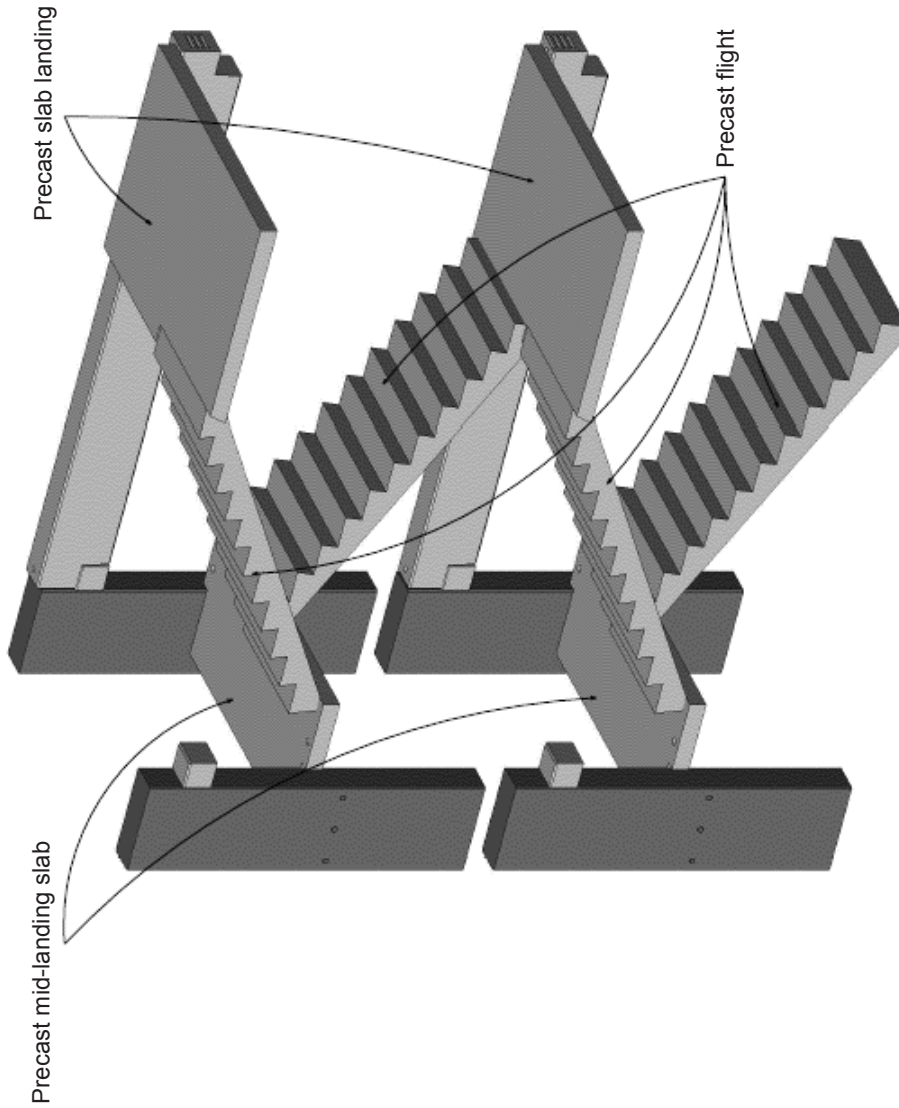

Precast Staircase
3D View

Specification

Final Stage Design

- a. Length / span of staircase to be adopted by user.
- b. Confinement reinforcement to be adopted by user as per required.
- c. Live Load (LL) = 4kN/m² adopted for design
- d. Minimum concrete grade C35 (precast and cast in-situ concrete).
- e. Concrete cover to main reinforcement = 25mm
- f. Fire resistance = 2 hours.
- g. Characteristic of steel reinforcement
High tensile (T) fy = 460 N/mm²
Mild steel (R) fyv = 250 N/mm²
- h. The connection detail may varies to the manufacturer's detail.

PRECAST STAIRCASE

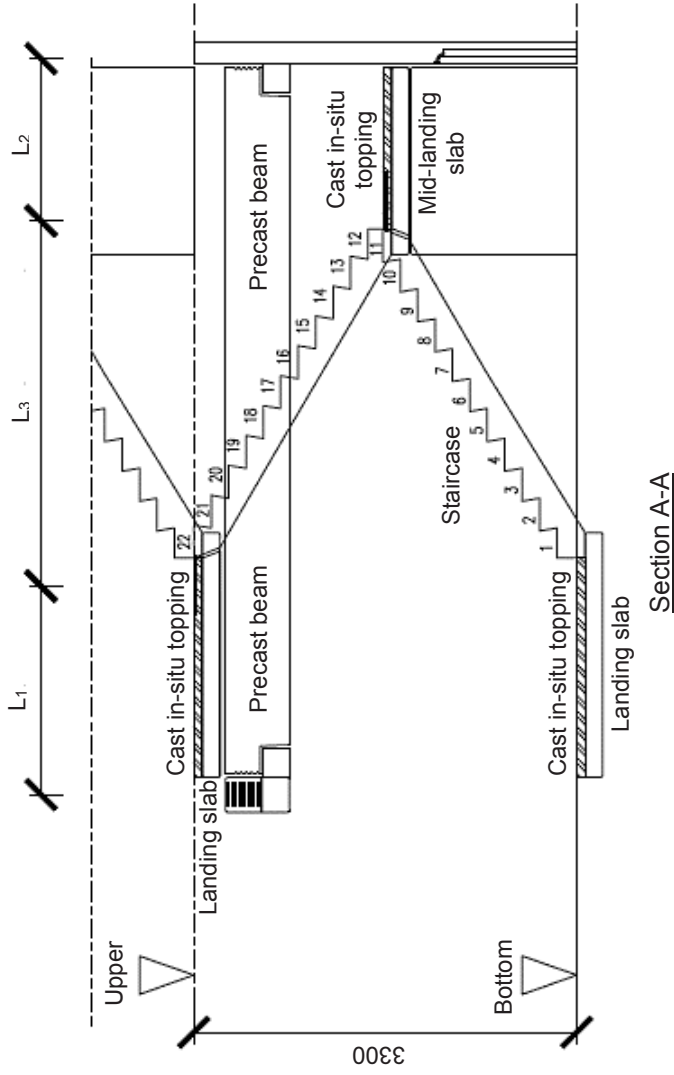
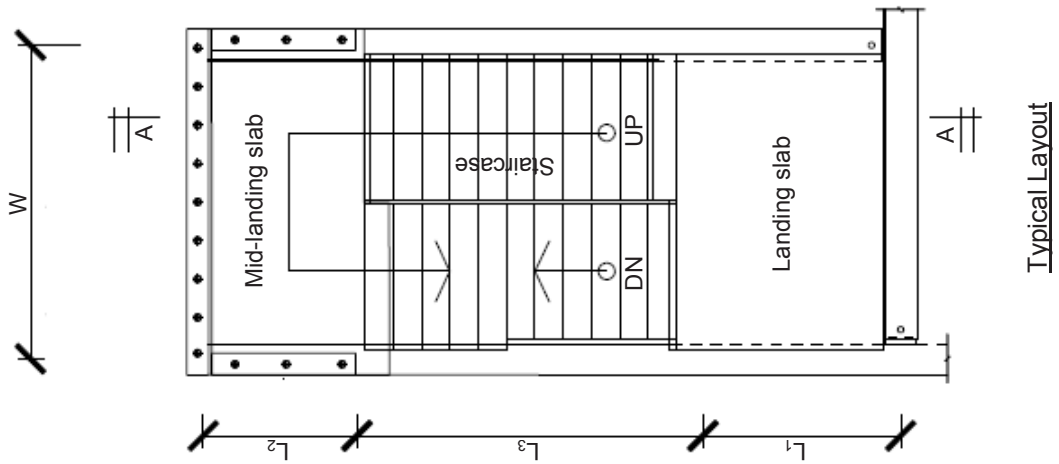

Staircase type schedule

Type	W (mm)	Landing slab, L ₁ (mm)	Mid-landing slab, L ₂ (mm)	Staircase, L ₃ (mm)	Thickness (mm)
SC-150	3000	2000	2000	3000	150
SC-200	3500	2500	2500	3500	200
SC-250	4000	3000	3000	4000	250

Typical Layout

PRECAST STAIRCASE – DETAILS

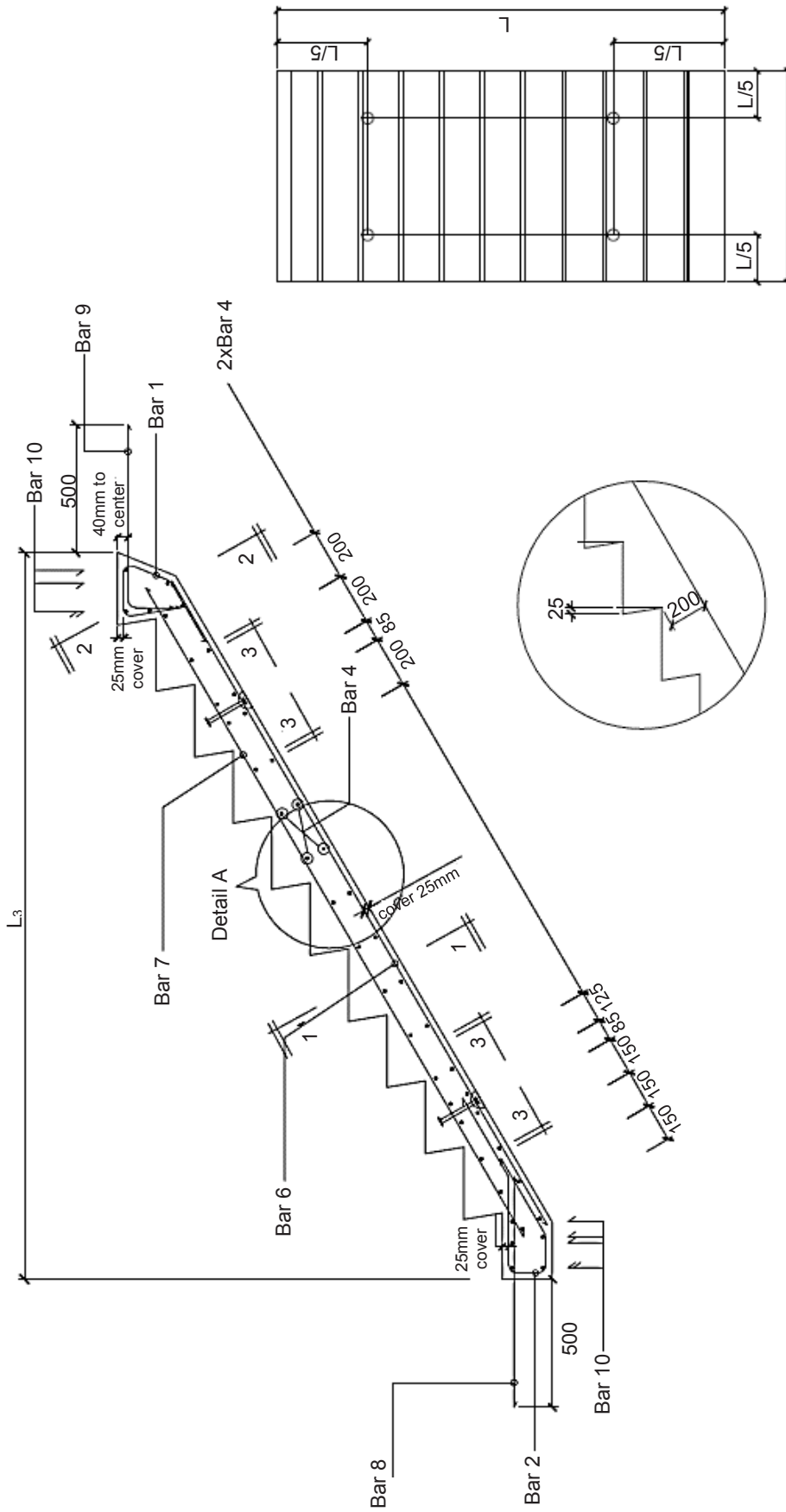

Plan View

Detail A

Staircase Reinforcement
Side elevation

PRECAST STAIRCASE – DETAILS

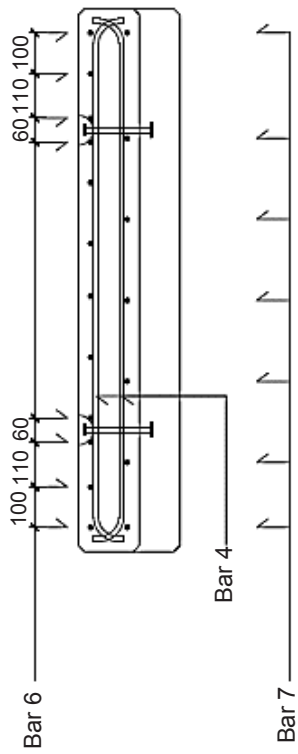

Section 1-1

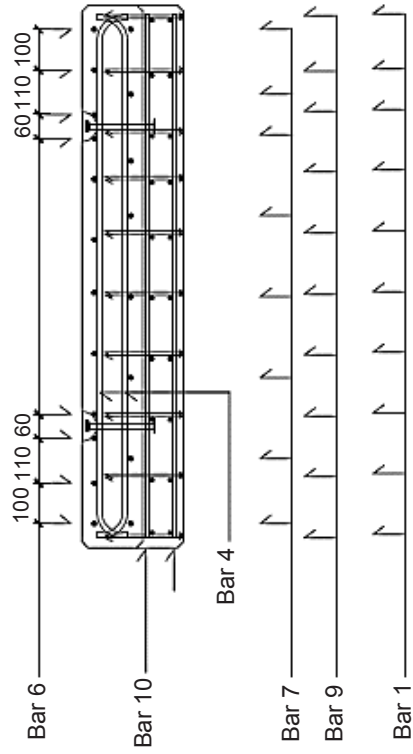

Section 2-2

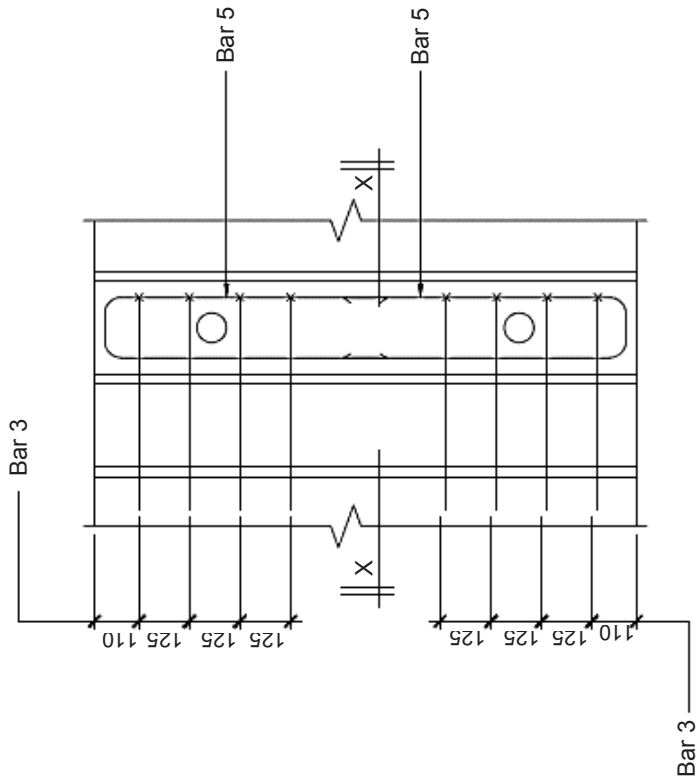

Section 3-3

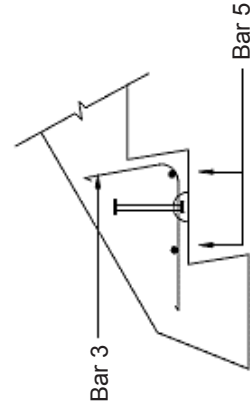

Section X-X

PRECAST STAIRCASE (LANDING SLAB) – DETAILS

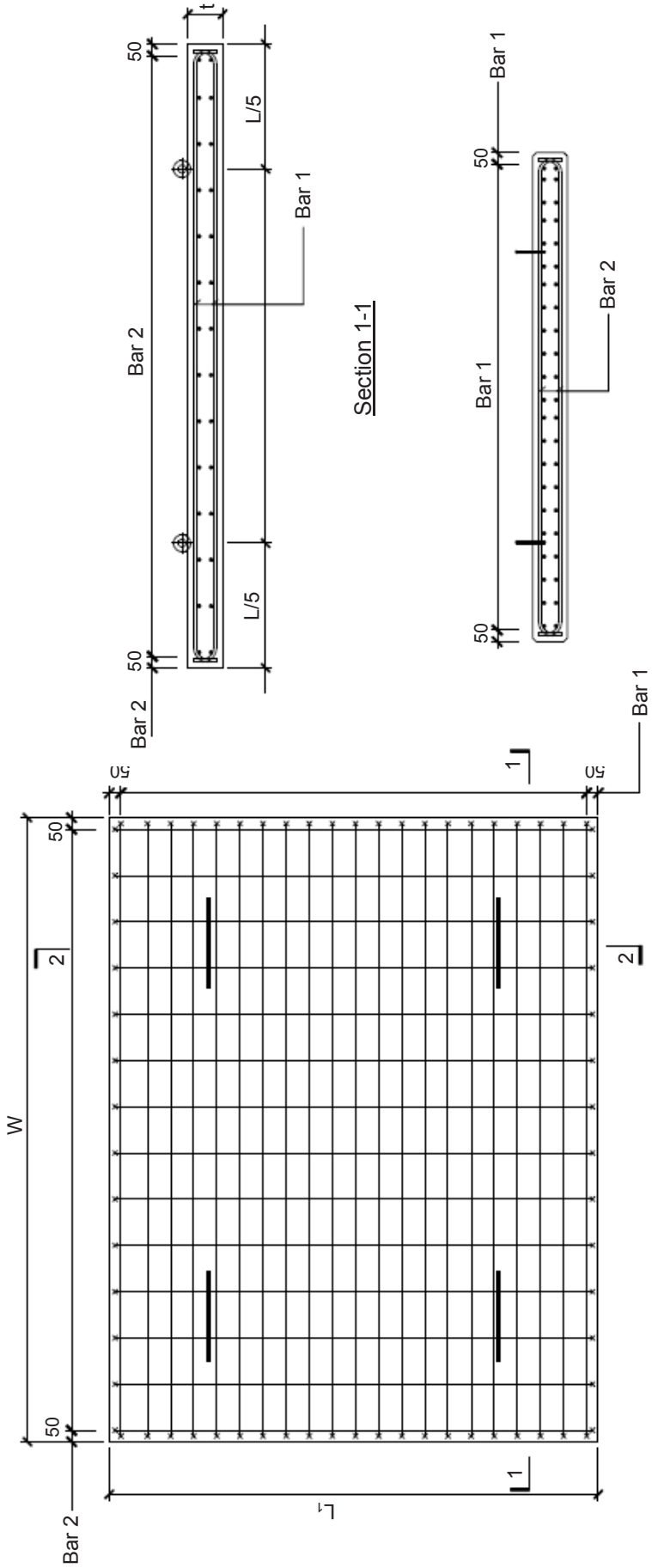

Plan view

Landing slab reinforcement

PRECAST STAIRCASE (MID-LANDING SLAB) – DETAILS

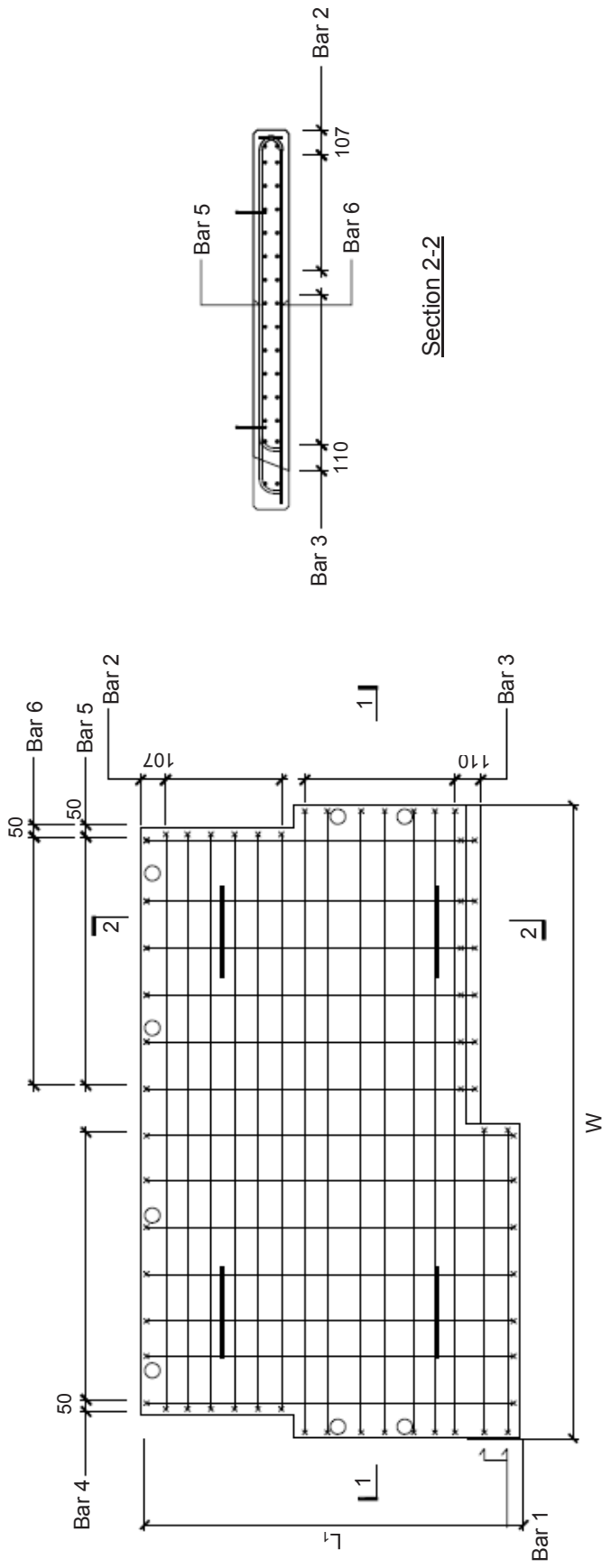

Section 2-2

Plan view

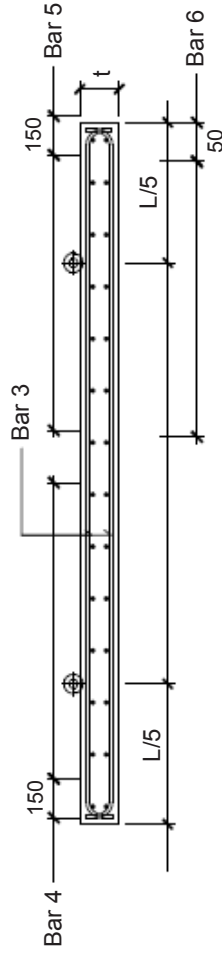

Section 1-1

Mid-landing slab reinforcement

Table 40

Precast staircase

Code of Component	Reinforcement									
	Bar 1	Bar 2	Bar 3	Bar 4	Bar 5	Bar 6	Bar 7	Bar 8	Bar 9	Bar 10
SC-150	R8-150	R8-150	4T16	T12-200	1T16	T12-150	T12-200	T12-150	T12-150	5T12
SC-200	R8-150	R8-150	4T16	T12-200	1T16	T12-100	T12-150	T12-150	T12-150	5T12
SC-250	R8-150	R8-150	4T16	T12-200	1T16	T16-200	T16-250	T12-150	T12-150	5T12

For reinforcement arrangement refer to page 153-page 158

Table 41

Landing slab

Code of Component	Reinforcement	
	Bar 1	Bar 2
SC-150	2T10-150	2T10-250
SC-200	2T12-200	2T10-250
SC-250	2T12-150	2T10-200

For reinforcement arrangement refer to page 153-page 158

Table 42

Mid-landing slab

Code of Component	Reinforcement					
	Bar 1	Bar 2	Bar 3	Bar 4	Bar 5	Bar 6
SC-150	2T10-100	2T10-150	2T10-150	2T10-250	T10-250	T10-250
SC-200	2T10-100	2T12-200	2T12-200	2T10-250	T10-250	T10-250
SC-250	2T10-100	2T12-150	2T12-150	2T10-200	T10-200	T10-200

For reinforcement arrangement refer to page 153-page 158



PRECAST COMPONENT

- A. PRECAST RECTANGULAR BEAM (SIMPLY SUPPORTED)
- B. PRECAST RECTANGULAR BEAM (CONTINUOUS BEAM)
- C. PRECAST INVERTED T BEAM (CONTINUOUS BEAM)
- D. PRECAST EDGE BEAM (CONTINUOUS BEAM)
- E. PRECAST SQUARE COLUMN
- F. PRECAST RECTANGULAR COLUMN
- G. PRECAST HALF SLAB (CONTINUOUS SUPPORTED)
- H. PRECAST HOLLOWCORE SLAB
- I. PRECAST PRESTRESSED PLANK
- J. PRECAST WALL (LOAD BEARING)
- K. PRECAST WALL (NON-LOAD BEARING)
- L. PRECAST STAIRCASE
- M. PRECAST CORBEL CONNECTION**
- N. PRECAST COLUMN NIB CONNECTION
- O. PRECAST HALF JOINT CONNECTION
- P. WET JOINT CONNECTION

PRECAST CORBEL CONNECTION

Specification

- a. Minimum concrete grade C35 (precast and cast in-situ concrete).
- b. Fire resistance = 2 hours.
- c. Characteristic of steel reinforcement
High tensile (T) $f_y = 460 \text{ N/mm}^2$
Mild steel (R) $f_y = 250 \text{ N/mm}^2$
- d. P denotes ultimate point load transmit to the corbel (kN) a, is distance from the face of a column to top P.
- e. Only corbel Type 1 and corbel Type 2 are presented in this catalogue. For other type, shall refer to competent professional personnel.
- f. The design have been prepared in accordance with BS 8110 (1997).
- g. Connection shall be designed to suit the architect and structural requirements and to be checked and approved by competent person.

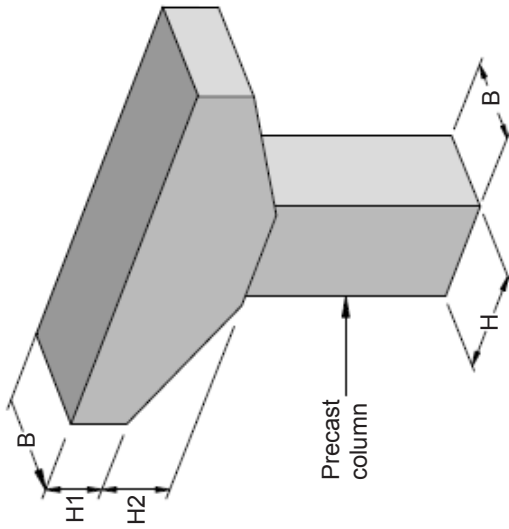

Corbel Type 2-Two Side
3D View

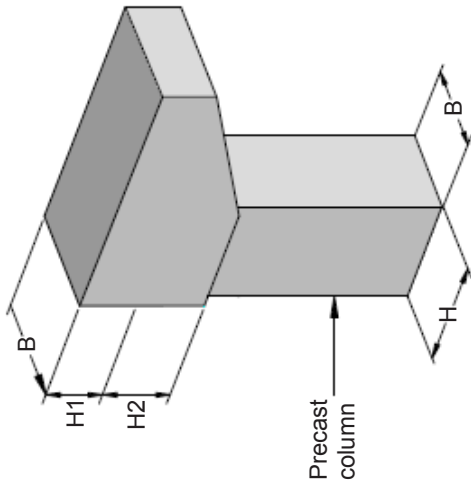

Corbel Type 1-One Side
3D View

Concrete Cover Schedule

Beam Width, B (mm)	Concrete cover to main reinforcement
250	50
250	40
350	35

PRECAST CORBEL CONNECTION - DETAILS

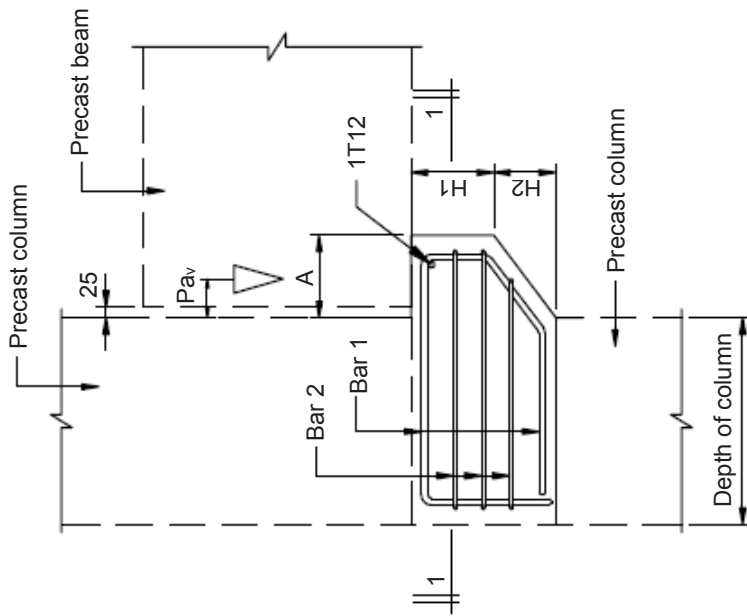

Elevation

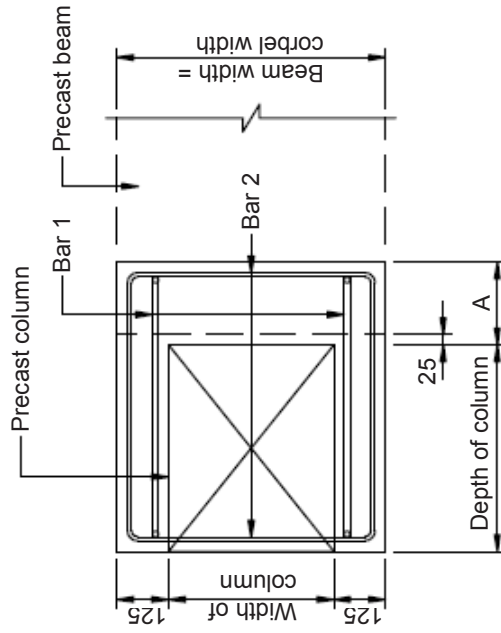

Section 1-1

Corbel Type 1-One Side

PRECAST CORBEL CONNECTION - DETAILS

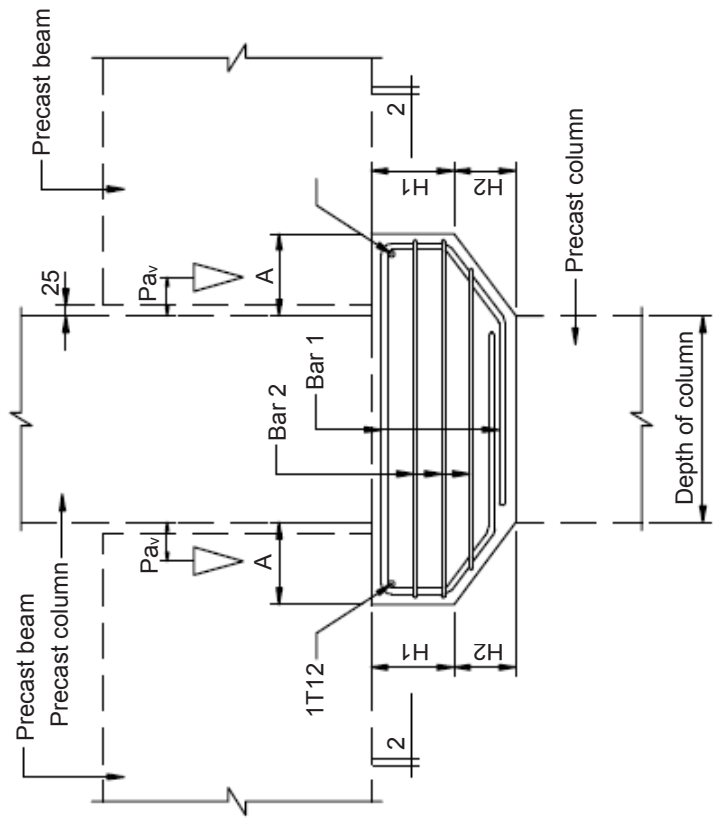

Elevation

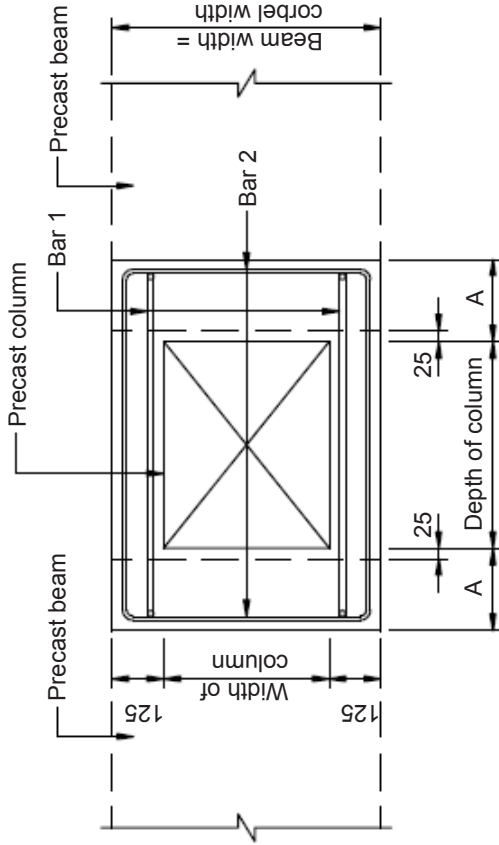

Section 2-2

Corbel Type 2-Two
Side

Table 43

Corbel for beam rectangular

Beam Width for Beam Rectangular B (mm)	A (mm)	H1 (mm)	H2 (mm)	Ultimate Point Load P (kN)	Reinforcement	
					Bar 1	Bar 2
200	200	200	150	250	2T16	3T10
250	200	200	150	380	3T16	3T10
300	200	200	150	155	4T12	3T10
350	200	200	150	208	4T12	3T10
400	200	200	150	260	5T12	3T10

For reinforcement arrangement refer to page 162 – page 164

Table 44

Corbel for inverted T shaped beam and edge beam

Beam Width for Inverted T Beam B (mm)	Beam Width for Edge Beam B (mm)	A (mm)	H1 (mm)	H2 (mm)	Ultimate Point Load P (kN)	Reinforcement	
						Bar 1	Bar 2
500	400	200	200	150	306	6T12	3T10
600	500	200	200	150	367	7T12	3T10
650	550	200	200	150	428	8T12	3T10
700	600	200	200	150	490	8T12	3T10
750	650	200	200	150	551	9T12	3 x 2T10
800	700	200	200	150	612	9T12	3 x 2T10

For reinforcement arrangement refer to page 162 – page 164





PRECAST COMPONENT

- A. PRECAST RECTANGULAR BEAM (SIMPLY SUPPORTED)
- B. PRECAST RECTANGULAR BEAM (CONTINUOUS BEAM)
- C. PRECAST INVERTED T BEAM (CONTINUOUS BEAM)
- D. PRECAST EDGE BEAM (CONTINUOUS BEAM)
- E. PRECAST SQUARE COLUMN
- F. PRECAST RECTANGULAR COLUMN
- G. PRECAST HALF SLAB (CONTINUOUS SUPPORTED)
- H. PRECAST HOLLOWCORE SLAB
- I. PRECAST PRESTRESSED PLANK
- J. PRECAST WALL (LOAD BEARING)
- K. PRECAST WALL (NON-LOAD BEARING)
- L. PRECAST STAIRCASE
- M. PRECAST CORBEL CONNECTION
- N. PRECAST COLUMN NIB CONNECTION**
- O. PRECAST HALF JOINT CONNECTION
- P. WET JOINT CONNECTION

PRECAST COLUMN NIB CONNECTION

Specification

- a. Minimum concrete grade C35 (precast and cast in-situ concrete).
- b. Concrete cover to main reinforcement = 35mm
- c. Fire resistance = 2 hours.
- d. Characteristic of steel reinforcement
High tensile (T) $f_y = 460 \text{ N/mm}^2$
Mild steel (R) $f_{yv} = 250 \text{ N/mm}^2$
- e. The design has been prepared in accordance with BS 8110 (1997).
- f. Connection shall be designed to suit the architect and structural requirements and to be checked and approved by competent person.

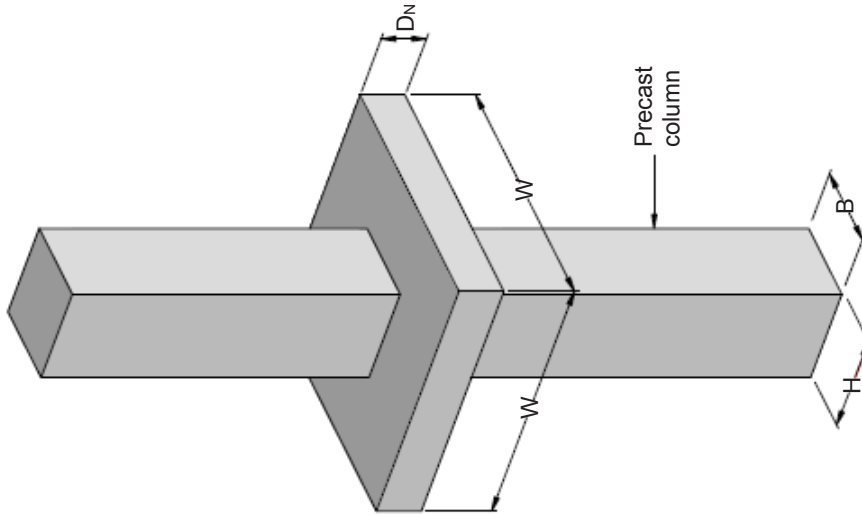

Column Nib
3D View

PRECAST COLUMN NIB CONNECTION - DETAILS

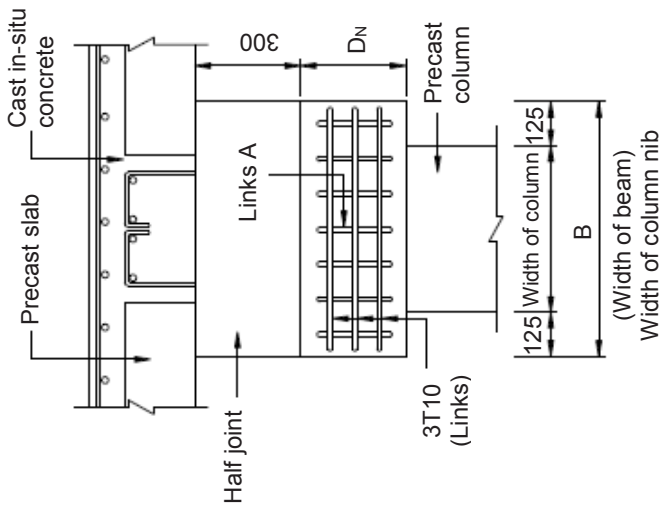

Section X-X
Detail 3b

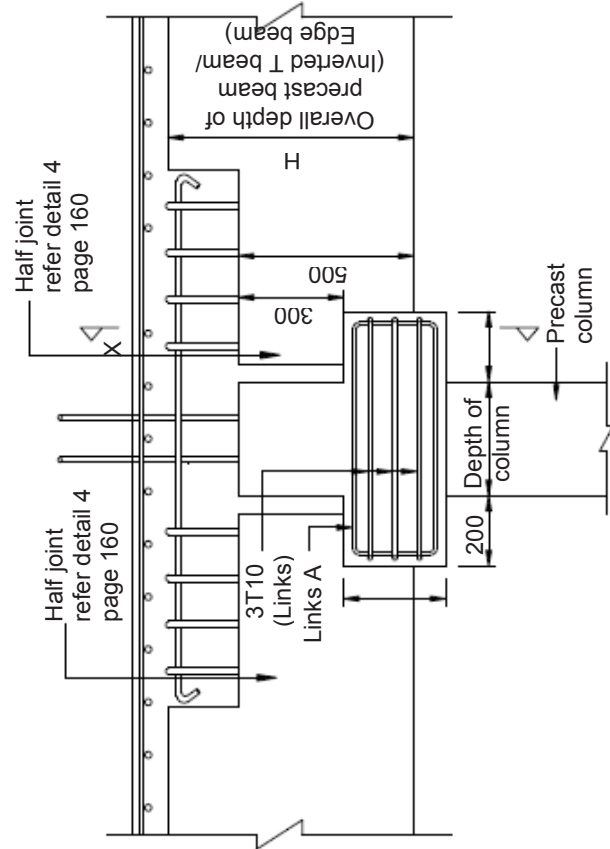

Elevation
Detail 3a

Column Nib Details
Detail 3

Table 45

Refer Table Inverted T Beam / Edge Beam B (mm) x H (mm)	Column Nib Details	
	Thickness D _N (mm)	Width W (mm)
500 x 600	300	500
500 x 700		
600 x 600	300	600
600 x 700		
650 x 600	350	650
650 x 700		
700 x 600	350	700
700 x 700		
750 x 600	400	750
750 x 700		
800 x 600	400	800
800 x 700		
		Links A
		5T16 @ 85 mm c/c
		6T16 @ 85 mm c/c
		6T16 @ 95 mm c/c
		7T16 @ 85 mm c/c
		7T16 @ 95 mm c/c
		7T16 @ 100 mm c/c

For reinforcement arrangement refer to page 168 – page 169

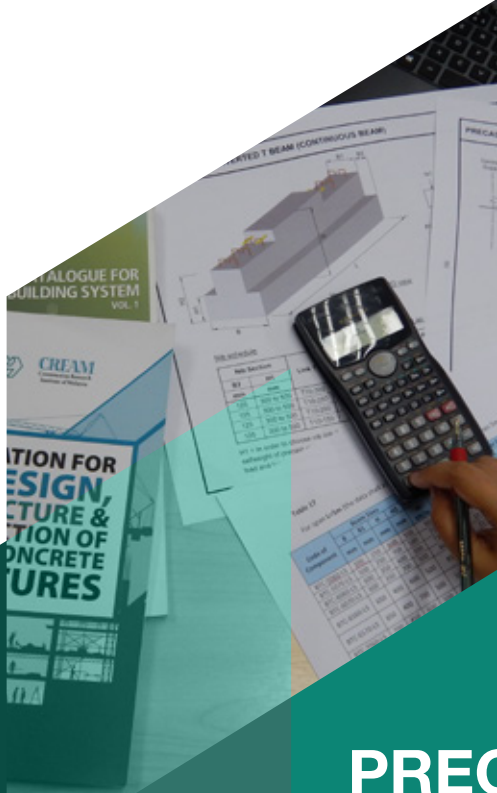

PRECAST COMPONENT

- A. PRECAST RECTANGULAR BEAM (SIMPLY SUPPORTED)
- B. PRECAST RECTANGULAR BEAM (CONTINUOUS BEAM)
- C. PRECAST INVERTED T BEAM (CONTINUOUS BEAM)
- D. PRECAST EDGE BEAM (CONTINUOUS BEAM)
- E. PRECAST SQUARE COLUMN
- F. PRECAST RECTANGULAR COLUMN
- G. PRECAST HALF SLAB (CONTINUOUS SUPPORTED)
- H. PRECAST HOLLOWCORE SLAB
- I. PRECAST PRESTRESSED PLANK
- J. PRECAST WALL (LOAD BEARING)
- K. PRECAST WALL (NON-LOAD BEARING)
- L. PRECAST STAIRCASE
- M. PRECAST CORBEL CONNECTION
- N. PRECAST COLUMN NIB CONNECTION
- O. PRECAST HALF JOINT CONNECTION**
- P. WET JOINT CONNECTION

PRECAST HALF JOINT CONNECTION

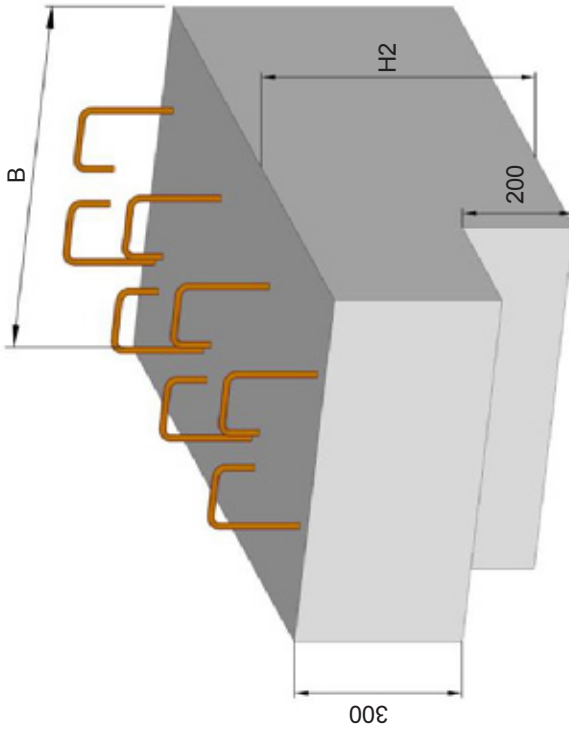

Half Joint Detail
3D View

Lap Schedule

Reinforcement Bar Size (mm)	Lap Length (mm)
12	500
16	650
20	800
25	1000
32	1300

Table 46: Bar A and Links B

B1 (Refer Table Inverted T Beam or Edge Beam)	Bar A	Links B
B1 ≤ 400 mm	3T25	3 x 2T10 @ 50 mm
B1 > 400 mm	5T25	3 x 2T12 @ 50 mm

Specification

- Minimum concrete grade C35 (precast and cast in-situ concrete).
- Concrete cover to main reinforcement = 35mm
- Fire resistance = 2 hours.
- Characteristic of steel reinforcement
High tensile (T) $f_y = 460 \text{ N/mm}^2$
Mild steel (R) $f_{yv} = 250 \text{ N/mm}^2$
- The design has been prepared in accordance with BS 8110 (1997).
- Connection shall be designed to suit the architect and structural requirements and to be checked and approved by competent person.

PRECAST HALF JOINT CONNECTION - DETAILS

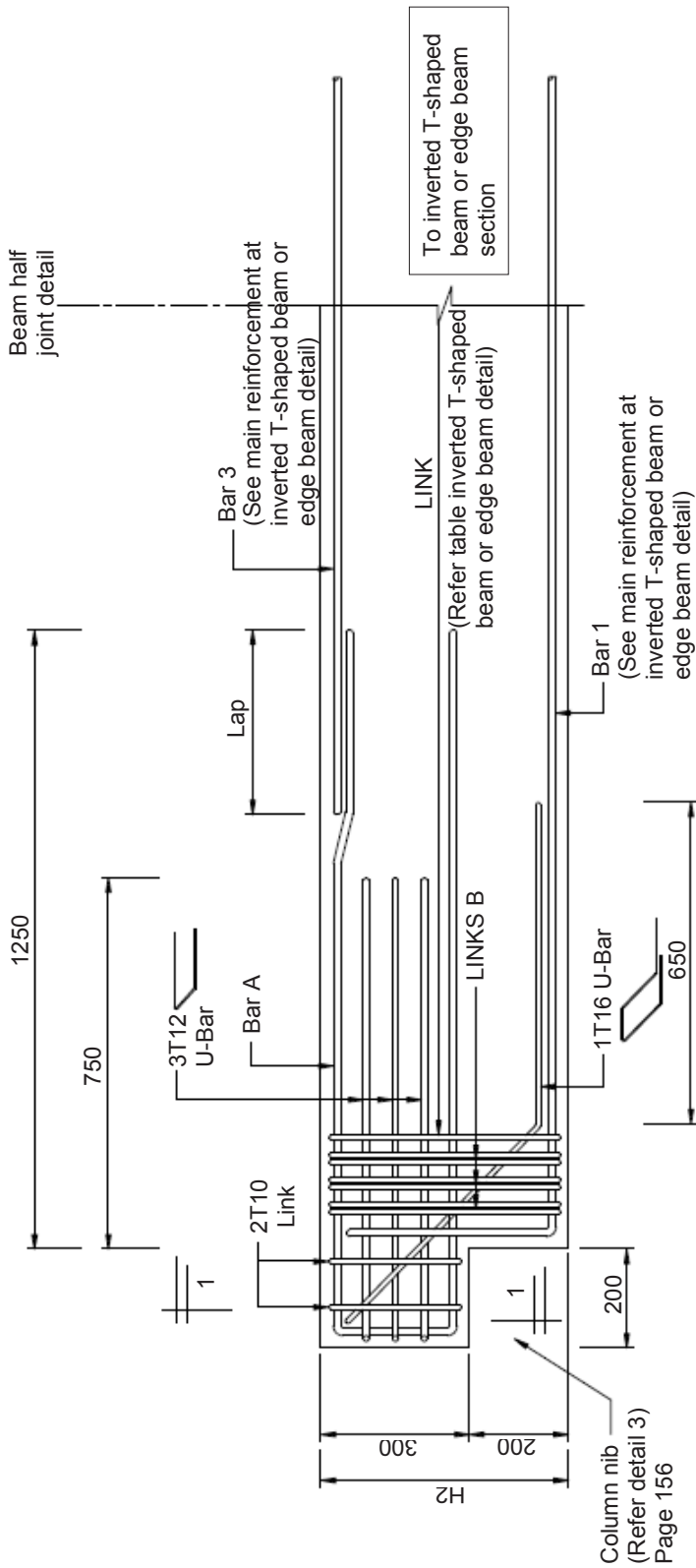

Detail 4
Half Joint Details

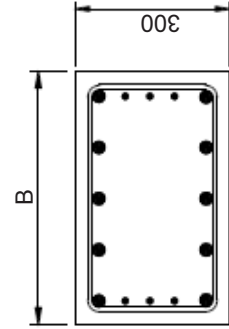
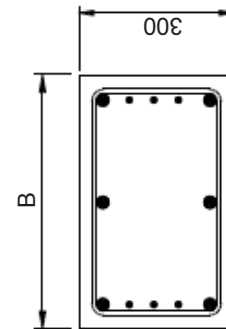





PRECAST COMPONENT

- A. PRECAST RECTANGULAR BEAM (SIMPLY SUPPORTED)
- B. PRECAST RECTANGULAR BEAM (CONTINUOUS BEAM)
- C. PRECAST INVERTED T BEAM (CONTINUOUS BEAM)
- D. PRECAST EDGE BEAM (CONTINUOUS BEAM)
- E. PRECAST SQUARE COLUMN
- F. PRECAST RECTANGULAR COLUMN
- G. PRECAST HALF SLAB (CONTINUOUS SUPPORTED)
- H. PRECAST HOLLOWCORE SLAB
- I. PRECAST PRESTRESSED PLANK
- J. PRECAST WALL (LOAD BEARING)
- K. PRECAST WALL (NON-LOAD BEARING)
- L. PRECAST STAIRCASE
- M. PRECAST CORBEL CONNECTION
- N. PRECAST COLUMN NIB CONNECTION
- O. PRECAST HALF JOINT CONNECTION
- P. WET JOINT CONNECTION**

WET JOINT CONNECTIONS – COLUMN TO COLUMN & COLUMN TO BEAM

Note:

- a. All corrugated pipe size shall refer to manufacturer's detail.
- b. The system of connection shall not be limited to wet joint connection only.
- c. The connection system between precast component and cast-in-situ structure shall be referred to competent person.

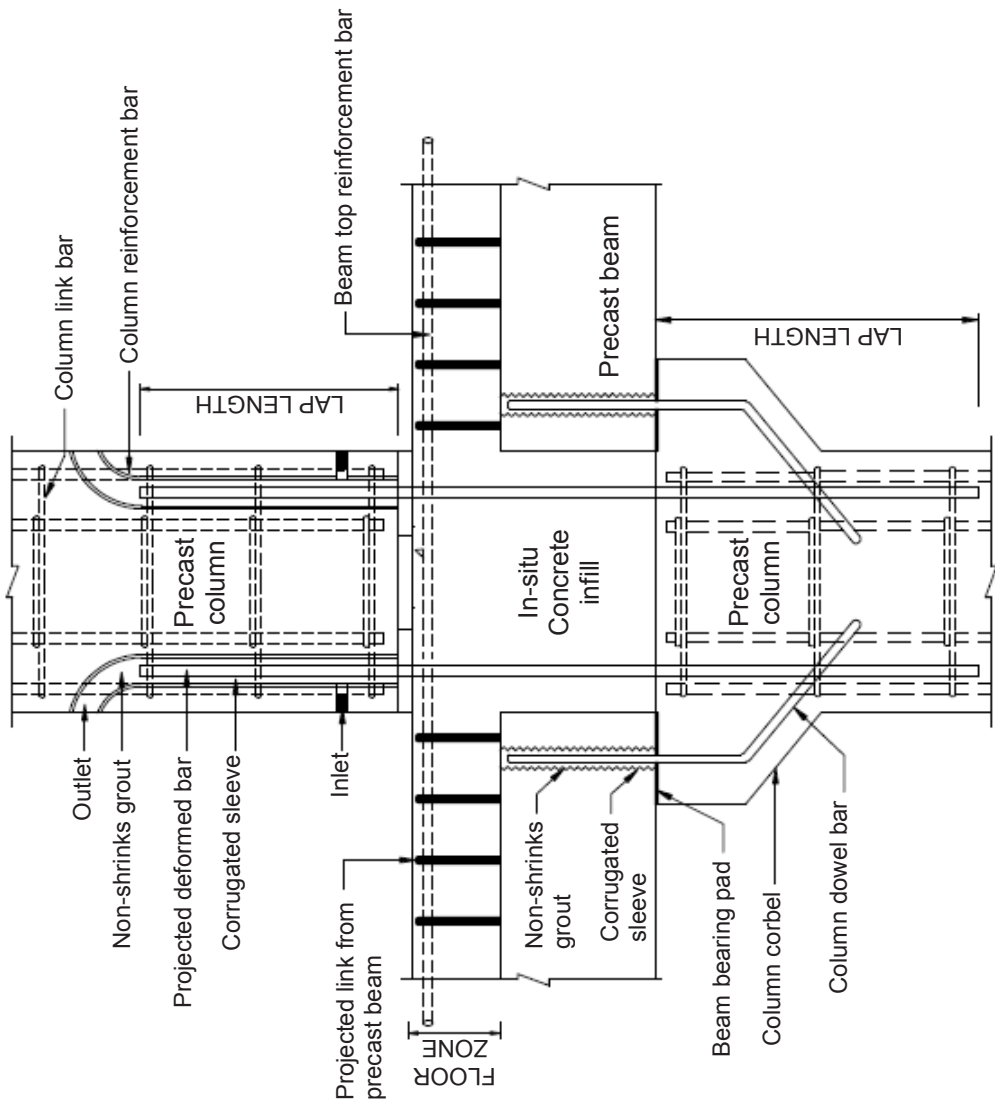

Typical Column Connection 2
(Column to column connection & column to beam connection)

WET JOINT CONNECTIONS – SINGLE TIER COLUMN (COLUMN TO BEAM CONNECTION)

Note:

- a. All corrugated pipe size shall refer to manufacturer's detail.
- b. The system of connection shall not be limited to wet joint connection only.
- c. The connection system between precast component and cast-in-situ structure shall be referred to competent person.

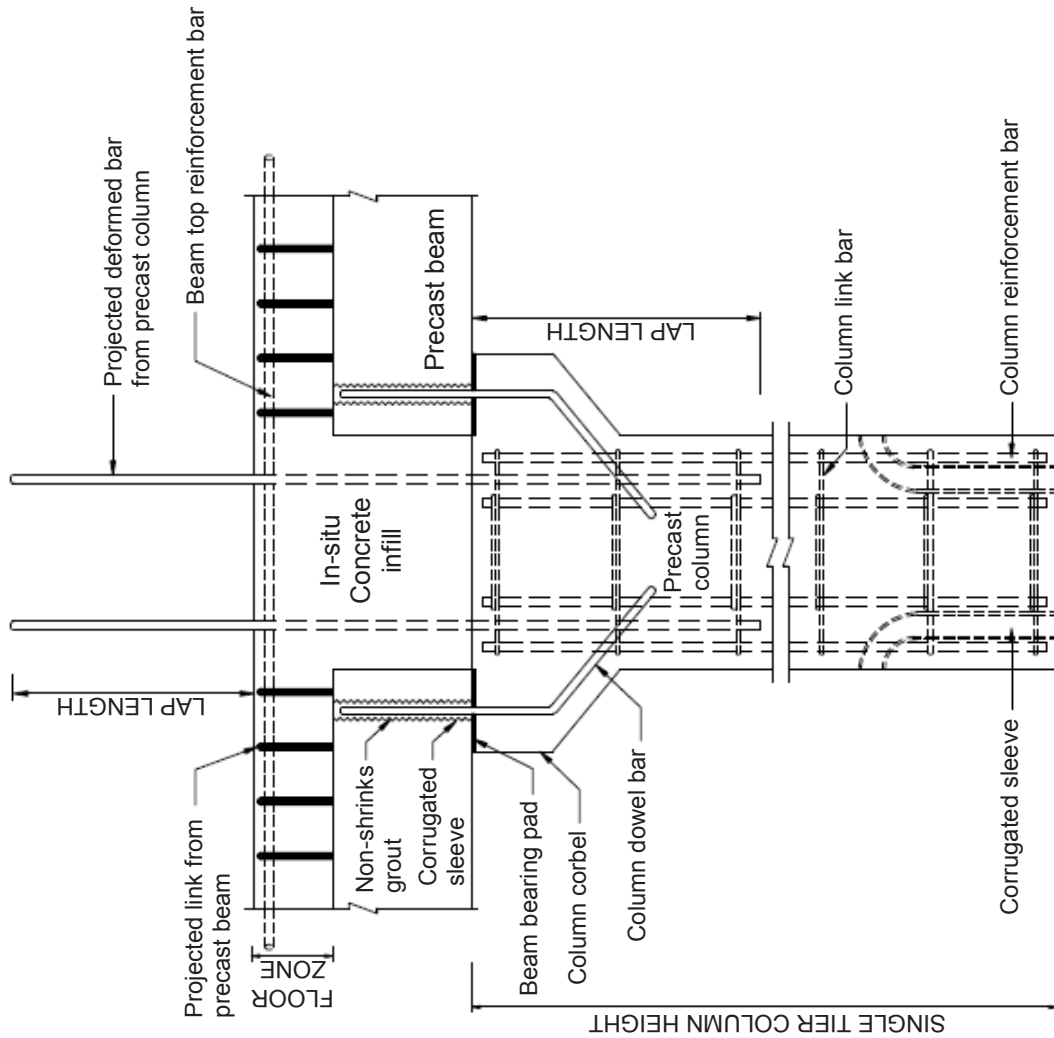

Typical Column Connection 3
Single tier column
(Column to beam connection)

WET JOINT CONNECTIONS—DOUBLE TIER COLUMN (COLUMN-COLUMN & COLUMN-BEAM)

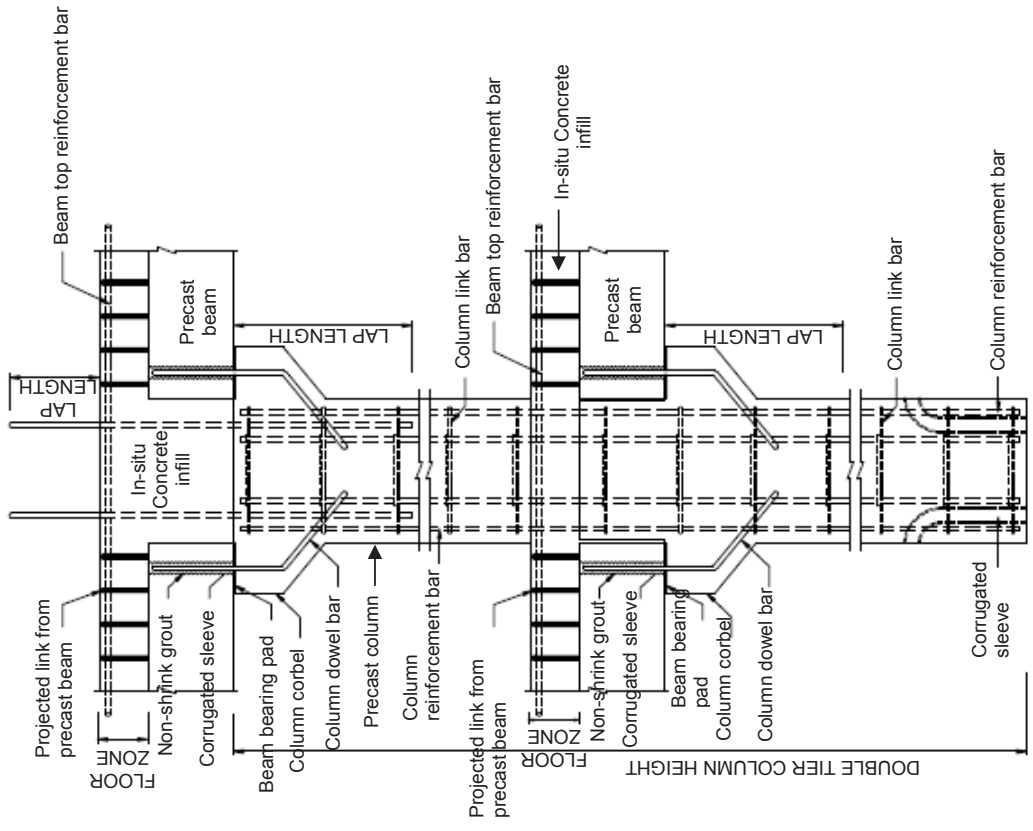

Typical Column Connection 4
 Double tier column
 (Column-column & column-beam connection)

Note:

- a. All corrugated pipe size shall refer to manufacturer's detail.
- b. The system of connection shall not be limited to wet joint connection only.
- c. The connection system between precast component and cast-in-situ structure shall be referred to competent person.

WET JOINT CONNECTIONS – PRECAST BEAM AND PRECAST SLAB CONNECTION

Note:

- a. The minimum sitting of the precast half slab on the precast beam is 20 mm or shall be referred to competent person.
- b. The system of connection shall not be limited to wet joint connection only.
- c. The connection system between precast component and cast-in-situ structure shall be referred to competent person.

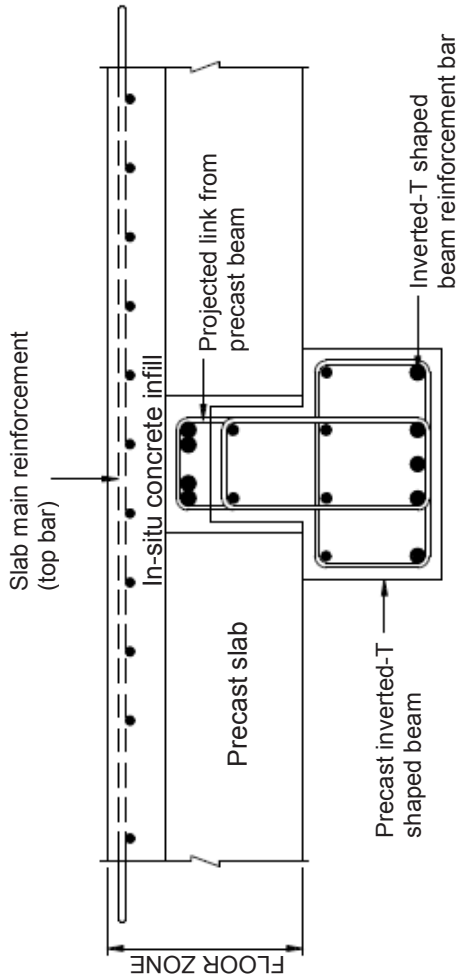

a) Typical Connection of Inverted T Beam and Precast Slab

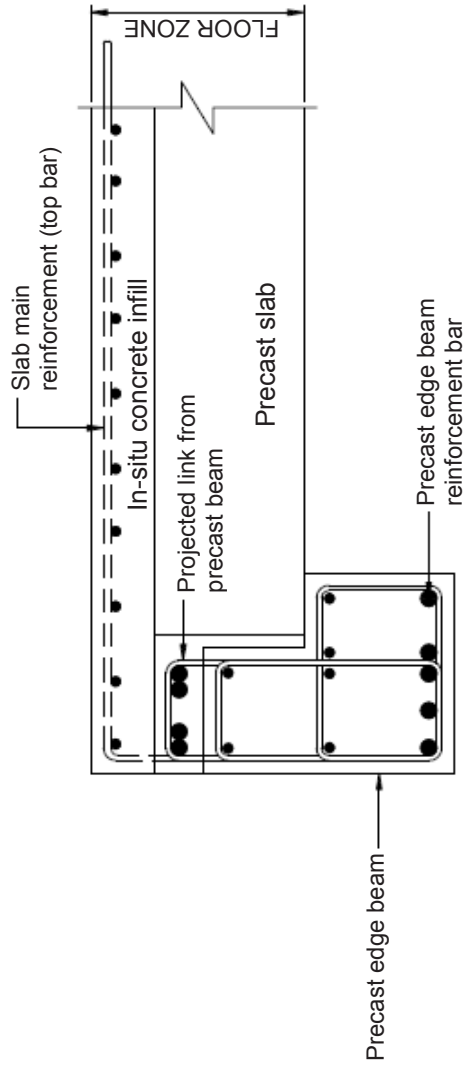

b) Typical Connection of Edge Beam and Precast Slab

WET JOINT CONNECTIONS – SINGLE TIER COLUMN (COLUMN TO BEAM CONNECTION)

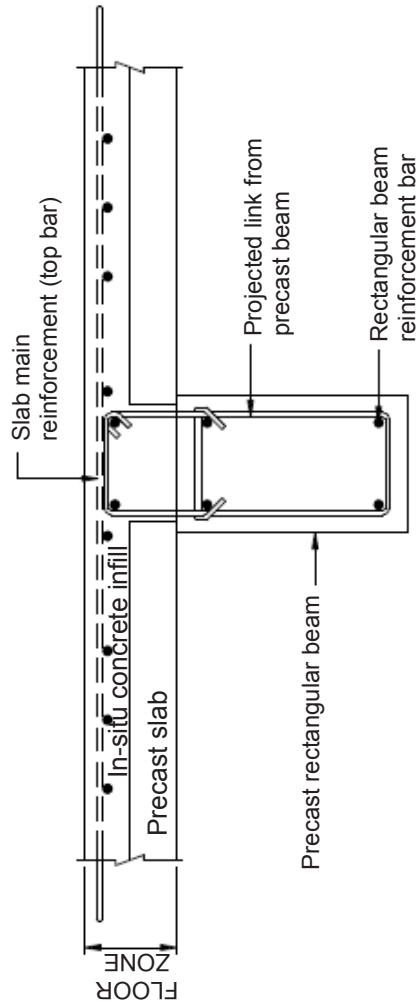

c) Typical Connection of Rectangular Beam and Precast Slab

Note:

- a. The minimum sitting of the precast half slab on the precast beam is 20 mm or shall be referred to competent person.
- b. The system of connection shall not be limited to wet joint connection only.
- c. The connection system between precast component and cast-in-situ structure shall be referred to competent person.

REFERENCES



Table 17
For span L=5m (the data shall a...)

Code of Component	B1	H	H2	mm	mm	mm	kN/m
BTC-5060-L5	500	250	600	500	60	190	60
BTC-5070-L5	500	250	700	500	70	224	70
BTC-6060-L5	600	300	600	500	73	200	73
BTC-6070-L5	600	350	600	500	86	269	86

Table 17
For span L=5m (the data shall a...)

Code of Component	B1	H	H2	mm	mm	mm	kN/m
BTC-5060-L5	500	250	600	500	60	190	60
BTC-5070-L5	500	250	700	500	70	224	70
BTC-6060-L5	600	300	600	500	73	200	73
BTC-6070-L5	600	350	600	500	86	269	86

References

- BS 8110-1: 1997, Structural use of concrete - Code of practice for design and construction, BSI, London.
- CIDB, Malaysia (2005), IBS Digest January - March
- CIDB, Malaysia (2006), IBS International Exhibition
- CIDB, Malaysia (2006), Industrialised Building System in Malaysia
- CIDB, Malaysia (2008), Catalogue of Industrialised Building System (IBS) Components
- CIDB, Malaysia (2009), Katalog IBS Bagi Projek Bangunan IBS SIRI 1- Komponen Struktur Konkrit Pra-Tuang.
- CIDB, Malaysia (2009), Malaysia IBS International Exhibition
- CIDB, Singapore (1999), Structural Precast Concrete Handbook.
- CREAM (2016), Specification for The Design, Manufacturer & Construction of Precast Concrete Structures.
- Donaldson, B (1991), ASTM Committee E-6 on Performance of Building Constructions, Philadelphia.
- Elliott, K. S., (2002), Precast Concrete Structures. Butterworth-Heinemann Publications, Oxford, United Kingdom.
- Elliot, K.S., and Jolly, C.K. (1996 & 2013), Multi Storey Precast Concrete Framed Structures. United Kingdom: Blackwell Science Ltd.
- Fib (2012), Design of Precast Concrete Structures Against Accidental Actions: Guide to Good Practice. Bulletin No. 63, pp.63.
- Malaysian Construction Industry Standard, CIS 11 : 2008, Design Guide on Precast Concrete Frame with Moment Connection.
- Malaysian Construction Industry Standard, CIS 7 : 2006, Quality Assessment System For Building Construction Work .
- Malaysian Construction Industry Standard, CIS 8 : 2007, Design Guide on Precast Concrete Hollow Core Slab.
- Malaysian Construction Industry Standard, CIS 9 : 2008, Guidelines on handling, transportation, stacking and installation of precast concrete component.
- Manufacturer 1 denotes Eastern Pretech (Malaysia) Sdn Bhd.
- Mosley, W.H. & Bungey, J.H. (1990). Reinforced Concrete Design Fourth Edition
- Riley, M. & Cotgrave, A. (2014). Construction Technology 2: Industrial and Commercial Building. Technology & Engineering. Palgrave Macmillan
- Technical Paper - Eastern Pretech (Malaysia) Sdn Bhd

Technical Paper - Hume Concrete Marketing Sdn Bhd.

Technical Paper - Hume IBS Solutions Industrialised Building System.

Technical Paper - MTD-ACPI Engineering Bhd.

Technical Paper - SPC Industries Sdn Bhd

Technical Paper - Teraju Precast Sdn Bhd.

Trikha, D. N., and Ali, A. A. A., (2004). Industrialised Building Systems. University Putra Malaysia Press, Selangor, Malaysia.



CONSTRUCTION INDUSTRY DEVELOPMENT BOARD

Tingkat 10, Menara Dato' Onn,
Putra World Trade Centre (PWTC), No 45,
Jalan Tun Ismail, 50480 Kuala Lumpur



CONSTRUCTION RESEARCH INSTITUTE OF MALAYSIA

Makmal Kerja Raya Malaysia (MKRM),
CIDB Wilayah Persekutuan, 1st Floor, Block E, Lot 8,
Jalan Chan Sow Lin, 55200 Kuala Lumpur



JABATAN KERJA RAYA

Jalan Sultan Salahuddin, 50582 Kuala Lumpur.

ISBN 978-967-0997-09-4



9 789670 997094